

Cutting Attachments

Quick Specs

Typical Applications

Farm and ranch
Metal fabrication
Construction and demolition
Maintenance and repair
DIY/home hobbyist

Oxy-Fuel Process

Cutting

Fuel Gases

Acetylene
Propane
Natural gas
Propylene

Head Angles

75 degrees
90 degrees

Safe performance and easy handling for even the toughest jobs.



Slip-in tip design. No wrench is needed, allowing for quick and easy tip changes.

Silver-brazed nickel-plated torch joints provide strength, leak-resistance and heat protection.

Three-tube construction keeps gases separate in the cutting attachment until mixed at the tip for safety. Mixed gas stays farthest away from the operator.

Center pre-heat valve. Universal option and usage for both left- and right-handed operators.

Flo-Trol™ valve prevents seat burn out due to reverse flow of mixed gases, helping to reduce maintenance costs (SC200 and MC500 Series cutting attachments only).

Ease-on cutting oxygen provides exceptionally smooth application of cutting oxygen, reducing keyholing and slag blowback without sacrificing extremely high cutting capacity.

Triple o-ring seal for easy 360-degree torch head rotation to reduce operator fatigue.



Torch attachments are warranted for five years, parts and labor (except Toughcut™ CC509P — three years).



Electrical Testing Laboratories (ETL) Listed for oxy-fuel torches.



Miller Electric Mfg. LLC
An ITW Welding Company
1635 West Spencer Street
P.O. Box 1079
Appleton, WI 54912-1079 USA

Equipment Sales US and Canada
Phone: 866-931-9730
FAX: 800-637-2315
International Phone: 920-735-4554
International FAX: 920-735-4125

MillerWelds.com



Flo-Trol™ Valve (SC200 and MC500 Series cutting attachments only.)

Flo-Trol is a built-in check valve in the cutting attachment that automatically closes when there is insufficient oxygen pressure. It helps keep the operator safe while preventing the costly repair of mixed gas flowing back and potentially burning out the cutting seat.

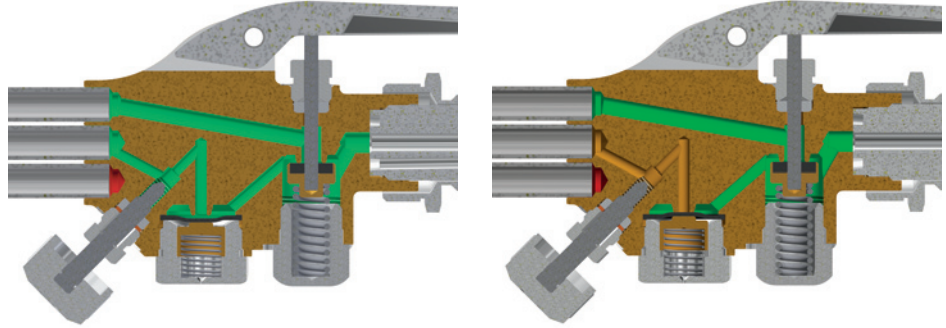

Open Flo-Trol valve. When the oxygen supply pressure is able to overcome the force of the spring, the Flo-Trol valve opens, allowing the free flow of preheat oxygen.

Closed Flo-Trol valve. If there is insufficient oxygen, the oxygen is unable to overcome the force of the Flo-Trol spring, stopping the flow of preheat oxygen or mixed gas travelling back to the system from a starved tip.

SC200 Series Heavy-Duty Cutting Attachments



SC205

SC209

Handles heavy duty cutting requiring high gas flow.

Cuts up to 8-inch (203 mm) thick steel. For use with WH200A heavy-duty torch handle.

Materials of construction

- Handle, lever and butt: nickel-plated brass
- Tubes: nickel-plated stainless steel
- Valve stem: stainless steel
- Valve packing: PTFE
- Flo-Trol™ diaphragm: Buna-N
- Springs: stainless steel
- Silver-brazed assembly
- Stem: stainless steel
- Cutting seat: polyurethane
- Seat retainer: brass
- Gasket: polyester
- Spring retainer: nickel-plated brass
- Backend: nickel-plated brass
- Backend nut: nickel-plated brass
- O-rings: Buna-N

Specifications

- Length: 12.5 in. (318 mm)
- Weight: 1.83 lb. (0.83 kg)
- Head angle: 75° (SC205)
- 90° (SC209)

Gas Service	Torch Handle		Cutting and Gouging Tips		
	Stock No.	Length	Stock No.	Description	Reference
Acetylene	WH200A	7.5 in. (191 mm)	SC12-00 to SC12-5	General cutting tips Extra-long cutting tip Rivet/riser cutting tip Gouging tips	See separate Cutting Tips literature GE/27.0 for detailed cutting capacity, pressure settings and gas consumption
			SC12-4X9		
			SC14-3 SC13-3 and SC13-5		
Propane/natural gas			SC40-0 to SC40-4	General cutting tips Dirty or coated metal cutting tips	
			SC46-2 and SC46-4		
			SC50-0 to SC50-5	Heavy preheat cutting tips	
			SC2-2 and SC2-4	Gouging tips	
Propylene			SC60-0 to SC60-5	Medium preheat cutting tips	

MC500 Series and CC509P Medium-Duty Cutting Attachments



Handles everyday cutting needs.

Cuts up to 6-inch (153 mm) thick steel. For use with WH100 medium-duty torch handle.

Materials of construction

- Handle, lever and butt: nickel-plated brass
- Tubes: nickel-plated cupronickel
- Valve stem: stainless steel
- Valve packing: PTFE
- Flo-Trol™ diaphragm (MC500 Series only): Buna-N
- Springs: stainless steel
- Silver-brazed assembly
- Stem: stainless steel
- Cutting seat: Buna-N
- Seat retainer: brass
- Gasket: polyester
- Spring retainer: nickel-plated brass
- Backend: nickel-plated brass
- Backend nut: nickel-plated brass
- O-rings: Buna-N

Specifications

- Length: 11.25 in. (318 mm)
- Weight: 1.1 lb. (0.5 kg)
- Head angle: 75° (MC505)
90° (MC509)
90° (CC509P)

Medium-Duty Attachment Comparison	Model	Safety Feature	Finish
	MC500 Series	With Flo-Trol™	Buffed and polished, nickel plated
	CC509P (Toughcut™)	Without Flo-Trol™	Nickel plated

Gas Service	Torch Handle		Cutting and Gouging Tips		
	Stock No.	Length	Stock No.	Description	Reference
Acetylene	WH100	7 in. (178 mm)	MC12-00 to MC12-5 MC13-3	General cutting tips Gouging tip	See separate Cutting Tips literature GE/27.0 for detailed cutting capacity, pressure settings and gas consumption
Propane/natural gas			MC40-00 to MC40-4	General cutting tips	

AC309 Standard-Duty Cutting Attachment



Handles light-duty cutting needs.

Cuts up to 3-inch (76 mm) thick steel. For use with AW1A standard-duty torch handle.

Materials of construction

- Handle, lever and butt: nickel-plated brass
- Tubes: nickel-plated cupronickel
- Valve stem: stainless steel
- Valve packing: PTFE
- Springs: stainless steel
- Silver-brazed assembly
- Stem: stainless steel
- Cutting seat: Buna-N
- Seat retainer: brass
- Gasket: polyester
- Spring retainer: nickel-plated brass
- Backend: nickel-plated brass
- Backend nut: nickel-plated brass
- O-rings: Buna-N

Specifications

- Length: 8.5 in. (216 mm)
- Weight: 1 lb. (0.44 kg)
- Head angle: 90°

Gas Service	Torch Handle		Cutting and Gouging Tips		
	Stock No.	Length	Stock No.	Description	Reference
Acetylene	AW1A	5.75 in. (146 mm)	MC12-00 to MC12-4 MC13-3	General cutting tips Gouging tip	See separate Cutting Tips literature GE/27.0 for detailed cutting capacity, pressure settings and gas consumption
Propane/natural gas			MC40-00 to MC40-4	General cutting tips	

Ordering Information

Combination Torch Cutting Attachments	Stock No.	Description	Qty.	Price
SC200 Series Heavy-Duty Cutting Attachments	SC205	75° head angle, Flo-trol™ valve		
	SC209	90° head angle, Flo-trol™ valve		
MC500 Series Medium-Duty Cutting Attachments	MC505	75° head angle, Flo-trol™ valve		
	MC509	90° head angle, Flo-trol™ valve		
Toughcut™ Medium-Duty Cutting Attachment	CC509P	90° head angle		
Standard-Duty Cutting Attachment	AC309	90° head angle		
Combination Torch Handles				
Heavy-Duty Handle	WH200A	For use with SC200 Series cutting attachments		
Medium-Duty Handle	WH100	For use with MC500 Series and CC509P cutting attachments		
Standard-Duty Handle	AW1A	For use with AC309 cutting attachment		
Heavy-Duty Cutting and Gouging Tips (for use with SC200 Series cutting attachments)				
		See page 2		
SC12 Series One-Piece Cutting Tips		For acetylene		
SC40 Series Two-Piece Cutting Tips		For propane or natural gas		
SC46 Series One-Piece Cutting Tips		For propane or natural gas		
SC50 Series Two-Piece Cutting Tips (heavy preheat)		For propane or natural gas		
SC60 Series Two-Piece Cutting Tips (medium preheat)		For propylene		
Extra-Long Cutting Tip	SC12-4X9	For acetylene		
Rivet/Riser Cutting Tip	SC14-3	For acetylene		
SC13 Series Gouging Tips		For acetylene		
SC2 Series Gouging Tips		For propane or natural gas		
Medium-Duty/Standard-Duty Cutting and Gouging Tips (for use with MC500 Series/CC509P/AC309 cutting attachments)				
		See page 3		
MC12 Series One-Piece Cutting Tips		For acetylene		
MC40 Series Two-Piece Cutting Tips		For propane or natural gas		
Gouging Tip		For acetylene		
Replacement Parts				
Cutting Assembly for SC200 Series	SC101	Heavy-duty seat assembly with O-rings, pin, packing, gasket and diaphragm		
O-ring Replacements for SC200 Series (25 per package)	LW15	Heavy-duty O-ring seal for cutting attachments, SW welding tips and ST heating tips		
Torch Head Nut for SC200 Series	G900-41A	Heavy-duty torch head replacement nut		
Cutting Assembly for MC500 Series and CC509P	MC101	Medium-duty seat assembly with O-rings, pin, packing, gasket and diaphragm		
O-ring Replacements for MC500 Series and CC509P (25 per package)	MW15	Medium-duty O-ring seal for cutting attachments, MW welding tips and MT heating tips		
Torch Head Nut for MC500 Series/CC509P/AC309	G690-8	Medium-duty and standard-duty torch head replacement nut		
O-ring Replacements for AC309 (25 per package)	AW15	Standard-duty O-ring seal for cutting attachment, AW welding tips and AT heating tips		
Accessories				
Cylinder Wrench	N230			
Adjustable Circle Cutting Guide	16229	Cuts from 5/8 to 12 in. diameter holes — works with all SC-style cutting tips		

See separate Cutting Tips literature GE/27.0 for detailed cutting capacity, pressure settings and gas consumption.

Date:

Total Quoted Price:

Distributed by:

