

# SuitCase® 12RC

**Wire Feeder with Remote Control** 

## Quick Specs

### Heavy Industrial Applications

Shipbuilding  
Construction  
Heavy manufacturing  
Rental

### Processes

MIG (GMAW)  
Flux-cored (FCAW)  
Pulsed MIG (GMAW-P)

**Input Power** 24 VAC, 10 A

**Net Weight** 31 lb. (14.1 kg)

**Portable wire feeding with standard remote voltage control.**

*Requires control cord — sold separately.*

**Ergonomically sound, lightweight, modular design** is well balanced, and allows improved mobility and ease of carrying to remote welding sites.

**Totally enclosed, impact-resistant, flame-retardant case** provides strength and durability, and protects components and welding wire from moisture, dust and other contaminants.

**Drive roll accessibility** makes it easy to install wire, adjust tension and change drive rolls.



**Built to last in harsh industrial environments**

Plastic case design and double-filtered gas valve ensure SuitCase withstands the harshest industrial environments.



Wire feeder is warrantied for three years, parts and labor.



**Miller Electric Mfg. LLC**  
An ITW Welding Company  
1635 West Spencer Street  
P.O. Box 1079  
Appleton, WI 54912-1079 USA

**Equipment Sales US and Canada**  
Phone: 866-931-9730  
International Phone: 920-735-4554

**MillerWelds.com**



## SuitCase® 12RC Features

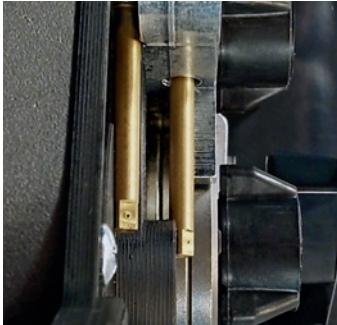
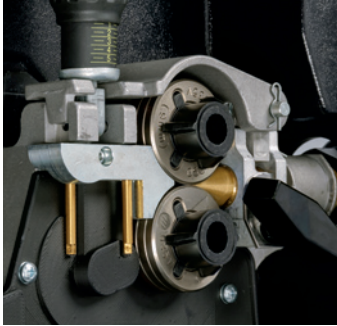

**Ultra-low drag inlet guide pins** make loading the wire easy and do not deform the wire on the way into the drive rolls. Simply thread the wire through the pins and into drive rolls. There are two ways to advance the wire through the drive roll and into the gun. Either open the pressure arm and thread the wire into the grooves in the drive roll and on into the gun inlet **or** place the wire between the pins and use the jog switch to advance the wire through the drive roll.



**Scaled wire pressure knob** provides easy adjustment and consistent pressure on the drive rolls and wire. **Wire drive and motor assembly** is specifically designed for mobile welding applications to provide smooth and consistent wire delivery. Improved motor torque and drive roll system are designed to feed small-diameter solid wire (.023 inch) to large-diameter cored wire (5/64 inch).



**Trigger hold** is located on front panel. Jog and purge are located on inner control panel.

**Digital meters with SunVision™ technology** can display voltage, wire feed speed, and also amperage if desired. Meters can be seen clearly even in direct sunlight.

**Polypropylene case with built-in side rails** and the ability to open the door to change wire with feeder in vertical position.

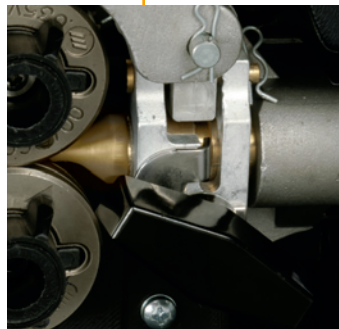

**Gun locking tab** works with guns having corresponding locking grooves to prevent gun from being pulled out if the feeder is dragged by the gun.



**Gas inlet recessed into back of case** is protected from incidental contact by the weld cable, ensuring consistent and contaminant-free shielding gas delivery to the gun. **Double-filtered gas valve** helps keep dirt from clogging and affecting gas flow.

# Specifications (Subject to change without notice.)

**CV DC** (Use with CV, DC power sources.)

Input Power	Welding Power Source Type	Input Welding Circuit Rating	Wire Speed	Wire Type and Diameter Capacity	Max. Spool Size Capacity	Dimensions	Net Weight
24 VAC, 10 A, 50/60 Hz	Constant voltage (CV)	425 A at 60% duty cycle	50–700 ipm (1.3–17.8 m/min.)	<b>Solid wire:</b> .023–.052 in. (0.6–1.4 mm) <b>Flux-cored:</b> .030–5/64 in. (0.8–2.0 mm)	12 in. (305 mm), 45 lb. (20 kg)	H: 15.5 in. (394 mm) W: 9 in. (229 mm) D: 21 in. (533 mm)	31 lb. (14.1 kg)

## Control Panel

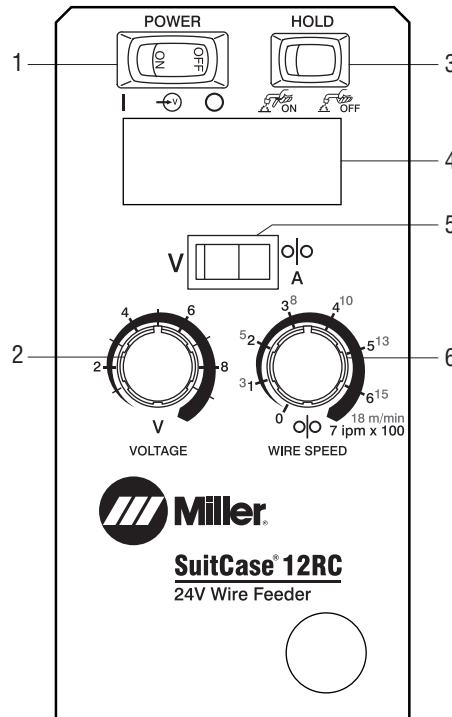





1. Power Control Switch
2. Voltage Control
3. Trigger Hold Switch
4. Meter
5. Voltage/Wire Feed Speed Switch
6. Wire Speed Control

*Note: Jog and purge switches are located on inner control panel.*

## Drive Rolls (Two required.)

Select drive rolls from chart below according to type and wire size being used. Wire inlet guide comes installed on this wire feeder.

Wire Size	"V" groove for hard wire 	"U" groove for soft wire or soft-shelled cored wires 	"V" knurled for hard-shelled cored wires 	"U" clogged for extremely soft wire or soft-shelled cored wires (i.e., hard facing types) 
.023/.025 in. (0.6 mm)	087130	—	—	—
.030 in. (0.8 mm)	053695	—	—	—
.035 in. (0.9 mm)	053700	072000	132958	—
.040 in. (1.0 mm)	053696	—	—	—
.045 in. (1.1/1.2 mm)	053697	053701	132957	083489
.052 in. (1.3/1.4 mm)	053698	053702	132956	083490
1/16 in. (1.6 mm)	053699	053706	132955	053708
.068/.072 in. (1.8 mm)	—	—	132959	—
5/64 in. (2.0 mm)	—	053704	132960	053710

# Ordering Information

Equipment and Options	Stock No.	Description	Qty.	Price
<b>SuitCase® 12RC</b> MIG/FCAW Feeder with Tweco-style Connectors	<b>951580001</b>	With drive rolls and Bernard BTB Gun 300 A with AccuLock™ consumables		
	<b>951599001</b>	With trigger hold, lift eye, drive rolls and Bernard BTB Gun 300 A with AccuLock™ consumables — preflow, postflow and burnback values are set with DIP switches		
	<b>301121</b>	Feeder only		
Flowmeter Kit	<b>300343</b>			
Inline Filter	<b>195189</b>			
Spool Adapter	<b>047141</b>	For 14 lb. spools		
International Gun Adapter	<b>164902</b>	Adapter is required to connect SuitCase to a Euro-style gun		
<b>Accessories</b>				
Control Cords (One required.)	<b>242208025</b>	25 ft. (7.6 m)		
	<b>242208050</b>	50 ft. (15.2 m)		
	<b>242208080</b>	80 ft. (24.3 m)		
Lift Eye	<b>300583</b>	Used for suspending feeder over work area		
<b>Guns</b>				
Bernard® BTB Gun 300 A (GMAW)		See Bernard literature SP-BTB		
Bernard® Dura-Flux™ (FCAW)		See Bernard literature SP-DF		
<b>Power Sources</b>				
XMT® 350 Series and 450 Series		See literature DC/18.93 and DC/18.94		
XMT® 650 Series		See literature DC/18.98		
Big Blue® 400 Pro and 400 PipePro®		See literature ED/5.7 and ED/5.8		
Big Blue® 500 Pro		See literature ED/11.0		
Big Blue® 600 Series		See literature ED/11.5		
Big Blue® 800 Series		See literature ED/14.0		
Trailblazer® Series		See literature ED/4.76, ED/4.79 and ED/4.86		
<b>Consumables</b>				
Drive Rolls				
Wire				

Date:

Total Quoted Price:

Distributed by:

