

# Big Blue® 400 Pro

Issued Oct. 2025 • Index No. ED/5.7

Diesel Engine-Driven  
Welder



## Quick Specs



### Heavy Industrial Applications

Mechanical contractors  
Structural steelwork  
Fabrication  
Maintenance  
Repair  
Rental  
Construction  
Pipe welding

### Processes

Stick (SMAW)  
MIG (GMAW)\*  
Flux-cored (FCAW)\*  
RMD®\*\*  
Pulsed MIG (GMAW-P)\*\*  
DC TIG (GTAW)  
Air carbon arc (CAC-A)  
Rated: 3/16-inch (4.8 mm) carbons  
Capable: 1/4-inch (6.4 mm) carbons  
Air plasma cutting and gouging  
with optional Spectrum® models

### Output Range

DC stick	20–400 A
MIG/flux-cored	14–40 V
DC TIG	20–400 A

### Auxiliary Output Rated at 104°F (40°C)

12,000 watts peak, 10,000 watts continuous

\*With wire feeder.

\*\*ArcReach models only with ArcReach Smart Feeder.

## The professional welder's choice —

designed with the professional in mind, the Big Blue 400 Pro is the best for ease of use, reliability and fuel economy.

### Heavy-duty low-speed T4F and T4i industrial diesel engines

designed to operate over 10,000 hours before the first basic overhaul. Backed by worldwide support and service.



Kubota V1505 four-cylinder diesel.



Mitsubishi S4L2 four-cylinder diesel.



Optimized arc control for stick welding applications. See page 2.



Parameter control at the wire feeder or pendant without needing a control cord. See page 2.



USA model shown is



## WIRELESS INTERFACE CONTROL



Full control of your machine in the palm of your hand. See page 3.



Durable and built to last in harsh industrial environments.



Superior arc performance.



International models available.



Engine-driven welder is warranted for three years, parts and labor.  
Engine is warranted separately by the engine manufacturer.



**Miller Electric Mfg. LLC**  
An ITW Welding Company  
1635 West Spencer Street  
P.O. Box 1079  
Appleton, WI 54912-1079 USA

**Equipment Sales US and Canada**  
Phone: 866-931-9730  
International Phone: 920-735-4554

**MillerWelds.com**  
f X YouTube Instagram LinkedIn



# Big Blue® 400 Pro Features and Controls

**Digital meters** with SunVision™ technology enable welding parameters to be viewed with greater clarity than analog meters — at virtually any angle. Meters can be seen clearly even in direct sunlight.

### Meters display

- Process settings for quick and easy setup
- Preset and actual amperage

### Simple-to-set controls

require no elaborate procedure — just select process and weld.

### 10,000 watts of pure auxiliary power.

Plug in an extra Miller® inverter-based power source for a second welding arc.

### Industrial USB port.

Quickly upload the latest software and download machine log files.



**56.7°C  
RATED**

Miller engine drives are tested to perform in high-temperature climates, even at the highest recorded temperature on earth — 56.7°C\*. They are designed to excel in extreme heat by optimizing engine cooling, reducing harmful environmental effects.

*\*According to the World Meteorological Organization Global Weather & Climate Extremes Archive (<https://wmo.asu.edu/content/world-highest-temperature>)*

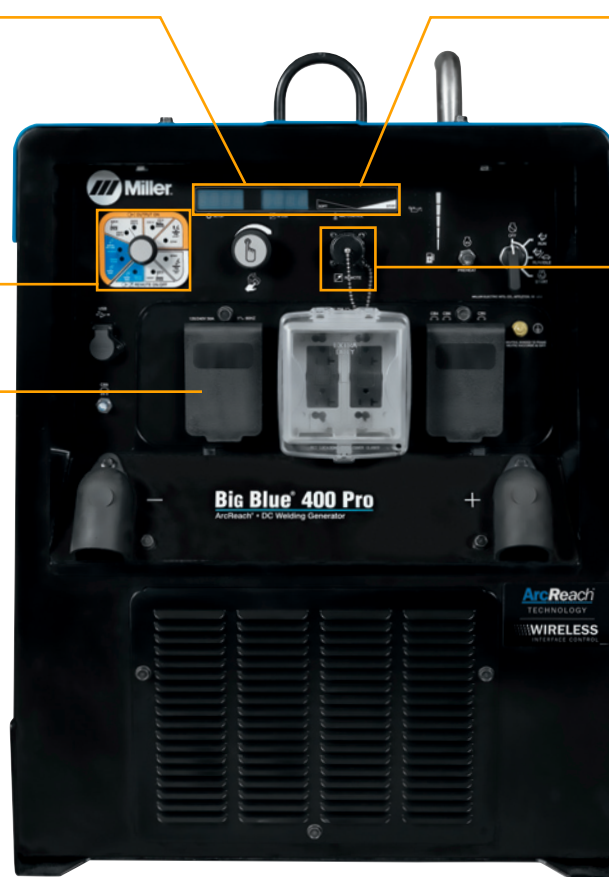

USA model shown



**Arc control** is beneficial when welding with stick and solid wires for easier fine-tuning of tough-to-weld materials and out-of-position applications.

**Standard 14-pin receptacle with Auto-Remote Sense™** for simple connection of remote controls and wire feeders.

**Thermal overload protection** prevents machine damage if the duty cycle is exceeded or airflow is blocked.

**Low OCV stick (VRD)**, when enabled, reduces the open-circuit voltage to 30 volts when the welding power source is not in use, increasing operator safety without compromising arc starts.

**HD powder coat** with zinc-rich primer protects sheet metal from rust and corrosion.

**Standard features include** adjustable Hot Start™, output contactor control, automatic idle, 120-volt block heater and Dynamic DIG™.

# Big Blue® 400 Pro Technologies

## Dynamic DIG™ technology



**Ultra-adaptive arc control.** Unlike conventional DIG that provides a preset amount of short-clearing current, Miller-exclusive Dynamic DIG technology works on a time-based algorithm to optimize metal

deposition. Dynamic DIG provides independent control of the fluidity of the weld puddle (arc control) and the drive of the arc (DIG range). This delivers a tailorable and user-friendly arc to match the application, material, fit-up and welder technique.

## ArcReach® technology (option)

**ArcReach** Parameter control at the wire feeder or pendant without needing a control cord.

An ArcReach system allows you to change weld settings from your ArcReach feeder or stick/TIG remote, saving a trip to the power supply. ArcReach technology uses the existing weld cable to communicate welding control information between the feeder or stick/TIG remote and the power source. This technology eliminates the need for control cords, and their associated problems and costs.

ArcReach-equipped power sources work with non-ArcReach accessories; however the ArcReach benefit is only realized with the complete ArcReach system. This includes an ArcReach-equipped machine and one or more of the following accessories:

- ArcReach SuitCase feeder
- ArcReach Smart Feeder
- ArcReach Stick/TIG Remote

See pages 6 and 7 for more information.

# Big Blue® 400 Pro Technologies

## Wireless interface control (option)

### WIRELESS INTERFACE CONTROL

Work hassle-free with full engine-driven welder control in the palm of your hand.

With wireless interface control, you can remotely switch between welding processes, adjust parameters, select and save preset programs, turn the machine on/off, get service reminders and more from wherever you are on the jobsite — for a more productive day.

Maximize fuel savings and reduce unnecessary engine hours when you use wireless interface control to instantly turn your machine off when needed.

Extend time between fill ups and maintenance intervals while eliminating the need to go back to your machine or climb into the truck to make adjustments.

Wireless interface control is a factory-installed option available on the Big Blue 400 Pro.

### VIEW STATUS

View engine status, fuel level, and battery charge level of remote.

### SELECT PROCESSES

View and select between all available processes.

### CONTACTOR ON/OFF

Turn contactor on/off manually in remote welding mode.

### ENGINE ON/OFF

Turn engine on/off with remote.



### CUSTOM PROGRAMS

Save custom presets in up to four programs and easily switch between pre-programmed settings.

### FINE-TUNE ARC

Quickly adjust and save arc control settings including DIG, DIG range inductance and Auto-Stop™.

### AMP/VOLT ADJUST

Adjust amperage or voltage, by increments or percentage, while welding.

## Big Blue® 400 Pro Benefits

### Easily update technology



With the industrial USB port, you can easily upload the latest software and download machine log files to retrieve in-depth information from your machine such as diagnostics and statistics.

Visit [MillerWelds.com/support](http://MillerWelds.com/support) to download the latest software updates.

### Less noise



Quieter jobsites are more productive because work crews can communicate easier. The Big Blue 400 Pro is only 71.6 decibels (96 Lwa) under a full load, allowing for

easier jobsite communication. Optional wireless interface control makes it easier to shut off your machine when it's not in use, so you can lower jobsite noise levels and hear what's going on around you.

### Jobsite safety



Reduce the need to walk back to or climb into the truck bed to make process and parameter changes, or turn your machine on/off. ArcReach® technology provides

parameter control at the wire feeder or stick/TIG remote and optional wireless interface control provides full front panel control in the palm of your hand, so you can lower the risk of encountering potential jobsite hazards.

### Trailer package (option)

Package consists of the Big Blue® 400 Pro engine drive and HWY-mid frame trailer pre-assembled at the factory, eliminating the need for assembly by end users. Also includes Tweco®-style connectors and 2-in-1 document/fire extinguisher holder. See page 8.



# Specifications (Subject to change without notice.)



Weld Mode/ Process	Weld Output Range	Weld Output Rated at 100% Duty Cycle at 104°F (40°C)	Max. Open-Circuit Voltage	Auxiliary Power Output Rated at 104°F (40°C)**	Sound Levels at Rated Output, 23 ft. (7 m)	Dimensions	Net Weight (without fuel)***
CC/DC (TIG)	20–400 A	300 A at 32 VDC 350 A at 27 VDC 400 A at 24 VDC	85 VDC 30 VDC*	12,000 watts peak 10,000 watts continuous 1-phase, 84/42 A, 120/240 VAC, 60 Hz	<b>Mitsubishi</b> Idle: 68.7 dB (93 Lwa) Weld: 72.1 dB (97 Lwa) <b>Kubota</b> Idle: 66 dB (91 Lwa) Weld: 71.6 dB (96 Lwa)	H: 32 in. (813 mm) W: 26.25 in. (667 mm) D: 56 in. (1,422 mm)	<b>Mitsubishi</b> 993 lb. (450 kg) <b>Kubota</b> 950 lb. (431 kg)
CC/DC (Stick)	20–400 A						
CV/DC (FCAW/MIG)	14–40 V						

\*Sense voltage for Lift-Arc™ TIG and stick with VRD on. \*\*Will operate either 60 Hz or 50/60 Hz power tools, lights, etc. \*\*\*Additional 82 lb. (37 kg) when fuel tank is full.

Certified by Canadian Standards Association to both the Canadian and U.S. Standards. Meets NEMA and IEC output ratings.

## Engine Specifications (Engines warranted separately by the engine manufacturer.)

Engine Brand	Features	HP	Type	Engine Speeds	Capacities	Automatic Engine Shutdown
Mitsubishi S4L2	EPA Tier 4 Final compliant, includes 120 V block heater	24.7	Four-cylinder, liquid-cooled industrial diesel	Idle: 1,500 rpm Weld: 1,800 rpm	Fuel: 11.5 gal. (43.5 L) Oil: 6 qt. (5.7 L) Coolant: 6 qt. (5.7 L)	Low oil pressure, high coolant temperature, low fuel level
Kubota V1505		20.2	Four-cylinder, liquid-cooled industrial diesel			

## Performance Data

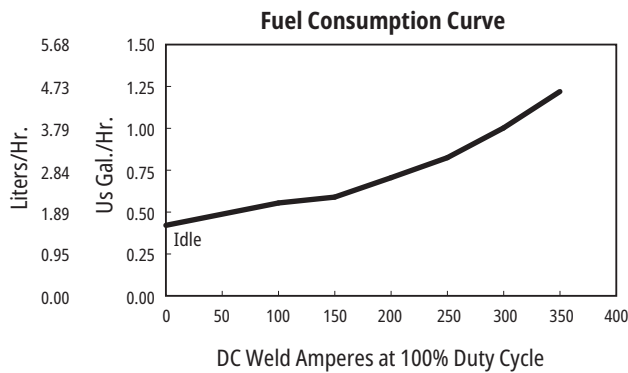

### Simultaneous Welding and Power

Weld Amperes	Total Aux. Power Available (Watts)
25 A	10,000
75 A	10,000
125 A	10,000
175 A	9,000
225 A	7,500
300 A	4,500
350 A	1,000

# Function Guide

1. **Self-calibrating digital weld meters with fault code indication** display preset or actual weld parameters.
2. **Pushbutton main control knob** used for adjusting amperage/voltage, adjusting arc control, and accessing the service menu.
3. **LED process indicator.** Front panel process selections are illuminated with an LED that identifies the active process. This enables the selected weld process to be seen at a distance from the power source.

## 4. Lift-Arc™ TIG with Auto-Stop™ and Auto-Crater™

5. **USB port** allows software updates from a USB drive. A summary file of recorded data from the unit will be saved to a USB drive that is inserted.
6. **Weatherproof Lexan® nameplate** is super durable and resists cracking and fading.
7. **Adjustable fine arc settings** adjusts arc control when in stick processes or inductance when in CV/wire processes to change the weld puddle fluidity. In TIG, Auto-Stop adjusts the arc length at which the arc will terminate. The fine settings assist the operator to get a more tailored arc for their application.
8. **Maintenance interval reminder.** Yellow and red indicator lights let an operator know when the machine is approaching and finally in need of routine maintenance.
9. **Fuel indicator gauge.** Low fuel shutdown shuts engine off prior to running out of fuel to prevent loss of fuel in the system, and make restarts easy.
10. **Glow plugs** assist in cold weather starting.
11. **Engine control switch** is used to start the engine and then select between auto idle and high speed lock.

12. **Standard 14-pin receptacle** for simple connection of remote controls and wire feeders. Includes **Auto Remote Sense™** which automatically switches from panel to remote amperage/voltage (A/V) control with remote connected. Eliminates confusion of a panel/remote switch.

13. **50 A, 120/240 V receptacle and 20 A, 120 V GFCI receptacles with circuit breakers**  
*Note: For matching 240 V plug, order 119172.*

## 14. Weld output terminals

15. **International receptacle panel with 16 A, 240 V receptacle, 20 A 120 V GFCI receptacle and 32 A, 240 V receptacle with circuit breakers**

*Note: For matching 240 V, 16 A plug, order 255416 and for matching 240 V, 32 A plug, order 255418.*

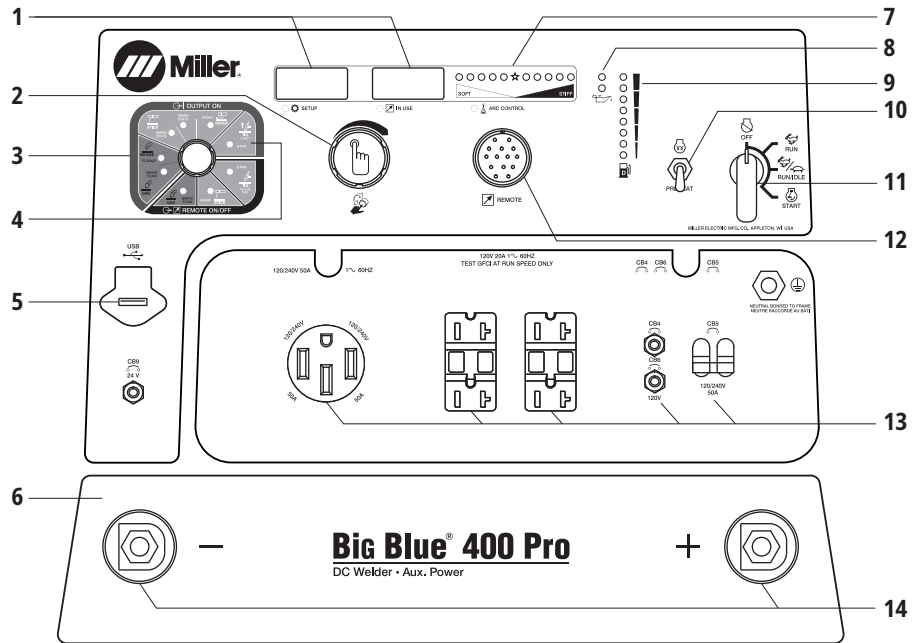

USA model

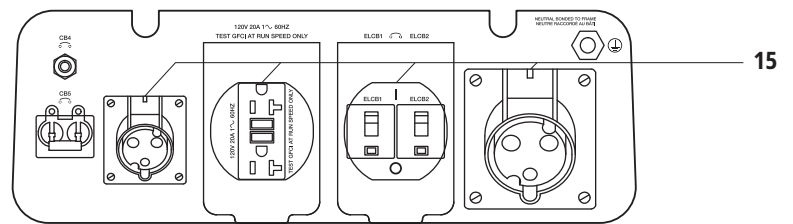

International model receptacles

## ARC START with Lift-Arc™

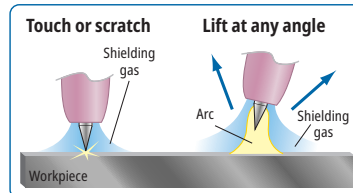

- Reduces or eliminates sticking
- Reduces or eliminates electrode/work contamination
- Low open-circuit voltage

## ARC END with Auto-Stop™

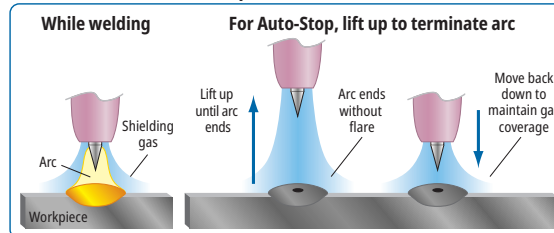

- Eliminates need for a remote control
- Maintains shielding gas coverage
- Eliminates tungsten and workpiece contamination
- Eliminates unwanted arc strikes outside the weld area

## ARC END with Auto-Crater™

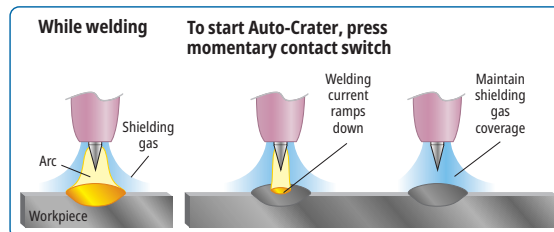

- Maintains shielding gas coverage
- Eliminates tungsten and workpiece contamination
- Auto-Crater time allows for addition of filler
- Eliminates unwanted arc strikes outside the weld area

# Genuine Miller® Accessories

## Wireless Interface Control Replacement Kit

**288137** Field  
Replacement kit for wireless interface control machines. NOT compatible with machines that are not equipped with wireless interface control. Includes replacement remote, magnetic lanyard, USB charger, 110-volt adapter, and two screen protectors.

## Wireless Interface Control Protective Covers

**287594** Field  
Five-pack of screen protectors for wireless interface control remote.



Female Receptacle

**Full KVA Adapter Cord 300517** Field  
NEMA 14-50P to NEMA 6-50R. Adapts engine drive 120/240 V plug to common Millermatic® and Spectrum® 240 V plug.



**Full KVA Plug Kit 119172** Field  
120/240 V, 50 A plug (NEMA 14-50P) to fit full KVA receptacle.



**International Plug 255416** Field  
1-phase, 240 V, 16 A plug

## Engine Filter Kits

**252782** For Mitsubishi (USA)  
**253901** For Kubota (USA/Int'l)  
Includes all filters required for proper engine maintenance. Oil filter, primary and secondary fuel filter, and primary air filter.



**Spark Arrestor (Muffler) Kit 300585** Field  
Prevents particles from leaving the muffler that could potentially start a

fire. Mandatory when operating on California grasslands, brush, or forest-covered land, and in all national forests. For other areas, check your state and local laws. Meets U.S. Forest Service Standard 5100-1B.



**FA-1D Lockable Flame Arrestor Fuel Cap 043947** Field  
Fuel cap can be padlocked to prevent vandalism. A built-in flame arrestor prevents flames or sparks from entering the fuel tank.

## Remote Output Panel Kit 951850

Field  
If your engine-driven welder is mounted on a truck, easily locate the outputs at the point of use with the auxiliary power and weld output remote panel. See literature AY/20.5.



## Protective Cover 195301

Field  
Blue water-resistant cover with Miller logo resists stains and mildew, and protects the finish of your welder.

## MIG/Flux-cored Welding



### ArcReach® SuitCase® 8

**951726001** With Bernard® BTB Gun 300 A  
**951727** With Bernard® S-Gun™  
**951728** With Bernard® Dura-Flux™ gun

### ArcReach® SuitCase® 12

**951729001** With Bernard® BTB Gun 300 A  
**951730** With Bernard® S-Gun™  
**951731** With Bernard® Dura-Flux™ gun

### ArcReach® SuitCase® 12 Heavy Duty

**301604** Feeder only — for 3/32-inch cored wire  
Portable feeder designed to run off of arc voltage. When paired with an ArcReach power source, provides remote control of the power source without a control cord — saving time and money. See literature M/6.55.



### ArcReach® Smart Feeder 951733

For use with ArcReach models only (see page 3 for more information). Includes drive rolls and Bernard® PipeWorx 300-15 MIG gun. For MIG, FCAW, and advanced RMD®

and pulse processes. See literature M/6.55.



## SuitCase® 12RC Wire Feeder 951580001

Lightweight and flexible enough to run wires up to .062-inch diameter. Includes remote voltage control, drive roll kit and Bernard® BTB Gun 300 A. See literature M/6.5.

## MIG (GMAW)/Flux-cored (FCAW) Guns

See Bernard® literature SP-BTB for BTB air-cooled MIG guns, and SP-DF for Dura-Flux™ self-shielded flux-cored guns.



## Spoolmatic® 30A Spool Gun 130831

Air-cooled, 200-amp, one-pound spool gun for aluminum and stainless MIG. See literature M/1.73. Requires WC-24 Control **137549**.

## XR™ Wire Feeders and Guns

Push-pull system designed to handle difficult-to-feed soft alloy wires such as aluminum. See literature DC/34.0 and M/1.71 through M/1.74.

## TIG (GTAW) Welding

*The Dynasty 210 power sources can be run off the engine drive's auxiliary power to provide two arcs with only one engine.*



**Dynasty® 210 Series**  
For portable AC/DC TIG. See literature AD/4.81.

## Multiple Operator Welding

*The XMT 350 FieldPro and CST 280 power sources can be run off the engine drive's auxiliary power to provide two arcs with only one engine.*



**XMT® 400 ArcReach®**  
See literature DC/18.97.



**CST™ 282**  
See literature DC/29.6.

# Genuine Miller® Accessories (Continued)

## Plasma Cutting



Spectrum 375 X-TREME and 625 X-TREME shown.

**Spectrum® 375 X-TREME™ 907529**

See literature PC/9.2.

**Spectrum® 625 X-TREME™ 907579**

See literature PC/9.6.

**Spectrum® 875 907583**

See literature PC/9.8.

The Spectrum 375 X-TREME and 625 X-TREME come complete with protective X-CASE™ (not shown).

## Stick/TIG Remote Controls



**ArcReach® Stick/TIG Remote 301325**

When paired with an ArcReach power source, provides remote control of the power source without a control cord —

saving time and money. See literature AY/14.5.



**RHC-14 Hand Control 242211020**

Miniature hand control for remote current, voltage and contactor control. Dimensions:

4 x 4 x 3.25 in. (102 x 102 x 82 mm).

Includes 20-foot (6 m) cord and 14-pin plug.



**Wireless Remote Hand Control 301582**

For remote current, voltage and contactor control.

Receiver plugs directly into the 14-pin receptacle of Miller machine. Up to 300-foot (91.4 m) operating range.

Wireless antenna kit **300749** is recommended.

**Wireless Antenna Kit 300749**

Recommended for improved reception.



**RMS-14 On/Off Control 187208**

Momentary-contact switch for contactor control. Rubber-covered pushbutton dome switch ideal for repetitive on-off applications. Includes 26.5-foot (8 m) cord and 14-pin plug.



**RCC-14 Remote Contactor and Current Control 151086**

East/west rotary-motion fingertip control attaches to TIG torch using two hook-and-loop fasteners. Includes 26.5-foot (8 m) cord and 14-pin plug.

**PRHC-14 Hand Control 195511**

Complete current or voltage control brings 120 volts GFCI power to work area in a single cord. Housed in a durable, light aluminum case and includes 125-foot (38 m) cord with plugs.

**Extension Cables for 14-Pin Remote Controls or 24 VAC Wire Feeders**

**242208025** 25 ft. (7.6 m)

**242208050** 50 ft. (15.2 m)

**242208080** 80 ft. (24.4 m)

## Trailers and Hitches (Note: Trailers are shipped unassembled.)



**HWY-Mid Frame Trailer 301438**

1,424-pound (646 kg) capacity highway trailer with welded steel tubing frame, heavy-duty axle with roller bearing hubs and leaf-spring suspension. Includes jack stand, fenders, lights, and dual hitch with 2-inch (50 mm) ball hitch and 3-inch (76 mm) lunette eye.

**Cable Tree 043826**

Provides an area to conveniently wrap weld cables and extension cords.



**Dual Hitch 301441**

Combination 2-inch (50 mm) ball hitch and 3-inch (76 mm) lunette eye in one reversible assembly.



**2-In-1 Document/Fire Extinguisher Holder 301236**

Stores documents and holds a 5-pound fire extinguisher.

*Note: Holder shown mounted on trailer. Fire extinguisher not included.*

## Mounting Specifications

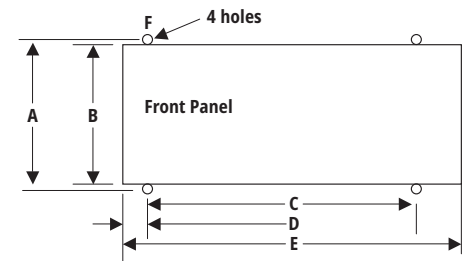

**A.** 27.75 in. (705 mm)

**B.** 26.25 in. (667 mm)

**C.** 52.25 in. (1,327 mm)

**D.** 2 in. (51 mm)

**E.** 56 in. (1,422 mm)

**F.** .562 in. (14 mm) diameter

**Height:** 32 in. (813 mm)

**Width:** 26.25 in. (667 mm)

**Depth:** 56 in. (1,422 mm)

## Trailer Specifications (Subject to change without notice.)

Model	Gross Axle Weight Rating	Gross Vehicle Weight Rating	Net Payload	Height of Bed	Road Clearance	Track (Center to center of tires)	Standard Tires (Standard rating or P-size rating)	Dimensions	Net Weight
HWY-Mid Frame	1,605 lb. (728 kg)	1,424 lb. (646 kg)	1,424 lb. (646 kg)	19.5 in. (495 mm)	8 in. (203 mm)	46 in. (1,168 mm)	ST175/80D-13 Load Range C	Length: 101 in. (2,565 mm) Width: 55 in. (1,397 mm)*	181 lb. (82 kg)

\*Width at outside of fenders.

# Ordering Information

Equipment and Options	Stock No.	Description	Qty.	Price
<b>Big Blue® 400 Pro (USA)</b>	<b>907732</b> <b>907733</b>	Kubota. USA model Mitsubishi. USA model		
<b>Big Blue® 400 Pro with ArcReach® (USA)</b>	<b>907732001</b> <b>907733001</b>	Kubota. USA model Mitsubishi. USA model		
<b>Big Blue® 400 Pro with ArcReach® and Wireless Interface Control (USA)</b>	<b>907732013</b>	Kubota. USA model <i>Note: Big Blue 400 PipePro has WIC models w/Mitsubishi engines</i>		
<b>Big Blue® 400 Pro with ArcReach® Trailer Package (USA)</b>	<b>951744</b>	Kubota. USA model. Includes Tweco®-style connectors and HWY-mid frame trailer with 2-in-1 document/fire extinguisher holder		
<b>Big Blue® 400X Pro (International)</b>	<b>907732010</b> <b>907732011</b>	Kubota. International model Kubota. International model with ArcReach®		
<b>Field Accessories</b>				
Wireless Interface Control Replacement Kit	<b>288137</b>	See page 6 for items included		
Wireless Interface Control Protective Covers	<b>287594</b>	Five-pack of screen protectors for wireless interface control remote		
Full KVA Adapter Cord	<b>300517</b>			
Full KVA Plug Kit	<b>119172</b>	120/240 V		
International Plug	<b>255416</b>			
Engine Filter Kits		See page 6		
Spark Arrestor (Muffler) Kit	<b>300585</b>			
FA-1D Lockable Flame Arrestor Fuel Cap	<b>043947</b>			
Remote Output Panel Kit	<b>951850</b>	For truck-mounted engine-driven welders. Includes auxiliary power and weld output remote panel		
Protective Cover	<b>195301</b>			
<b>MIG/Flux-cored Welding</b>				
Wire Feeders		See page 6		
MIG (GMAW) and Flux-cored (FCAW) Guns		See Bernard® literature SP-BTB and SP-DF		
Spoolmatic® 30A Spool Gun	<b>130831</b>	Requires WC-24 Control. See literature M/1.73		
WC-24 Control	<b>137549</b>	See literature M/1.73		
XR™ Wire Feeder Control and Guns		See literature DC/34.0 and M/1.71 through M/1.74		
<b>TIG Welding</b>				
		See page 6		
<b>Multiple Operator Welding</b>				
		See page 6		
<b>Plasma Cutting</b>				
		See page 7		
<b>Stick/TIG Remote Controls</b>				
ArcReach® Stick/TIG Remote	<b>301325</b>	For use with ArcReach models only		
RHC-14 Hand Control	<b>242211020</b>	Hand control with 20 ft. (6 m) cord		
Wireless Remote Hand Control	<b>301582</b>	Hand control with wireless 300 ft. (91.4 m) operating range		
Wireless Antenna Kit	<b>300749</b>	Recommended for improved reception		
RMS-14 On/Off Control	<b>187208</b>	Remote contactor control		
RCC-14 Remote Contactor and Current Control	<b>151086</b>	Fingertip control		
PRHC-14 Hand Control	<b>195511</b>	Hand control with 120 V GFCI receptacle, 125 ft. (38 m)		
Extension Cables		See page 7		
<b>Trailers and Hitches</b>				
HWY-Mid Frame	<b>301438</b>	Trailer with lights, fenders and dual hitch. For highway use		
Cable Tree	<b>043826</b>	Trailer-mounted cable holder		
Dual Hitch	<b>301441</b>	Combination 2 in. (50 mm) ball hitch and 3 in. (76 mm) lunette eye in one reversible assembly		
2-In-1 Document/Fire Extinguisher Holder	<b>301236</b>	Stores documents and holds a 5 lb. fire extinguisher		

Date:

Total Quoted Price:

Distributed by:

