

Series 35™

Issued May 2025 • Index No. GE/7.0



Medium-Duty Two-Stage Pressure Regulators

Quick Specs

Applications

Farm and ranch
Construction and fabrication
Heavy equipment
Shipbuilding
Scrap and salvage

Oxy-Fuel Processes

Cutting, heating, welding and brazing

Gas Service

Oxygen, acetylene and argon/nitrogen

Max. Delivery Pressure

Up to 125 psig (9 bar)

Max. Inlet Pressure 400 or 3,000 psig (28 or 207 bar)

Outlet Connection 9/16"-18 LH or RH "B" or 5/8"-18 RH internal

CGA Inlet Connection 510, 540 or 580

Regulator Body Inlet 1/4" NPT

Temperature Range -20°-+140°F (-29°-+60°C)

Consistent, accurate pressure. Reliable for daily use.



35-50-580



Sure Seat™

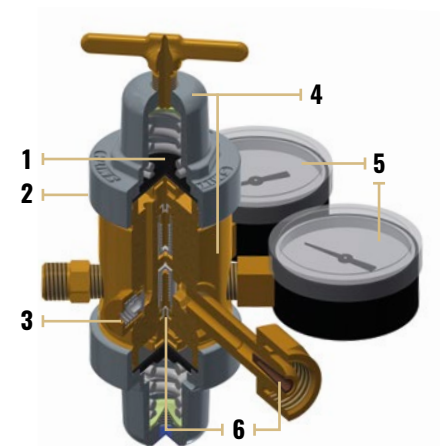

FEATURES

- 1. Neoprene composite diaphragm**
Resists corrosion for extended service life.
- 2. Color-coded label**
Supplies performance capabilities, easy gas service identification and technical information.
- 3. External relief valve**
Protects regulator from damage due to inadvertent high-pressure surge. Relief valve will release excessive pressure and automatically reset.
- 4. Brass body and nickel-plated bonnet**
Protects against corrosion.
- 5. Shatter-resistant 2-inch gauges**
Easy-to-read gauges with polycarbonate lens covers for protection.
- 6. Dual filters including Sure Seat™**
Protects high-pressure seat from debris for reliable operation and long service life.



Regulators are warranted for three years, parts and labor.



Underwriters Laboratories (UL) Listed



Smith Equipment

A Brand of Miller Electric Mfg. LLC
2601 Lockheed Avenue
Watertown, SD 57201

Equipment Sales US and Canada

Phone: 866-931-9730
International Phone: 920-735-4554

MillerWelds.com



Performance Data

These flow charts are used to determine whether or not your regulator has the flow capability necessary for your application.

How to use a flow chart:

There are multiple ways to use a flow chart. Each method relies on a pair of known values for inlet pressure, outlet pressure, or flow rate to determine the third. For example, if the inlet and outlet pressures are known and you wish to know the flow rate, the following steps may be used:

1. Identify curve corresponding to the system's inlet pressure. Different colors or symbols may be used to differentiate one inlet pressure from another.
2. Find desired outlet pressure on vertical axis.
3. Move horizontally across the chart until the line corresponding to the desired outlet pressure intersects the curve corresponding to the inlet pressure.
4. Read the flow rate marked along the horizontal axis.

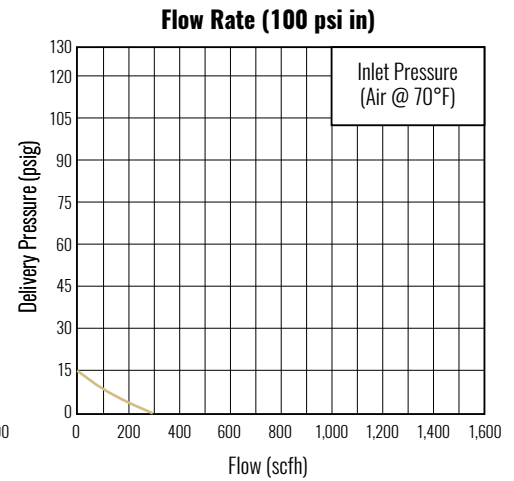
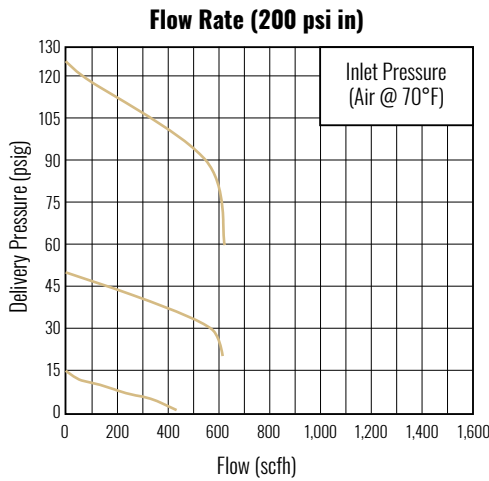
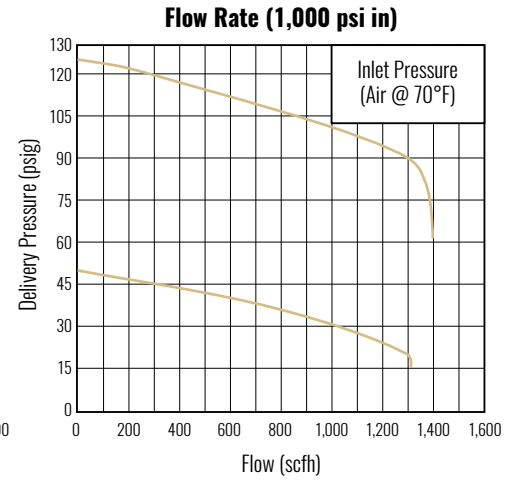
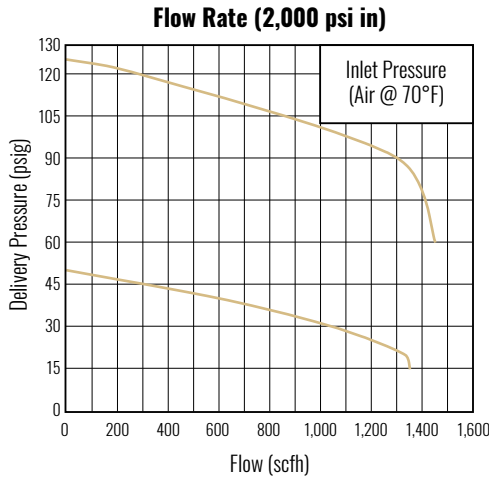

Ordering Information

REGULATOR	STOCK NUMBER	GAS SERVICE	INLET GAUGE	OUTLET GAUGE	DELIVERY PRESSURE	MAX. INLET PRESSURE	OUTLET CONNECTION	INLET CONNECTION
Medium-Duty Two-Stage Regulators	35-125-540	Oxygen	0-4,000 psig (0-280 bar)	0-150 psig (0-10 bar)	0-125 psig (0-9 bar)	3,000 psig (207 bar)	9/16"-18 RH "B"	CGA 540
	35-15-510	Acetylene	0-400 psig (0-28 bar)	0-30 psig (0-2 bar)	0-15 psig (0-1 bar)	400 psig (28 bar)	9/16"-18 LH "B"	CGA 510
	35-50-580	Argon/nitrogen	0-4,000 psig (0-280 bar)	0-60 psig (0-4 bar)	0-50 psig (0-3 bar)	3,000 psig (207 bar)	5/8"-18 RH internal	CGA 580

Distributed By:

