

SubArc Digital Series

**Submerged Arc
Welding Power Source** 

Quick Specs

Heavy Industrial Applications

Railcar
Shipbuilding
Heavy fabrication
Pipe manufacturing
Pressure vessel

Processes

Submerged arc (SAW)
Electroslag (ESW)
Air carbon arc cutting
and gouging (CAC-A)

Input Power

Requires 3-phase power

Rated Output

DC 650/800: 650 A at 44 V, 100% duty cycle
DC 1000/1250: 1,000 A at 44 V, 100% duty cycle
AC/DC: 1,000 A at 44 V, 100% duty cycle

SubArc Digital Series

- Choice of three power sources, two interface controls and a range of wire drive motors and accessories
- Digital process control technology
- Highly reliable thyristor power regulation
- Digital control and communication electronics improve weld performance and simplify the integration of the equipment in more advanced applications



SubArc DC 650/800 Digital

SubArc DC 1000/1250 Digital

SubArc AC/DC Digital

Easy to integrate.

Our SubArc power sources are easy to integrate by using a standard Modbus® connection. Different levels of integration are possible, from simple remote operation to more complex automated systems.



Two DC power source models and one AC/DC power source model.

Power sources have sufficient power capacity to cover applications from traditional DC single-arc to multi-wire tandem welding. In the case of electroslag welding or other high-current demand, two or more power sources can easily be paralleled (both DC and AC/DC machines).

Easier setup and operation.

The SubArc Digital Series interface controls recognize the power source and wire drive connected, and automatically configure the system for proper operation. The easy-to-understand interface provides the operator with the necessary controls to set process parameters and control output. The power sources feature simplified parallel and tandem setups — just plug the cable into the appropriate connectors.

Improved flux delivery system.

Our SubArc flux hopper utilizes a flux valve mechanism that assures continuous delivery of flux to the arc. The unique valve design provides a barrier between the flux and actuation device to help prevent jamming of the solenoid actuator due to dust and debris. A sight glass is provided on the front of the flux hopper allowing the weld operator to visually monitor the remaining flux in the hopper.

Low-voltage accessory operation and improved environmental protection.

The digital series accessories are powered with 24 VAC control voltage from the power source. All power sources, interface controls and wire drives are IP23 rated providing a high level of protection for harsh environments.

All power sources also feature thermal overload protection, line voltage compensation and Fan-On-Demand™



Power source is warranted for three years, parts and labor.
Original main power rectifier parts are warranted for five years.

Miller recommends



Miller Electric Mfg. LLC
An ITW Welding Company
1635 West Spencer Street
P.O. Box 1079
Appleton, WI 54912-1079 USA

Equipment Sales US and Canada
Phone: 866-931-9730
International Phone: 920-735-4554

MillerWelds.com



SubArc DC Digital



SubArc DC 650/800 Digital and DC 1000/1250 Digital cover most single- and twin-wire applications. These traditional transformer/rectifier power sources combine high efficiency with the highest reliability. They also feature state-of-the-art digital-control electronics to provide best-in-class welding performance and repeatability.

SubArc DC Digital Specifications (Subject to change without notice.)



Model	Amperage/Voltage Ranges	Rated Output	IP Rating	Amps Input at Rated Load Output, 60 Hz 230 V 460 V 575 V	Amps Input at Rated Load Output, 50 Hz 380 V 400 V 440 V	KVA	KW	Maximum Open-Circuit Voltage DC**	Dimensions	Net Weight
SubArc DC 650 Digital	50–815 A in CC mode	650 A at 44 V, 100% duty cycle	IP23	126 63 50.4 3.8* 1.9* 1.4*	— — —	50 1.52*	34.8 0.76*	75 Vpk	H: 30 in. (762 mm) (including lift eye) W: 23 in. (584 mm) D: 38 in. (965 mm) (not including strain relief)	593 lb. (269 kg)
SubArc DC 800 Digital	20–44 V in sub arc mode	815 A at 44 V, 60% duty cycle		— — — — — —	95 90 83 1.9* 1.8* 1.6*					603 lb. (273 kg)
SubArc DC 1000 Digital	100–1,250 A in CC mode	1,000 A at 44 V, 100% duty cycle	IP23	180 90 72 5.8* 2.9* 2.4*	— — —	73 3.2*	53 0.5*	68 Vpk		682 lb. (309 kg)
SubArc DC 1250 Digital	20–44 V in sub arc mode	1,250 A at 44 V, 60% duty cycle		— — — — — —	135 128 117 5.2* 5.0* 4.5*					681 lb. (309 kg)

*While idling. **Open-circuit voltages in CV mode are factory set at values less than indicated for CC.

SubArc DC 650 Digital and DC 1000 Digital models are certified by Canadian Standards Association to both the Canadian and U.S. Standards.

All SubArc DC Digital models are manufactured and certified in accordance with IEC-60974-1, -10.

SubArc DC Digital Control Panel

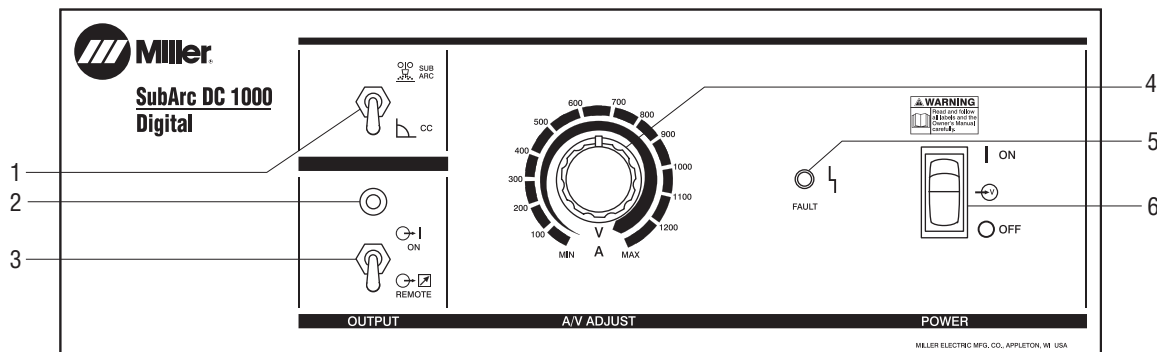

1. Process Selector Switch
2. Output Indicator Light
3. Output Switch (Contactor)

4. Amperage/Voltage Adjustment Control
5. Fault Indicator
6. Power Switch

SubArc AC/DC Digital



SubArc AC/DC Digital and SubArc AC/DC 1250 Digital. AC welding output enables the SubArc AC/DC to be used in tandem-arc welding systems with a DC lead arc and AC trailing arc, or with AC/AC arc combinations. Using multiple arcs increases deposition rate, resulting in shorter welding cycles for very thick weldments without compromising quality. All AC balance control modes can be set on the SubArc Interface Digital

or the SubArc Remote Pendant Digital. These easy-to-understand interfaces include two DC modes and 12 best-practice AC balance settings. In multiple-arc configurations, the system automatically adjusts the phase shifting between power sources thereby eliminating arc interaction. There is no need to employ a laptop PC for complex wave shaping before operation.

SubArc AC/DC Digital Specifications (Subject to change without notice.)



Model	Amperage/ Voltage Ranges	Rated Output	IP Rating	Amps Input at Rated Load Output				KVA	KW	Maximum Open-Circuit Voltage DC	Dimensions	Net Weight
				460 V (60 Hz)	380 V (50 Hz)	400 V (50 Hz)						
SubArc AC/DC Digital	300–1,250 A in CC mode	1,000 A at 44 V, 100% duty cycle	IP23	122 3.0*	—	—	98	53	93 Vpk	H: 43 in. (1,092 mm) (including lift eye) W: 28 in. (711 mm) D: 48 in. (1,219 mm) (not including strain relief)	1,187 lb. (538 kg)	
SubArc AC/DC 1250 Digital	20–44 V in sub arc mode	1,250 A at 44 V, 60% duty cycle		—	179 3.0*	176 3.0*	122 2.37*	67 0.95*			1,260 lb. (572 kg)	

*While idling.

SubArc AC/DC Digital is certified by Canadian Standards Association to both the Canadian and U.S. Standards.

Both SubArc AC/DC Digital models are manufactured and certified in accordance with IEC-60974-1, -10.

SubArc AC/DC Digital Control Panel

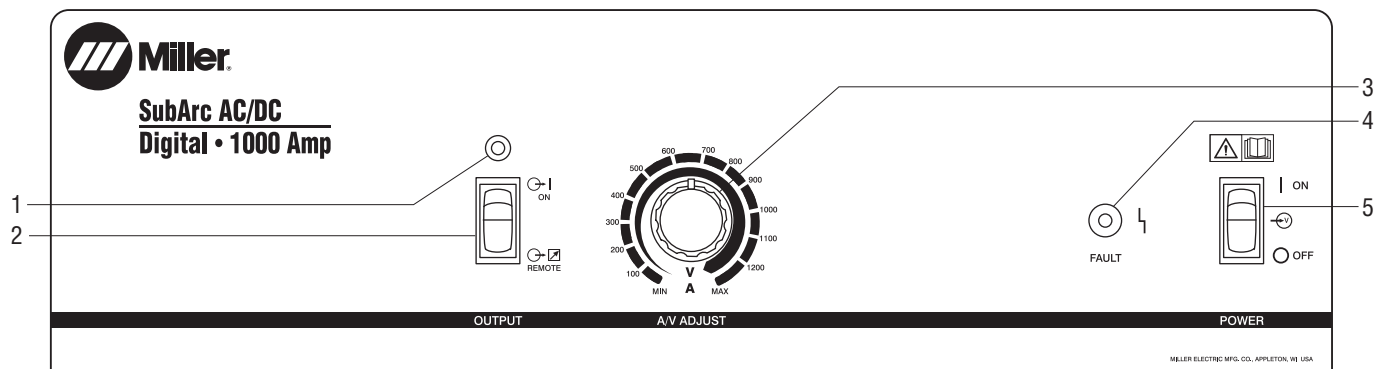

- 1. Output Indicator Light
- 2. Output Switch (Contactor)
- 3. Amperage/Voltage Adjustment Control
- 4. Fault Indicator
- 5. Power Switch

SubArc Interface



SubArc Interface Digital

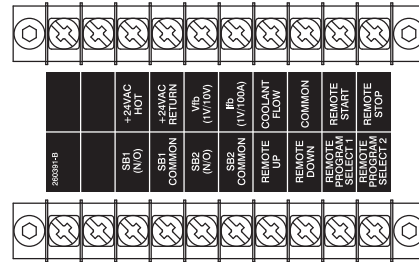

Internal terminal strip is able to integrate with positioners, sidebeams, turning rolls and other peripheral equipment.

SubArc Interface Specifications (Subject to change without notice.)

Model	Input Power from Welding Power Source	Welding Power Source Type	Weld Voltage and Amperage Capacity	Dimensions	Net Weight
SubArc Interface Digital	24 VAC, single-phase, 25 A, 50/60 Hz	Constant voltage (CV), AC or DC, with remote contactor and output control capabilities	0–100 V 0–1,500 A	H: 11.5 in. (292 mm) W: 12 in. (305 mm) D: 7 in. (178 mm)	15.8 lb. (7.2 kg)

Certified by Canadian Standards Association to both the Canadian and U.S. Standards.

Manufactured according to the Standard IEC-60974-1, -5, -10.

SubArc Interface Control Panel

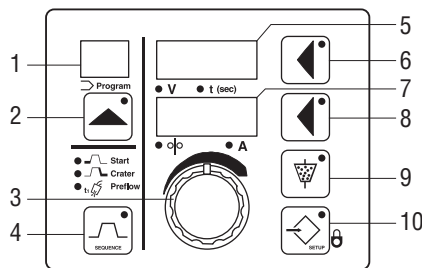

- 1. Program Display
- 2. Program Push Button
- 3. Adjust Control
- 4. Sequence Push Button
- 5. Upper Display
- 6. Upper Display Push Button
- 7. Lower Display
- 8. Lower Display Push Button
- 9. Flux Push Button
- 10. Setup Push Button
- 11. Start Button
- 12. Power Switch
- 13. Stop Button
- 14. Wire Inch Up
- 15. Wire Inch Down

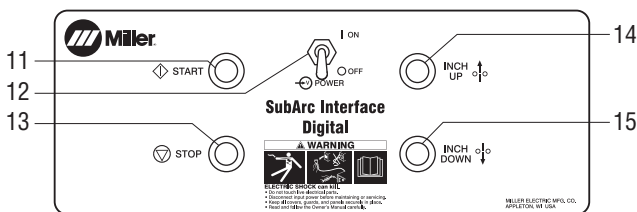

SubArc Interface Digital

SubArc Remote Operator Interface



Motor Control Digital

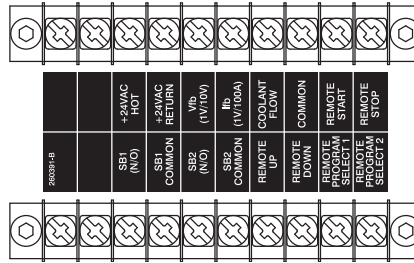

Internal terminal strip inside Motor Control Digital is able to integrate with positioners, sidebeams, turning rolls and other peripheral equipment.



Remote Pendant Digital

SubArc Remote Operator Interface Specifications (Subject to change without notice.)

Model	Input Power from Welding Power Source	Welding Power Source Type	Weld Voltage and Amperage Capacity	Dimensions	Net Weight
Motor Control Digital	24 VAC, single-phase, 25 A, 50/60 Hz	Constant voltage (CV), AC or DC, with remote contactor and output control capabilities	0–100 V 0–1,500 A	H: 11.5 in. (292 mm) W: 12 in. (305 mm) D: 7 in. (178 mm)	15.8 lb. (7.2 kg)
Remote Pendant Digital	42 VDC, 1 A			H: 11 in. (279 mm) W: 10.63 in. (270 mm) D: 3.125 in. (80 mm)	3 lb. (1.4 kg)

Certified by Canadian Standards Association to both the Canadian and U.S. Standards.

Manufactured according to the Standard IEC-60974-1, -5, -10.

SubArc Remote Operator Interface Control Panels

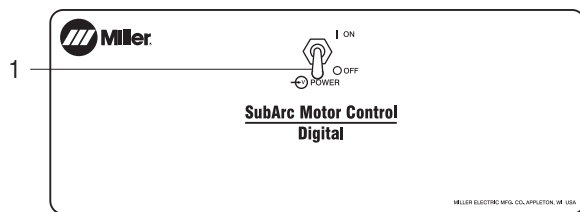

Motor Control Digital

1. Power Switch

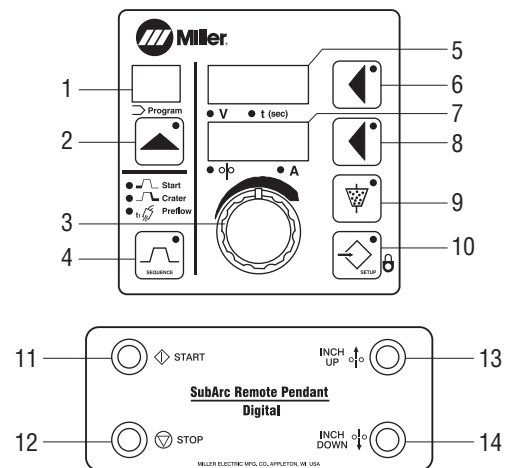

Remote Pendant Digital

- | | |
|------------------------------|------------------------------|
| 1. Program Display | 8. Lower Display Push Button |
| 2. Program Push Button | 9. Flux Push Button |
| 3. Adjust Control | 10. Setup Push Button |
| 4. Sequence Push Button | 11. Start Button |
| 5. Upper Display | 12. Stop Button |
| 6. Upper Display Push Button | 13. Wire Inch Up |
| 7. Lower Display | 14. Wire Inch Down |

SubArc Interface and Remote Operator Interface Setups

SubArc Interface Setup

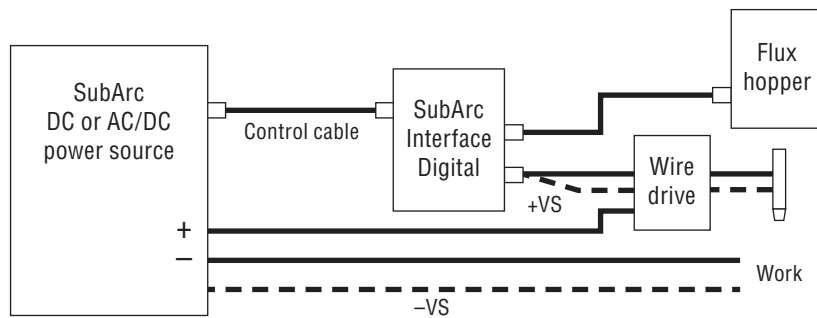

The positive sense lead is integrated in the wire feeder motor cable and control cable. A customer supplied negative sense lead is required for optimal performance.

SubArc Remote Operator Interface Setup

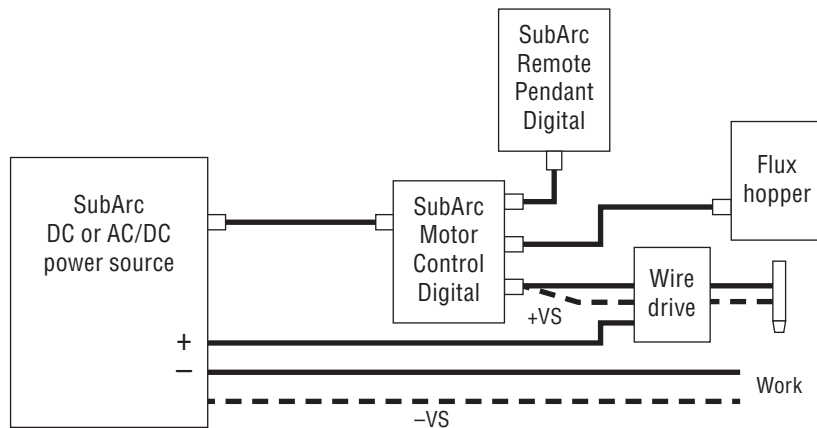

SubArc Modbus® Setups

Easy Method

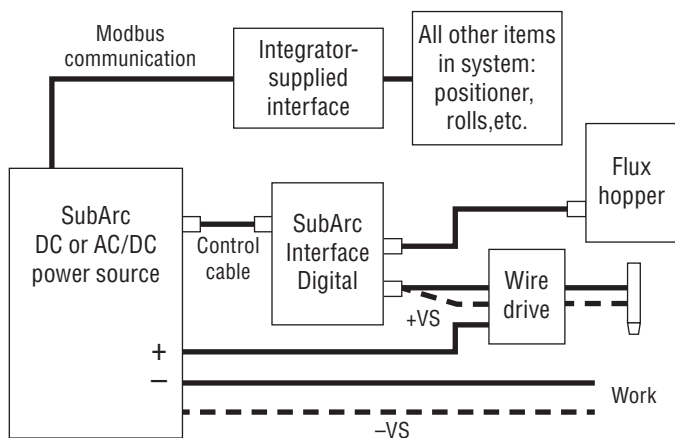

Easy method of integrating standard components while controlling them over Modbus communication. Using the standard SubArc interface, wire feed motor and flux hopper, an integrator can remotely adjust settings and operation of the SubArc interface. A separate document with interfacing information is available.

High-Level Method

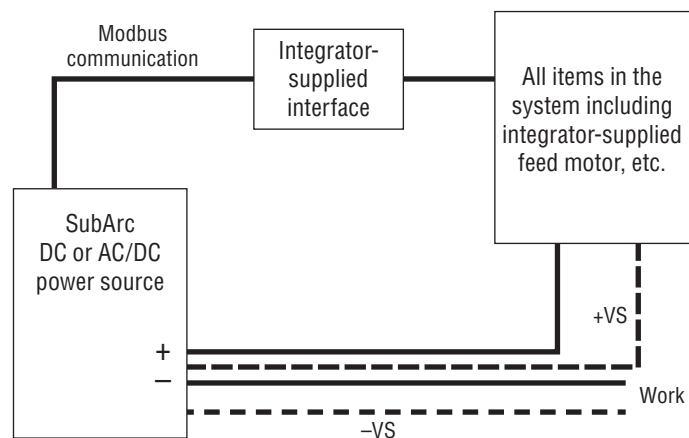

High-level method where the integrator solely uses the digital power sources and controls them over Modbus communication. Benefits from Miller technology-driven arc performance while integrating into a custom-made welding solution.

SubArc System Parallel and Tandem Setups

Parallel setup. Only like power sources can be paralleled. Paralleling of two machines to increase maximum welding current is simply done by connecting the paralleling cable from RC2 on the first unit to RC1 on the second unit. This works for both DC as well as AC/DC machines. Daisy chaining multiple machines to gain higher output is done in the same way. No special tools, laptop or software needed... plug and play.

Parallel Connections

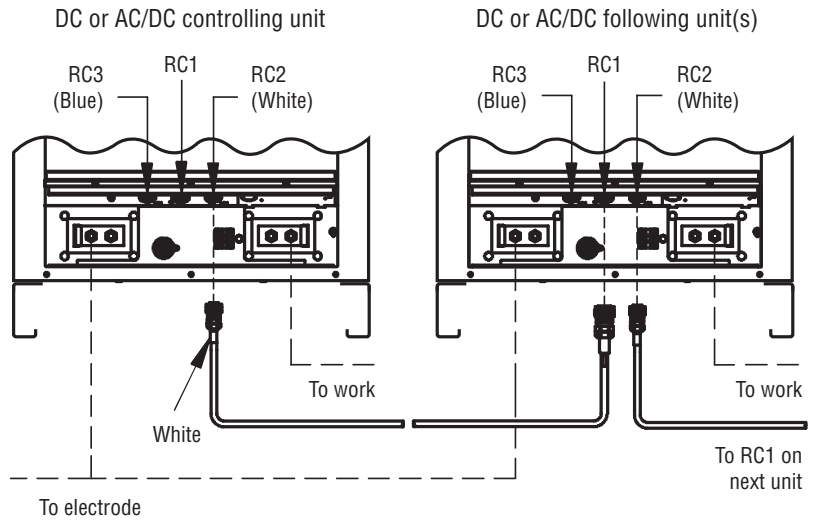

Tandem setup. To use two or more AC arcs, the arc must be phase shifted to prevent arc to arc interaction. This is simply done by connecting the tandem cable from RC2 on the first unit to RC3 on the second unit. This automatically sets the optimum phase shift for AC welding. No special tools, laptop or software needed... plug and play.

Tandem Connections

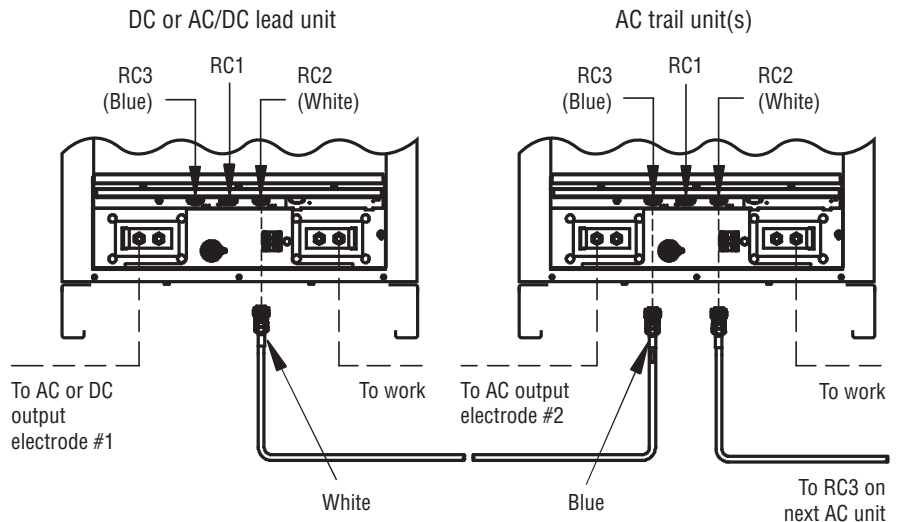

Wire Drive Assembly

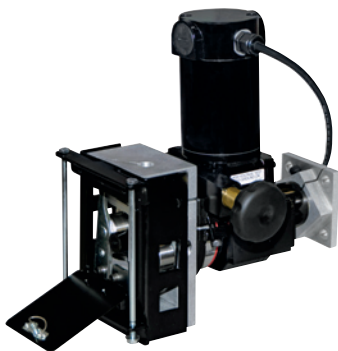

SubArc Wire Drive 400 Digital Low Voltage 300938

Standard-speed, right-angle wire drive assembly.

SubArc Wire Drive 200 Digital Low Voltage 301596

Low-speed, right-angle wire drive assembly.

Specifications (Subject to change without notice.)

Model	Input Power	Input Power Cord	Rating	Wire Feed Speed	Wire Diameter Capacity	Net Weight
SubArc Wire Drive 400 Digital Low Voltage	38 VDC	4 ft. (1.2 m)	1/5 hp, 85 rpm	30–400 ipm (0.8–10.2 m/min.)	1/16–5/32 in. (1.6–4.0 mm)	26 lb. (11.8 kg)
SubArc Wire Drive 200 Digital Low Voltage			1/5 hp, 42 rpm	20–200 ipm (0.5–5.1 m/min.)	1/8–3/16 in. (3.2–4.8 mm)	

SubArc Digital Converter



SubArc Digital Converter 301578

Enables you to use digital SubArc accessories with Big Blue welder/generators and the Dimension 650 for one all-inclusive SubArc solution. Also compatible with select older power sources (see list below).

Specifications (Subject to change without notice.)

Model	Input Power from Welding Power Source	Weld Voltage Capacity	Dimensions	Net Weight
SubArc Digital Converter	120 VAC, single-phase, 5 A, 50/60 Hz	0–100 V	H: 12 in. (305 mm) W: 13.75 in. (349 mm) D: 5.4 in. (137 mm)	25 lb. (11.3 kg)

 Certified by Canadian Standards Association to both the Canadian and U.S. Standards.

 Manufactured according to the Standard IEC-60974-1, -5, -10.

SubArc Digital Converter Setup

This diagram shows a Big Blue® power source, SubArc Digital Converter and SubArc 3-Wheel Tractor.

The SubArc Digital Converter is compatible with the following list of power sources to enable use of digital SubArc accessories.

Engine drives:

- Big Blue 500 Pro (See literature ED/11.0)
- Big Blue 600 Series (See literature ED/11.5)
- Big Blue 800 Series (See literature ED/14.0)

Multiprocess:

- Dimension 650 (See literature ED/19.3)

The SubArc Digital Converter is also compatible with the following older power sources:

- Deltaweld 452 and 652
- Dimension 452, 652 and 1000
- Subarc (non-digital) DC Series

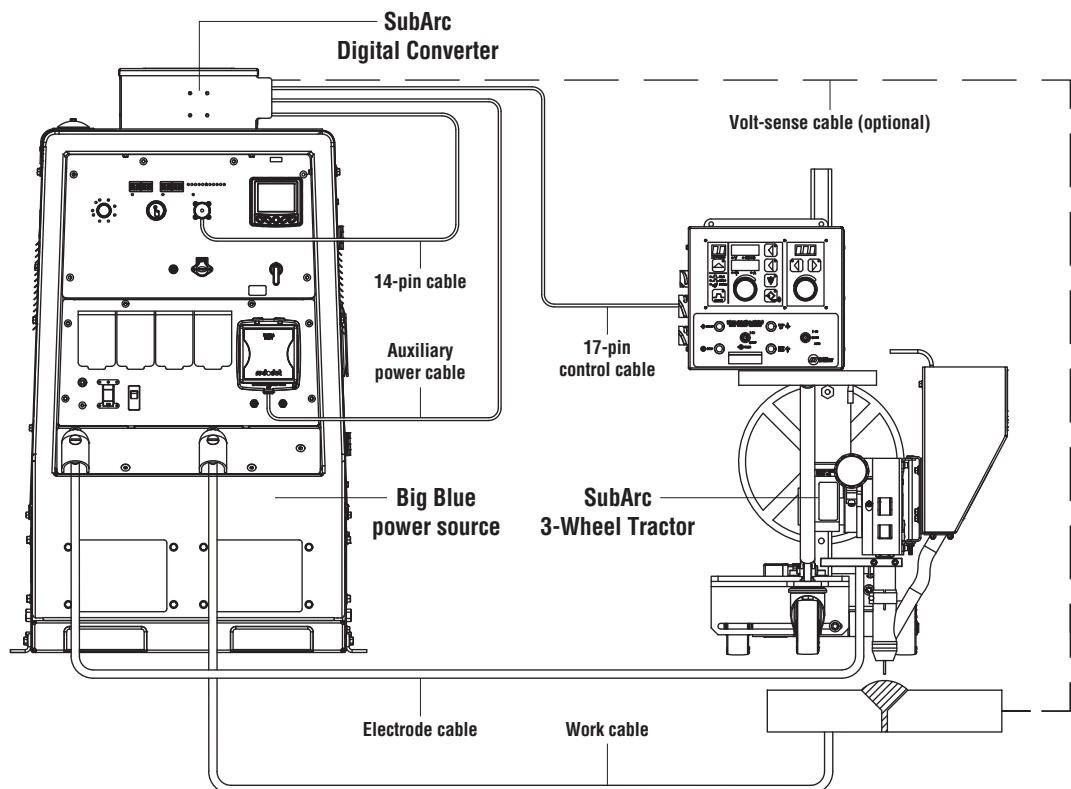

Accessories

Drive Rolls

- 132955 1/16 in. (1.6 mm)
- 132960 5/64 in. (2.0 mm)
- 132961 3/32 in. (2.4 mm)
- 132962 7/64 in. (2.8 mm)
- 132963 1/8 in. (3.2 mm)
- 193700 5/32 in. (4.0 mm)

Cables



SubArc Control Cables

- 260622030 30 ft. (9.1 m)
- 260622050 50 ft. (15.2 m)
- 260622060 60 ft. (18.3 m)
- 260622080 80 ft. (24.4 m)
- 260622100 100 ft. (30.5 m)
- 260622120 120 ft. (36.6 m)
- 260622200 200 ft. (61.0 m)

Cable between SubArc Interface or Motor Control and power source.



Flux Hopper Extension Cables

- 260623010 10 ft. (3 m)
- 260623025 25 ft. (7.6 m)
- 260623065 65 ft. (19.8 m)

Cable between SubArc Interface or Motor Control and flux hopper.



Motor Extension Cables

- 254232005 5 ft. (1.5 m)
- 254232010 10 ft. (3 m)
- 254232025 25 ft. (7.6 m)
- 254232065 65 ft. (19.8 m)

Cable between SubArc Interface or Motor Control and drive motor.



Continuum Motor/Control Cables

- 263368015 15 ft. (4.6 m)
- 263368020 20 ft. (6.1 m)
- 263368025 25 ft. (7.6 m)
- 263368050 50 ft. (15.2 m)
- 263368080 80 ft. (24.4 m)
- 263368100 100 ft. (30.5 m)

Cable between SubArc Motor Control and SubArc Remote Pendant.



SubArc Parallel Cable
260775015
15 ft. (4.6 m)



SubArc Tandem Cable
260878015
15 ft. (4.6 m)

Submerged Arc Torches



OBT 600 043923
600 amps at 100 percent duty cycle. For 1/16–5/32 inch (1.6–4.0 mm) wire. Torch has concentric flux flow nozzle.

OBT 600 Torch Body Extensions

- 043967 1 in. (25.4 mm)
- 043969 2 in. (50.8 mm)
- 043973 4 in. (101.6 mm)
- 043975 6 in. (152.4 mm)



OBT 1200 043900
1,200 amps at 100 percent duty cycle. For 1/16–5/32 inch (1.6–4.0 mm) wire. Torch has concentric flux flow nozzle and features a replaceable breakaway adapter end to prevent costly damage should torch run into an obstruction.

OBT 1200 Torch Body Extension 043981

Overall length with extension is 9 inches (228.6 mm). Actual length of extension is 8.5 inches (215.9 mm).

OBT Torch Contact Tips

OBT 600	OBT 1200	Wire Size
192700	192141	1/16 in. (1.6 mm)
192701	199026	5/64 in. (2.0 mm)
192702	192142	3/32 in. (2.4 mm)
192703	200771	7/64 in. (2.8 mm)
192704	192143	1/8 in. (3.2 mm)
192705	192144	5/32 in. (4.0 mm)



1200-Amp Twin-Wire Torch
301144 Long, 16.8 in. (427 mm)
1,200 amps at 100 percent duty cycle. For 3/64–3/32 inch (1.2–2.4 mm) wires.

1200-Amp Twin-Wire Torch Contact Tips

- 264595 3/64 in. (1.2 mm)
- 264596 1/16 in. (1.6 mm)
- 264597 5/64 in. (2.0 mm)
- 264588 3/32 in. (2.4 mm)



Single-Wire Straightener
199733
For use with OBT 600 and OBT 1200 single-wire torches. For 1/16–5/32 inch (1.6–4.0 mm) wires.



Twin-Wire Straightener
301160
Single adjustment for 1200-amp twin-wire torch only.



SubArc Flux Hopper Digital Low Voltage 300942
25-pound-capacity flux hopper with automatic flux valve. The opening is sized to allow hook-up of any flux-hopper-mounted recovery system. Includes slag screen and 11-foot (3.3 m) power cable.



Wire Reel 108008
For 60-pound (27 kg) coil of wire. Requires Spool Support Assembly (119438).

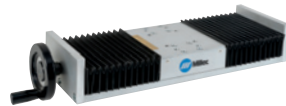

Manual Slide 301137
Manual slide for smooth and accurate movement of the welding head. Slide allows for 7.87 inch (200 mm) travel adjustment with load capacity of 220 pounds (100 kg) at 1.64 feet (500 mm). **Not recommended for tandem.**



SubArc Single Mounting Bracket 301134
Single mounting bracket configures single-arc welding head to mount to manual slide.



SubArc Tandem Mounting Bracket 301135
Tandem mounting bracket is a predesigned welding head configuration for tandem applications. Independent adjustments of lead and trail torches adapt to most applications.



SubArc Mounting Hinge 301136
Mounting hinge allows welding head to swivel 90 degrees with minimal effort. Ideal for changing from longitudinal to circumferential welds.

Typical Installations (SubArc Interface and Remote Operator Interface Setups.)

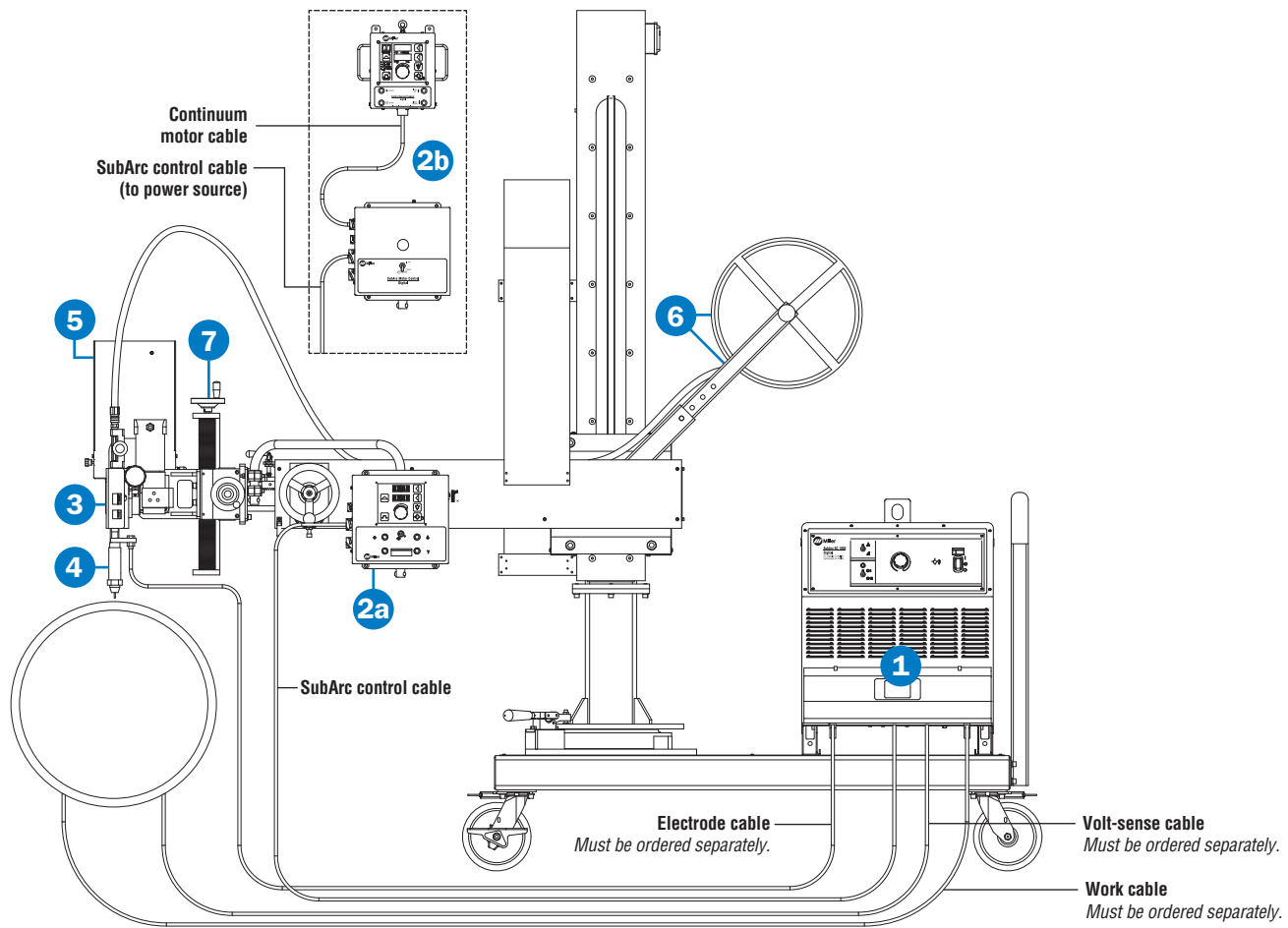

1 Power Source

See page 12 for available models.

2 Interface (choose one)

- a **SubArc Interface Digital** — See page 12. Requires a SubArc control cable to connect power source to interface. See page 9 for available cable lengths.
- b **SubArc Remote Operator Interface** — See page 12. Consists of SubArc Motor Control Digital and SubArc Remote Pendant Digital. Requires a Continuum motor cable and a SubArc control cable. See page 9 for available cable lengths.

3 Drive Motor

See page 12 for available models. Includes 4-foot (1.2 m) motor control cable. See page 9 for optional cable extension lengths and required drive rolls.

4 Torch (choose one)

- a **Single-Wire** — See page 9 for single-wire torches, optional body extensions and required contact tips. See page 10 for optional wire straightener.
- b **Twin-Wire** — See page 9 for twin-wire torch and required contact tips. See page 10 for optional wire straightener.

5 Flux Hopper

See page 10. Includes 11-foot (3.3 m) flux hopper cable. See page 9 for optional cable extension lengths.

6 Reel/Spool Assembly

See page 10. Wire reel requires spool support assembly.

7 Manual Slide

See page 10.

Ordering Information

Equipment and Options	Stock No.	Description	Qty.	Price
1 Power Source				
SubArc DC 650 Digital	907622	230/460/575 V, 60 Hz		
SubArc DC 800 Digital (50 Hz) CE	907623	380/400/440 V, 50 Hz		
SubArc DC 1000 Digital	907624	230/460/575 V, 60 Hz		
SubArc DC 1250 Digital (50 Hz) CE	907625	380/400/440 V, 50 Hz		
SubArc AC/DC Digital	907620	460 V, 60 Hz		
SubArc AC/DC 1250 Digital (50 Hz) CE	907621	380/400 V, 50 Hz		
2a Interface Controls and Cables				
SubArc Interface Digital	300936	CV, AC/DC digital control		
SubArc Control Cables		See page 9		
2b				
SubArc Motor Control Digital	301425	Motor control for Remote Pendant Digital		
SubArc Remote Pendant Digital	301424	CV, AC/DC digital control, requires 301425 and Continuum motor/control cable		
Continuum Motor/Control Cables		See page 9		
SubArc Control Cables		See page 9		
3 Drive Motors, Extension Cables and Rolls				
SubArc Wire Drive 400 Digital Low Voltage	300938	Standard-speed right-angle drive assembly		
SubArc Wire Drive 200 Digital Low Voltage	301596	Low-speed right-angle drive assembly		
Motor Extension Cables (if needed)		See page 9		
Drive Rolls		See page 9		
4a Single-Wire Torches, Straightener and Tips				
OBT 600	043923	600 amps, 100% duty cycle, air cooled		
OBT 1200	043900	1,200 amps, 100% duty cycle, air cooled		
OBT Torch Body Extensions (if needed)		See page 9		
Single-Wire Straightener	199733	For single-wire torches		
Contact Tips		See page 9		
4b Twin-Wire Torch, Straightener and Tips				
1200-Amp Twin-Wire Torch	301144	Long, 16.8 in. (427 mm), 1,200 amps, 100% duty cycle		
Twin-Wire Straightener	301160	Single adjustment for twin-wire torch only		
Contact Tips		See page 9		
5 Flux Hopper and Cables				
SubArc Flux Hopper Digital Low Voltage	300942	25 lb. (11 kg) flux capacity		
Flux Hopper Extension Cables (if needed)		See page 9		
6 Reel/Spool Assembly				
Wire Reel	108008	For 60 lb. (27 kg) coil, requires 119438		
Spool Support Assembly	119438			
7 Slide				
Single Manual Slide	301137	7.87 in. (200 mm) travel adjustment		
Accessories				
SubArc Digital Converter		See page 8		
SubArc Parallel/Tandem Cables		See page 9		
SubArc Brackets/Hinge		See page 9		
Additional SubArc Digital Systems				
SubArc Hercules System		See page 12		
SubArc 3-Wheel Tractor Digital Package		See page 12		
SubArc Portable Welding System		See page 12		

Date:

Total Quoted Price:

Additional SubArc Digital Systems

SubArc Hercules System

SubArc Hercules high-deposition submerged arc welding (SAW) is made possible by a combination of Hobart® and Miller®.

Hobart SubCOR® wire was developed to achieve the high-deposition rates possible. This unique Hobart filler metal was specially formulated to maintain arc stability at these high-deposition rates whereas other wire formulations lose arc stability and seize up over time.

The SubArc Hercules torch features two separate contact tips that allow two sources of power input, enabling the high-deposition process by resistive conditioning of the wire. This torch was specifically created for the SubArc Hercules process to ensure smooth feeding performance at elevated wire temperatures and deposition rates.

SubArc Hercules switch kit provides the ability to alternate between a standard SAW process and SubArc Hercules with the flip of a switch.

Coordination of all the components along with the unique formulation of the filler metal wire is what makes the SubArc Hercules process work. Hercules customers have enjoyed on average up to 30 percent and often higher deposition rate improvement over welding processes they previously considered best in class, raising the bar for state-of-the-art, high-deposition-rate welding productivity.

See literature DC/19.95 for more information.



Hobart SubCOR™ wire

- Developed to achieve the highest-deposition rates possible
- SubCOR (1/8 and 5/32 in. diameters)
 - SubCOR EM13K-S MOD (70 ksi tensile)
 - SubCOR 92S (80 ksi tensile)
 - SubCOR N1-S (70 ksi tensile for weathering steel)
 - SubCOR 100F3-S (90 ksi tensile)
 - SubCOR 120-S (110 ksi tensile)



SubArc Hercules torch

- Based on standard Miller® OBT 1200 torch
- Air-cooled
- Two contact tips
 - Preheat contact tip (upper contact tip) is a standard OBT 600
 - Welding tip (lower contact tip) is a standard OBT 1200



SubArc power source

- Compatible with all SubArc equipment
 - SubArc DC 650 Digital
 - SubArc DC 1000 Digital
 - SubArc AC/DC Digital
 - Legacy 14-pin SubArc equipment



XMT® 450 SAW Hercules power source

- Provides secondary electrical current for SubArc Hercules process
- XMT 450 with modified software lower voltage (1–10 volts)
- CV only

Note: This XMT can only be used for SubArc Hercules. It will NOT support other processes.



SubArc Hercules preheat switch

- Simple enable/disable switch
- LED on when enabled

No special wire drive or interface required.

SubArc Portable Systems

Miller offers two portable SubArc systems. These versatile, field-ready solutions allow you to bring the power of the SubArc family wherever you work.



SubArc 3-Wheel Tractor Digital Package 951755

Package includes SubArc 3-Wheel Tractor, SubArc Tractor Interface Digital, SubArc Wire Drive 400, 10-pound (4.5 kg) capacity flux hopper with manual valve, 60-pound (27 kg) wire reel, OBT 600 torch and wire straightener. See literature AD/7.7 for more information. **Does NOT include SubArc Digital Series power source — order separately.**



SubArc Portable Welding System

951675 With SubArc DC 650 Digital
951676 With SubArc DC 1000 Digital
951677 With SubArc AC/DC Digital
SubArc Portable Welding System is a ready-to-weld submerged arc system for pressure vessel, pipe and welding that requires positioning equipment which can adapt to your application. See literature AD/7.6 for more information.

Distributed by:

