



TOGETHER,  
**WE SHAPE THE FUTURE**  
OF WELDING AND CUTTING.

2019 *PRODUCT CATALOG*



**VICTOR**  
AN ESAB BRAND

**THERMAL  
DYNAMICS**  
AN ESAB BRAND

**TWECO**  
AN ESAB BRAND

**ARCAIR**  
AN ESAB BRAND

# WE SHAPE THE

As fabricators and fabricators' friends, we do some pretty epic work. And none of it would be possible without each and every one of us – the welders,

**SKYSCRAPERS.** the distributors,  
**MUSCLE CARS.** the engineers,  
**WIND TURBINES.** the tools of  
**OIL RIGS.** the trade.

Across the welding and fabrication world, the skills we have and the everyday work we do varies greatly, but our commitment to that work and to how fabrication moves the world forward is a constant that keeps us all reaching for more.

Together, **we shape the future** of welding and cutting.





# THE FUTURE



## KEEP UP WITH OUR NEWEST SOLUTIONS

We highlight all of our new and recent product launches in our **Launch Magazine**.

Learn about ESAB solutions engineered to deliver multi-voltage flexibility, superior multi-process arc control, lower consumables cost, user-friendly operation and more.

Visit [esab.com/launchmagazine](http://esab.com/launchmagazine) to subscribe today.



### VISIT OUR WEBSITE FOR MORE INFORMATION ON:

- WELDING AUTOMATION
- CUTTING AUTOMATION
- MIG GUN CONSUMABLES
- FILLER METALS
- STEEL INDUSTRY PRODUCTS

### FIND A DISTRIBUTOR

Looking for a product or ready to purchase?

Visit [esab.com](http://esab.com) to find an ESAB distributor in your area.

### ESAB TRAINING

Web-based training content is available for free! Browse our course material online or contact our training team to book onsite training at our facilities or yours.

Visit [esab.com/training](http://esab.com/training) to learn more.

## PRODUCT CATEGORIES

ARC WELDING EQUIPMENT .....	7
GAS EQUIPMENT .....	87
ARC GOUGING & EXOTHERMIC CUTTING.....	161
MANUAL PLASMA.....	189
PPE & ACCESSORIES .....	207

## STAY CONNECTED



[esab.com](http://esab.com)



[facebook.com/esabna](https://facebook.com/esabna)



[@esabweldingcutting](https://@esabweldingcutting)



[twitter.com/esabglobal](https://twitter.com/esabglobal)



[linkedin.com/company/esab](https://linkedin.com/company/esab)



[youtube.com/esabweb](https://youtube.com/esabweb)

Stay updated by joining our e-news mailing list at [esab.com/news](http://esab.com/news).

# OUR BRAND FAMILY.

ESAB's strong, diversified portfolio of products and offerings is unmatched in our industry. This enables us to better serve our customers and their needs and shape the future of welding and cutting together.



## The World Leader in the Production of Welding and Cutting Equipment and Consumables.

Our innovative, world-renowned equipment and solutions are developed with input from our customers and built with the expertise and heritage of a global manufacturing leader.



## The Leader in Arc Welding Accessories and MIG Guns

Tweco is the industry leader in arc welding accessories, which includes Tweco MIG guns a popular choice among professional welders.



## The Leader in Gas Equipment

Victor Gas Equipment's tradition of unparalleled safety, performance and reliability remains a cornerstone of the brand.



## The Recognized Inventor and Leading Producer of Hardfacing Alloys

Stoody is the leader in hardfacing technology and high alloy filler metals. We formulate products that maximize uptime, extend life cycle and reduce operating cost.



## The Standard in Plasma Cutting Performance.

Thermal Dynamics invented the modern plasma electrode, created the lightweight manual plasma cutter category and has redefined high-precision productivity.



## The Recognized Inventor of Arc Gouging and Exothermic Cutting

Arcair is a world leader in air carbon-arc gouging and exothermic cutting products.



## IAN JOHNSON OFFICIAL SPOKESPERSON

We are excited to announce our partnership with off-road and vehicle fabrication expert Ian Johnson, the official spokesperson of ESAB Welding & Cutting Products, North America.

Over the last few years, Ian has been a strong supporter of the ESAB brand on social media, and a staple in our booth at both the SEMA and FABTECH trade shows, providing insight and hands-on demonstrations for hundreds of attendees trying out our Rebel welders.

Ian recently visited our Technology and Research Center in Hanover, PA to film a series of videos focused on specific products and how-to tips. Visit our [YouTube](#) channel to check out the series.

In addition to working with Ian, ESAB will also be the official welding and cutting sponsor of **Big Tire Garage** – Ian's new digital show on Amazon Prime, Facebook and YouTube. Viewers will get to watch off-road, heavy fabrication projects from start to finish.

Follow along on ESAB's social media channels for updates throughout this exciting partnership.

## KNOWLEDGE CENTER

Whether you're new to welding or a veteran fabricator, check out ESAB's Knowledge Center for resources to master your craft.

Learn more at [esab.com/knowledge](https://esab.com/knowledge).



## **TURBOTORCH**

AN ESAB BRAND

### **The Leader in Brazing and Soldering**

TurboTorch is the leading provider air fuel brazing and soldering products, which includes portable welding torches, oxy-acetylene gauges and more.



AN ESAB BRAND

### **The Most Trusted Name in Aluminum Welding**

AlcoTec is the world's largest producer and the foremost expert in the production of aluminum welding wire.

## **EXATON**

AN ESAB BRAND

### **Premium Stainless Steel and Nickel Alloys**

Exaton (formerly Sandvik Welding Operations) specializes in crafting the highest-quality filler metals with unwavering consistency for welding stainless steel and nickel alloys in the most-demanding environments.



AN ESAB BRAND

### **The Leader in Measurement and Monitoring for Welding Technology.**

HKS develops, manufactures and distributes high-quality measurement and monitoring solutions for all welding processes. The product range covers the entire range of electrical and thermographic monitoring and process analysis methods from the sensor to sophisticated welding analysis systems.



AN ESAB BRAND

### **The Leader in Orbital TIG Welding**

Arc Machines, Inc. delivers the world's broadest and most advanced range of automated orbital tube and pipe TIG welding equipment and application expertise.

## **MEET THE ELITE.**



**T**heir talent is undeniable. Their creativity, unparalleled. And their work can only be described as awesome. Now, some of the industry's top welders are teaming up

with ESAB to show off their latest projects and share their wisdom. So follow along – because if you want to be the best, you have to learn from the best.

Find out more at [esab.com/elite](http://esab.com/elite).



ESAB and **Arc Junkies Podcast** have teamed up to produce a series of podcast episodes featuring interviews with ESAB's filler metal experts.

On the first Friday of each month, Junkies host Jimmy McKnight and a group of ESAB application experts discuss common welding

issues during a 30 minute podcast segment called Filler Metal Friday. Topics cover a wide range of filler metal applications and issues while providing listeners with helpful insight to improve their skills.



Learn more at [esab.com/podcasts](http://esab.com/podcasts).



# THIS IS OUR PLEDGE.

We are committed to putting customers first. The **Iron Clad Pledge** is our promise to keep our customers' complete satisfaction at the forefront of everything we do. Our pledge is centered around:

- 100% Customer Satisfaction Program
- ESAB's extensive product warranties
- Customer-focused business practices

## 100% SATISFACTION PURCHASE PROTECTION.

We offer a 100% satisfaction guarantee on eligible products. If a customer is not happy within the first 100 days from purchase, we will make it right with a product replacement or complete refund. Should you need assistance, call 1-800-426-1888 and select Option 1 to be connected with a Customer Care representative. Count on ESAB to do whatever it takes to make it right for you.

## THE BEST PRODUCT WARRANTIES IN THE INDUSTRY.

ESAB is a global supplier to the welding and cutting industry. We are committed to providing our customers with reliable, high-quality products. To keep this commitment, we offer solid warranties across the entire ESAB family of brands, including:

- Arc equipment and accessories
- Cutting and gouging equipment
- Filler metals
- PPE

## LIFETIME WARRANTY ON EDGE™ 2.0 REGULATORS.

We have new and expanded warranties on many Victor® products, including a **LIFETIME Warranty** on all EDGE 2.0 regulators. Victor SR Series regulators – along with 100 and 300 Series torches and handles featured in our most popular outfits, such as Journeyman®, Journeyman Select, Performer® and Contender® – now have warranties extended **from 5 years to 10 years** on parts. Additionally, all Victor G Series regulators and 400 Series torches and handles, found in our Medalist® outfits, now have warranties extended **from 5 years to 7 years** on parts.

## CUSTOMER-FOCUSED BUSINESS PRACTICES.

ESAB has standard work processes designed to put customer needs as our top priority. Processes include:

- Voice-of-the-Customer that collects customer input early in the design process to ensure products meet or exceed customer needs.
- Support teams that execute robust, repeatable processes that consistently meet or exceed customer expectations.
- Responsive Customer Care representatives to aid customers with questions and to promote problem resolution.
- Dedication to a constant focus on quality and speed to continually earn our customers' business.

Learn more at [esab.com/ironclad](http://esab.com/ironclad).





100% SATISFACTION IS OUR **PROMISE TO YOU.**

**Our pledge:** To create the best products and give customers complete buying confidence with our 100% Satisfaction Guarantee and the most extensive warranties, including a new lifetime warranty on all Victor® EDGE™ Series 2.0 regulators.

Learn more at [esab.com/ironclad](https://www.esab.com/ironclad).

# // ARC WELDING EQUIPMENT







## CONTENTS

Arc Welding Processes .....	10
-----------------------------	----

### MIG MACHINES

Rebel™ EM 215ic & EM 235ic .....	13
Fabricator® 141i .....	14

### MULTI-PROCESS MACHINES

Rebel™ EMP 205ic AC/DC & EMP 215ic .....	15
Rebel™ EMP 235ic & EMP 285ic .....	16
Rebel™ Series Accessories .....	17
Warrior™ 300i CC/CV .....	18
Warrior™ 400i MV & Warrior 500i .....	19
Warrior™ 400i MV & 500i Accessories .....	21
Warrior™ 500i Multiple Operator Systems .....	22
Origo® Mig 4002c/5002cw/6502c .....	23
Aristo® Mig 4004i Pulse .....	25
Aristo® Mig 5000i/U5000i .....	26
Aristo® Mig 4004i Pulse & 5000i/U5000i Accessories .....	27

### WIRE FEEDERS

MobileFeed 201AVS & 301AVS .....	29
Warrior™ Feed 304 .....	30
Warrior™ Feed 404HD .....	30
Warrior™ Feed Dual 304 .....	31
Warrior™ YardFeed 200 .....	31
Ultrafeed 404HD .....	32
Origo® Feed 3004 MA23/MA24 .....	32
Aristo® Feed 3004 .....	33
Aristo® Feed 4004HD .....	33
Wire Feeder Control Panels .....	34
Aristo® U8 <sub>2</sub> Plus Controller .....	35
Aristo® SuperPulse™ .....	36
Wire Feeder Connection Cable Sets .....	37
Wire Feeder Accessories .....	38
MiniBoom Assembly .....	39
Balanced Boom Assembly .....	40

### STICK/TIG MACHINES

ES 95i .....	41
MiniArc 161LTS .....	42
ET 201i DC .....	43
Renegade™ ES 300i & ET 300iP .....	44
Renegade™ ES 300i & ET 300iP Accessories .....	45
ET 141i AC/DC .....	46
ET 186i AC/DC .....	47
ET 220i AC/DC .....	48
ET 301i AC/DC .....	49
ET 220i & 301i AC/DC Accessories .....	50
Heliarc® 281i & 353i AC/DC .....	51
Heliarc® 281i & 353i AC/DC Accessories .....	52

### MIG GUNS & TIG TORCHES

EASY FIND GUIDE - MIG Gun Selection Guide .....	53
Tweco Spray Master 250 Amp MIG Gun .....	55
Tweco Spray Master 350 Amp MIG Gun .....	55
Tweco Spray Master 450 Amp MIG Gun .....	56
Tweco Spray Master Velocity2 V250 Amp MIG Gun .....	56
Tweco Spray Master Velocity2 V350 Amp MIG Gun .....	57
Tweco Spray Master Velocity2 V450 Amp MIG Gun .....	57
Tweco Classic No. 1 180 Amp MIG Gun .....	58
Tweco Classic No. 2 200 Amp MIG Gun .....	58
Tweco Classic No. 3 300 Amp MIG Gun .....	59
Tweco Classic No. 4 400 Amp MIG Gun .....	59
Tweco Classic No. 5 500 Amp MIG Gun .....	60
Tweco Velocity2 Classic No. 1 180 Amp MIG Gun .....	60
Tweco Velocity2 Classic No. 2 200 Amp MIG Gun .....	61
Tweco Velocity2 Classic No. 3 300 Amp MIG Gun .....	61
Tweco Velocity2 Classic No. 4 400 Amp MIG Gun .....	62
Tweco Velocity2 Classic No. 5 500 Amp MIG Gun .....	62
Tweco Fusion 180 Amp MIG Gun .....	63
Tweco PulseMaster 450 Amp MIG Gun .....	63
Tweco Compact Eliminator 250 Amp MIG Gun .....	64
Tweco Compact Eliminator 450 Amp MIG Gun .....	64
Tweco Velocity2 Mini-MIG 160 Amp MIG Gun .....	65
Tweco Mini-MIG 160 Amp MIG Gun .....	65
Tweco Supra XT SEHD 400 Amp MIG Gun .....	66
Tweco Velocity2 Supra XT VSEHD 400 Amp MIG Gun .....	66
Tweco Smoke Master 250 Amp Fume Extraction Air-Cooled MIG Gun .....	67
Tweco Smoke Master 450 Amp Fume Extraction Air-Cooled MIG Gun .....	67
Tweco PullMaster 300 Amp MIG Gun .....	68
Tweco Flux-Cored SEFC 450 Amp MIG Gun .....	68
ESAB PPG 26 KD Air-Cooled Electric Push-Pull MIG Gun .....	70
ESAB PPW 401D Water-Cooled Electric Push-Pull MIG Gun .....	70
Tweco PulseMaster 400 Amp Water-Cooled MIG Gun .....	71
Tweco PulseMaster 500 Amp Water-Cooled MIG Gun .....	71
Tweco Standard 600 Amp Water-Cooled MIG Gun .....	72
ESAB ST Water-Cooled MIG Guns .....	72
Tweco Spool Guns .....	73
ESAB ST-23A Spool Gun .....	73
TXH GTAW Torches .....	74

### ARC ACCESSORIES

Remote Controls .....	75
Twist Lock Connectors .....	76
Interconnection Cables .....	76
Electrode Holders .....	77
Ground Clamps .....	78
Switchable Magnetic Work Holding Products .....	82
Cable Lugs .....	83
Cable Connectors .....	85
Splicers, Terminals and Accessories .....	86

## Arc Welding Processes

### Gas Metal Arc Welding (GMAW, MIG)



This most flexible metal joining process involves an arc established between the workpiece and a wire electrode, which is continuously fed by a wire feeder through a torch.

The arc continuously melts the electrode to form the weld puddle.

An appropriate gas or gas mixture shields the weld area from atmospheric contamination.

The GMAW process has the advantages of high deposition rates, speed, excellent weld quality, minimal distortion of the workpiece, and no stub loss.

GMAW applications include several distinct process variations. Selection depends largely on the workpiece thickness and welding position:

#### Short Circuiting (Short Arc, Dip Transfer)

Involves a small fast-freezing weld puddle. Metal is transferred from the electrode to the puddle by repeated short circuits. Small diameter wires are used and the process operates at low currents and voltages. Short arc is used for welding thin gauge metals in all positions and for vertical and overhead welding of heavier sections.

#### Spray Arc

Electrode metal is transferred to the weld puddle as discrete droplets. Deposition rate is high and there is little or no spatter. With solid wire, the technique is used for 1/8 in. (3.2 mm) and thicker workpieces and for downhand welding.

#### Pulsed Spray Arc

The welding current is varied rapidly between a high and a low value. Metal is transferred to the work only during the high current period. The high peak current provides excellent arc stability. The period of low current maintains the arc and reduces the average current, making it possible to weld thinner gauge materials and to weld in all positions using larger sized wire electrodes than otherwise possible.

#### Cored Wire (FCAW, MCAW)

The electrode is fabricated from strip, enclosing a core of flux and metal which protects and refines the weld puddle and controls bead shape. Some cored wires can be used without external shielding gas. Smaller diameter wires can be used for all position welding. The addition of fluxing, alloy and slag-forming materials often allows high deposition rates, higher welding speeds and improved all-position capability compared with solid wires. This makes cored wire the material of choice in many high-production applications.

### Shielded Metal Arc Welding (SMAW, Stick)



In this first practical arc welding process, the arc is established between a wire rod and the workpiece. The rod is coated with materials, which generate a gas and form a slag to protect the weld puddle and the solidifying weld metal from the atmosphere.

The coating may also supply alloying and refining ingredients,

and the slag may help shape the weld bead, especially in vertical and overhead applications.

Electrodes are available for welding most carbon, low alloy, and stainless steels, some non-ferrous metals, and a wide range of maintenance and repair applications.

Light-duty work is often done with AC power from low cost transformers; production work usually involves DC power from heavy-duty rectifiers.

### Gas Tungsten Arc Welding (GTAW, TIG)



Introduced by ESAB, the GTAW process produces welding heat from an arc between a non-consumable tungsten electrode and the workpiece. An inert gas, usually Argon, shields the arc and the workpiece.

Welding consumables, if used, are added separately. Because the process uses totally inert shielding

gas, welds of the highest quality are produced, and almost any metal can be welded.

### Additional Technical Information

ESAB Technical Service Representatives are available to answer your questions. We also recommend that you take advantage of a series of handbooks published by ESAB which provide excellent guidance on the use of the arc welding processes. In addition, there are references from other sources which can be very helpful in achieving the best possible results.

Call ESAB at 1.800.ESAB.123 to find out more.

# ALL-PROCESS AND INDUSTRIAL MACHINES JOIN THE EVER-GROWING REBELLION.

**REBEL**  
AC/DC

REBEL EMP 205ic AC/DC

REBEL EMP 215ic

REBEL EM 215ic



	REBEL 205ic AC/DC			REBEL 215ic
<b>Wire Range</b>	Full range of .030 solid wire Solid wire: .023-.045 Flux-Cored: .030-.045			Full range of .030 solid wire Solid wire: .023-.045 Flux-Cored: .030-.045
<b>Rated Output (amps @ duty cycle)</b>	<b>MIG</b> 110 A @ 100% 150 A @ 40% 205 A @ 25%	<b>STICK</b> 100 A @ 100% 125 A @ 60% 170 A @ 25%	<b>AC/DC TIG</b> 110 A @ 100% 125 A @ 60% 205 A @ 25%	110 A @ 100% 150 A @ 40% 205 A @ 25%
<b>Max Output</b>	<b>MIG/STICK</b> 235 A	<b>AC/DC TIG</b> 205 A		235 A
<b>Input Rating</b>	110 V-230 V (operating range 90 V-270 V)			110 V-230 V
<b>Max Plate Thickness</b>	24 ga., 3/8 in.			24 ga., 3/8 in.
<b>Spool Capable</b>	4 in., 8 in.			4 in., 8 in.
<b>Weight</b>	49 lb.			40 lb.
<b>Available Models and Processes</b>	<b>EMP 205ic AC/DC TRUE ALL-PROCESS</b> MIG, Flux-Cored, Stick, DC TIG, AC TIG HF			<b>EMP 215ic TRUE MULTI-PROCESS</b> MIG, Flux-Cored, Stick, DC TIG <b>EM 215ic</b> MIG, Flux-Cored

Coming soon, meet the world's first-ever portable all-process machine, Rebel EMP 205ic AC/DC, which runs every process like it was born to. And then there's the most industrial Rebel yet – Rebel EMP 285ic. New or not, every Rebel outperforms the competition and stands up to any challenge with a rugged multi-handle roll cage, steel unibody construction, and IP23S-level protection for outdoor use.

REBEL EMP 235ic

REBEL EM 235ic

REBEL EMP 285ic 1ph

REBEL EMP 285ic 3ph



NEED TO KNOW MORE? VISIT [ESAB.COM/REBEL](http://ESAB.COM/REBEL) TO LEARN ABOUT THE WHOLE REBEL FAMILY.

	REBEL 235ic	REBEL 285ic	
	Full range of .035 solid wire Solid wire: .023–.045 Flux-Cored: .030–.052v	Full range of .045 solid wire Solid wire: .023–.052 Flux-Cored: .030–.060	
	160 A @ 100% 200 A @ 60% 235 A @ 40%	<b>1ph unit</b> 160 A @ 100% 220 A @ 60% 285 A @ 40%	<b>3ph unit</b> 200 A @ 100% 265 A @ 60% 285 A @ 50%
	250 A	300 A (1ph) 350 A (3ph)	
	110 V–230 V	110 V–230 V (1ph) 460 V–575 V (3ph)	
	24 ga., 1/2 in.	24 ga., 1/2 in.	
	4 in., 8 in., 12 in.	4 in., 8 in., 12 in.	
	53 lb.	70 lb.	
	<b>EMP 235ic TRUE MULTI-PROCESS</b> <i>MIG, Flux-Cored, Stick, DC TIG</i> <b>EM 235ic</b> <i>MIG, Flux-Cored</i>	<b>EMP 285ic 1PH/3PH TRUE MULTI-PROCESS</b> <i>MIG, Flux-Cored, Stick, DC TIG v</i>	

## Rebel™ EM 215ic & EM 235ic Dual-voltage machine for MIG welding



[esab.com/rebel](http://esab.com/rebel)

MIG MACHINES

EM 215ic



EM 235ic



- Excellent performance for best-in-class MIG and Flux-Cored welding
- sMIG Technology - innovative “smart-MIG” feature that dynamically monitors the arc characteristics ultimately adapting to your technique resulting in a smooth, stable arc
- Set wire diameter and plate thickness and you are ready to weld
- Easy-to-read digital LED voltage/amperage display
- Rebel EM 215ic features a unique, industrial five-handle roll cage design and unibody steel construction in a lightweight, highly portable unit; 3-year handle-to-handle warranty
- Rebel Series models come ready-to-weld out of the box with Professional Grade TWECO accessories and Victor gas regulator; shielding gas not included
- Power to Perform – have the confidence with Rebel EM 235ic to run the full range of .035 in. (0.9 mm) wire – short arc and spray transfer even run .045 in. (1.2 mm) solid wire and some .052 in. (1.4 mm) flux cored wire

### Ordering Information

Rebel EM 215ic MIG Package	0558102436
Rebel EM 235ic Multi-Process Package	0558012700
Rebel EM 235ic Multi-Process Package with cart	0558012701

*Rebel EM 215ic packages includes Tweco Fusion 180A MIG gun, Victor flowmeter/regulator, 12.5 ft (3.8 m) gas hose, Tweco earth clamp, drive rolls, contact tips, sample of .030 in. (0.8 mm) MIG wire, 120V power adapter, and operator's manual.*

*Rebel EM 235ic packages includes Tweco Spraymaster 250A MIG gun, Victor flowmeter regulator, 12.5 ft (3.8 m) gas hose, Tweco earth clamp, drive rolls, contact tips, sample of .035 in. (0.9 mm) MIG wire, 120V power adapter, and operator's manual.*

### Specifications - Rebel EM 215ic

Input Voltage	Current Range	Supply Voltage Range	Wire Feed Speed	Rated kVA	MIG Voltage Range	Open Circuit Voltage
120 VAC, 208/230 VAC 1 ph, 50/60 Hz	5 – 150 A (120 V) 5 – 240 A (230 V)	90 – 270 VAC	80 – 476 ipm (1.5 – 12.1 m/min)	4.5 kVA (120 V) 7 kVA (230 V)	14.5 – 26 V	68 V
Welding Output		Wire Diameter		Maximum Output	Max Plate Thickness	
MIG (GMAW) 205 A/24.3 V (230 V) @ 25% Duty Cycle 130 A/20.5 V (120 V) @ 20% Duty Cycle		Mild Steel Stainless Aluminum Flux-Cored		235 A / 26V	3/8 in. (9.5 mm)	
Supply Plug	Lead Cord Length	Protection Class	Dimensions L x W x H		Weight	
230 V, NEMA 6-50P	6.5 ft (2 m)	IP23S	23 x 9 x 16 in. (584 x 229 x 406 mm)		40 lbs. (18.2 kg)	

### Specifications - Rebel EM 235ic

Input Voltage	Current Range	Wire Feed Speed	Rated kVA	MIG Voltage Range	Open Circuit Voltage
120 VAC, 208/230 VAC 1 ph, 50/60 Hz	5 – 150 A (120 V) 5 – 250 A (230 V)	60 – 700 ipm (1.5 – 18 m/min)	4.5 kVA (120 V) 7 kVA (230 V)	10 – 30 V	68 VDC
Welding Output		Wire Diameter		Maximum Output	Max Plate Thickness
MIG (GMAW) 235 A/26 V (230 V) @ 40% Duty Cycle 120 A/19 V (120 V) @ 40% Duty Cycle		Mild Steel Stainless Aluminum Flux-Cored		250 A / 30 V	1/2 in. (12.7 mm)
Supply Plug	Lead Cord Length	Protection Class	Dimensions L x W x H		Weight
230 V, NEMA 6-50P	10 ft. (3 m)	IP23S	26.5 x 11.5 x 19.5 in. (673 x 292 x 495 mm)		53 lbs. (24 kg)

# Fabricator<sup>®</sup> 141i

## Multi-process welding system



- Delivers 3-in-1 MIG, STICK, and TIG capability from one integrated, portable system
- Features digital meters, 4T trigger control and quick change polarity from the front of the power source
- Overload protection shuts down the power source to protect the internal electrical components from overheating
- Intelligent fan control operates when welding commences to cool components and reduce airborne contaminants pulled through the power source
- Infinite voltage control for precise voltage settings, inductance control for arc stability and spatter control, and adjustable burnback control
- Durable metal feed plate features 2-roll drive system, reversible drive rolls and easy-to-set single scaled wire tension knob
- Adjustable arc force control for optimum Stick (SMAW) electrode performance and built-in hot start for easy arc starting
- Lift TIG start provides TIG arc starting without the use of high frequency
- Spool-gun ready

MULTI-PROCESS MACHINES

### Specifications

Input Voltage	Current Range	Wire Feed Speed	Rated kVA	Supply Voltage Range	MIG Voltage Range	Open Circuit Voltage
120 VAC	10 – 140 A	90 – 390 ipm (2.3 – 9.9 m/min)	5 kVA @ 140 A	95 – 140 VAC	14.5 – 19 V	53 V
Welding Output					Wire Diameter	
MIG (GMAW) 140 A/19 V @ 15% Duty Cycle 90 A/18.5 V @ 20% Duty Cycle		TIG (GTAW) 140 A/15.6 V @ 15% Duty Cycle 100 A/14 V @ 20% Duty Cycle		Stick (SMAW) 90 A/23 V @ 15% Duty Cycle 80 A/23.2 V @ 35% Duty Cycle		Mild Steel .023 – .030 in. (0.6 – 0.8 mm) Stainless .023 – .030 in. (0.6 – 0.8 mm) Aluminum .030 in. (0.8 mm) Flux-Cored .030 – .035 in. (0.8 – 0.9 mm)
Maximum Output	Max Plate Thickness	Supply Plug	Lead Cord Length	Protection Class	Dimensions L x W x H	Weight
140 A	3/16 in. (4.8 mm)	NEMA 5-20P	10 ft. (3 m)	IP23S	16.2 x 8.3 x 17.7 in. (410 x 210 x 450 mm)	32.2 lbs. (14.6 kg)

### Ordering Information

Fabricator 141i Package	W1003141
Fabricator 141i Package with Cart	W1003142

*Includes power supply, flowgauge regulator and 12.5 ft. (3.8 m) hose, electrode holder with 13 ft. (4 m) lead, bonus contact tips (1 each) .023 in. (0.6 mm), .030 in. (0.8 mm) installed, .035 in. (0.9 mm), drive rolls .023/.030 in. (0.6/0.8 mm) V-groove installed, .030/.035 in. (0.8/0.9 mm) for flux cored wire, Tweco Fusion 140A MIG Gun with 10 ft. (3 m) cable, 4 general purpose stick electrodes (E6013), power adapter 115V, 20A to 15A, ground clamp with 10 ft. (3 m) lead, shoulder strap, operator's manual and CD, 10 ft. (3m) power cord and NEMA 5-20P 115V AC plug.*

### Options & Accessories

TIG Torch and Accessories (required for TIG welding)	W4013802
Tweco Spool Gun 160 A, 12 ft. (3.6 m) (required for AI MIG welding)	1027-1390
Ground Clamp and Lead Assembly, 10 ft. (3 m), 25 mm	W7003105
Electrode Holder and Lead Assembly, 13 ft. (4 m), 25 mm	W7003106
Dinse Adapter, 50 mm Female to 25 mm Male	W4017500
Victor GF250-50-580 Argon Flowgauge Regulator	0781-9411
Foot Control, 15 ft. (4.6 m) cable and 8-pin Male Plug	600285
Gas Hose, 12.5 ft. (3.8 m), Male 5/8-18UNF	W4013900
Power Adapter - 120 V, 20 A to 15 A	W4013300
Basic Utility Cart, max 7 in. (177.8 mm) diameter cylinder	W4014700
Drive Roll, V-Groove, .023/.030 in. (0.6/0.8 mm) (installed)	7977036
Drive Roll, Knurled V-Groove, .030/.035 in. (0.8/0.9 mm) (FCAW)	7977732

## Rebel™ EMP 205ic AC/DC & EMP 215ic Portable, true all-process welding system



[esab.com/rebel](http://esab.com/rebel)

EMP 205ic AC/DC



EMP 215ic



- True All-Process – excellent performance on MIG, Flux-Cored, Stick (including 6010 electrodes), DC TIG and AC TIG (EMP 205ic) industrial applications
- EMP 205ic AC/DC includes standard TIG features such as High Frequency starting, DC Pulse, AC Balance Adjustment, and AC Frequency Adjustment
- sMIG Technology - exclusive sMIG (“smart MIG”) feature continuously learns and adapts to the operator’s welding technique to provide a stable arc and superior, repeatable welds; increases productivity for the experienced welder, and reduces training time for novice welders
- Unique, five-handle roll cage industrial design and unibody steel construction in a lightweight, highly portable unit
- TFT Multilingual Display with 4 programmable memory locations for each process, trim adjustment, inductance control, pre/post flow control and spot weld setting
- Rebel Series models come ready-to-weld out of the box with Professional Grade TWECO accessories and Victor gas regulator

### Ordering Information

Rebel EMP 205ic AC/DC 10 ft. (3 m) System	0558102553
Rebel EMP 215ic Multi-Process MIG/TIG/Stick Package	0558102240

Rebel EMP 205ic AC/DC Package includes power supply, Tweco Fusion 180 Velocity MIG gun, electrode holder, Heliarc HW-17 TIG Torch outfit with accessory kit, foot control, .035 in. (0.9 mm) wire, Atom Arc 7018 electrodes. Victor argon flowmeter regulator, 12.5 ft. (3.8 m) hose, return clamp with leads, drive rolls and contact tips, and operator’s manual.

Rebel EMP 215ic AC/DC Package includes power supply, Tweco Fusion 180A MIG gun, Victor argon flowgauge regulator and 12.5 ft. (3.8 m) hose, Tweco earth clamp with leads, drive rolls and contact tips, sample .030 in. (0.8 mm) wire, Tweco electrode holder and sample electrodes, 17V Style TIG torch, power adapter and operator’s manual.

### Rebel EMP 205ic AC/DC Specifications

Input Voltage	Input Current Draw	Current Range	Wire Feed Speed	Rated kVA	MIG Voltage Range	
120/230 VAC 1 ph +/- 10%, 50/60 Hz	30 A (27.6 A) @ 25% Duty Cycle	5 – 235 A	80 – 475 ipm (2.0 – 12.0 m/min)	4.98 kVA (> 7 kVA generator)	12 – 26 V	
Welding Output				AC TIG Functionality	DC Pulse	
MIG (GMAW) 205 A/24.3 V @ 25% Duty Cycle 150 A/21.5 V @ 40% Duty Cycle 125 A/20.3 V @ 60% Duty Cycle 110 A/19.5 V @ 100% Duty Cycle	TIG (GTAW) 205 A/18.2 V @ 25% Duty Cycle 125 A/15.0 V @ 60% Duty Cycle 110 A/14.4 V @ 100% Duty Cycle	Stick (SMAW) 170 A/27.2 V @ 25% Duty Cycle 125 A/25.0 V @ 60% Duty Cycle 100 A/24.0 V @ 100% Duty Cycle	Balance Range Frequency Range	1 – 99% 25 – 400 Hz	1 – 500 p/s	
Open Circuit Voltage	Power Factor @ Max Current	Efficiency @ Max Current	Lead Cord Length	Protection Class	Dimensions L x W x H	Weight
68 V	0.98	83%	6 ft. (1.8 m)	IP23	23 x 9 x 16 in. (584 x 229 x 406 mm)	49 lbs. (22 kg)

### Rebel EMP 215ic Specifications

Input Voltage	Current Range	Supply Voltage Range	Wire Feed Speed	Rated kVA	MIG Voltage Range	Open Circuit Voltage
120 VAC, 208/230 VAC 1 ph, 50/60 Hz	5 – 150 A (120 V) 5 – 240 A (230 V)	90 – 270 VAC	59 – 476 ipm (1.5 – 12.1 m/min)	4.5 kVA (120 V) 7 kVA (230 V)	10 – 26 V	68 V
Welding Output					Wire Diameter	
MIG (GMAW) 130 A/20.5 V (120 V) @ 20% Duty Cycle 205 A/24.3 V (230 V) @ 25% Duty Cycle	TIG (GTAW) 130 A/15.2 V (120 V) @ 40% Duty Cycle 180 A/17.2 V (230 V) @ 30% Duty Cycle	Stick (SMAW) 90 A/23.6 V (120 V) @ 40% Duty Cycle 180 A/27.2 V (230 V) @ 25% Duty Cycle	Mild Steel Stainless Aluminum Flux-Cored	.023 – .035 in. (0.6 – 0.9 mm) .030 – .035 in. (0.8 – 0.9 mm) .030 – .045 in. (0.8 – 1.2 mm) .030 – .045 in. (0.8 – 1.2 mm)		
Maximum Output	Max Plate Thickness	Supply Plug	Protection Class	Dimensions L x W x H	Weight	
235 A / 26 V	3/8 in. (9.5 mm)	230 V, NEMA 6-50P	IP23S	23 x 9 x 16 in. (584 x 229 x 406 mm)	40 lbs. (18.2 kg)	

MULTI-PROCESS MACHINES



# Rebel™ EMP 235ic & EMP 285ic

## Industrial, multi-process packages



[esab.com/rebel](http://esab.com/rebel)

EMP 235ic



EMP 285ic shown with optional cart



- True Multi-Process – excellent performance on MIG, TIG and STICK
- Unmatched Portability – weighing in at 53 lbs. (24 kg) with dual voltage capability and 4 handle roll cage
- Power to Perform – have the confidence to run the full range of .035 in. (0.9 mm) wire – short arc and spray transfer
- Run solid wire up to .045 in. (1.2 mm) and cored wire up to .052 in. (1.4 mm), plus stick electrodes up to 5/32 in. (4.0 mm) and TIG rods up to 3/16 in. (5.0 mm)
- sMIG Technology – innovative “smart-MIG” feature that dynamically monitors the arc characteristics ultimately adapting to your technique resulting in a smooth, stable arc

MULTI-PROCESS MACHINES

### Ordering Information

Rebel EMP 235ic Multi-Process Package	0558012702
Rebel EMP 235ic Multi-Process Package with cart	0558012704
Rebel EMP 285ic 120 V – 230 V, 1 ph System	0558102554
Rebel EMP 285ic 460 V – 575 V, 3 ph System	0558102556
Rebel EMP 285ic 120 V – 230 V, 1 ph System with Cart	0558012704
Rebel EMP 285ic 460 V – 575 V, 3 ph System with Cart	0558102557

Rebel EMP 235ic Package includes power supply, Tweco SprayMaster 250 MIG gun, Victor argon flowmeter regulator, 12.5 ft. (3.8 m) hose, return clamp with leads, drive rolls and contact tips, .035 in. (0.9 mm) wire, electrode holder and Atom Arc 7018 electrodes, power adapter, and operator's manual. Cart packages include single cylinder cart.

Rebel EMP 285 Packages includes power supply, Tweco Spray Master Velocity V250 MIG gun, electrode holder, Atom Arc 7018 electrodes, Victor argon flowmeter regulator, 12.5 ft. (3.8 m) hose, return clamp with leads, drive rolls and contact tips, .035 in. (0.9 mm) wire and operator's manual. Cart packages include single cylinder cart.

### Rebel EMP 235ic Specifications

Input Voltage	Current Range	Wire Feed Speed	Rated kVA	MIG Voltage Range	Open Circuit Voltage	
120 VAC, 208/230 VAC 1 ph, 50/60 Hz	5 – 150 A (120 V) 5 – 250 A (230 V)	60 – 700 ipm (1.5 – 18 m/min)	4.5 kVA (120 V) 7 kVA (230 V)	10 – 30 V	68 VDC	
Welding Output				Wire Diameter		
MIG (GMAW) 120 A/19 V (120 V) @ 40% Duty Cycle 235 A/26 V (230 V) @ 40% Duty Cycle	TIG (GTAW) 130 A/15.2 V (120 V) @ 40% Duty Cycle 240 A/19.6 V (230 V) @ 40% Duty Cycle	Stick (SMAW) 90 A/23.6 V (120 V) @ 40% Duty Cycle 210 A/28.4 V (230 V) @ 25% Duty Cycle	Mild Steel Stainless Aluminum/FCAW	.023 – .035 in. (0.6 – 0.9 mm) .030 – .035 in. (0.8 – 0.9 mm) .030 – .045 in. (0.8 – 1.2 mm)		
Maximum Output	Max Plate Thickness	Supply Plug	Lead Cord Length	Protection Class	Dimensions L x W x H	Weight
250 A/30 V	1/2 in. (12.7 mm)	230 V, NEMA 6-50P	10 ft. (3 m)	IP23S	26.5 x 11.5 x 19.5 in. (673 x 292 x 495 mm)	53 lbs. (24 kg)

### Rebel EMP 285ic Specifications

Input Voltage	Current Range	Wire Feed Speed	Supply Voltage Range	MIG Voltage Range	Open Circuit Voltage	
120 – 240 VAC 1 ph, 50/60 Hz 460 – 575 VAC 3 ph, 50/60 Hz	5 – 300 A (1 ph) 5 – 350 A (3 ph)	60 – 800 ipm (1.5 – 20.3 m/min)	90 – 270 VAC	12 – 34 V	68 VDC	
Welding Output				Wire Diameter		
MIG (GMAW) 285 A/28 V @ 40% Duty Cycle (1 ph) 220 A/25 V @ 60% Duty Cycle (1 ph) 160 A/22 V @ 100% Duty Cycle (1 ph) 285 A/28 V @ 50% Duty Cycle (3 ph) 265 A/27 V @ 60% Duty Cycle (3 ph) 200 A/24 V @ 100% Duty Cycle (3 ph)	TIG (GTAW) 285 A/21 V @ 40% Duty Cycle (1 ph) 240 A/19 V @ 60% Duty Cycle (1 ph) 185 A/17 V @ 100% Duty Cycle (1 ph) 285 A/21 V @ 50% Duty Cycle (3 ph) 265 A/21 V @ 60% Duty Cycle (3 ph) 220 A/19 V @ 100% Duty Cycle (3 ph)	Stick (SMAW) 260 A/30 V @ 40% Duty Cycle (1 ph) 210 A/28 V @ 60% Duty Cycle (1 ph) 135 A/25 V @ 100% Duty Cycle (1 ph) 285 A/31 V @ 50% Duty Cycle (3 ph) 255 A/30 V @ 60% Duty Cycle (3 ph) 180 A/27 V @ 100% Duty Cycle (3 ph)	Mild Steel Stainless Aluminum Flux-Cored	.023 – .052 in. (0.6 – 1.3 mm) .030 – .052 in. (0.8 – 1.3 mm) .030 – 1/16 in. (0.8 - 1.6 mm) .030 – 1/16 in. (0.8 - 1.6 mm)		
Maximum Output	Max Plate Thickness	Supply Plug	Lead Cord Length	Protection Class	Dimensions L x W x H	Weight
300 A/34 V (1 ph) 350 A/34 V (3 ph)	1/2 in. (12.7 mm)	NEMA 6-50P (230 V), no plug for 3 ph unit	10 ft. (3 m)	IP23S	26.5 x 11.5 x 19.5 in. (673 x 292 x 495 mm)	70 lbs. (32 kg)

## Rebel™ Series Accessories

Options & Accessories		EM 215ic	EM 235ic	EMP 205ic AC/DC EMP 215ic	EMP 235ic	EMP 285ic
W4014603	TIG Torch 26 V & Accessories			■	■	■
W4013802	TIG Torch 17 V & Accessories, 13 ft (4 m) 25/50mm Dinse			■	■	■
0558102493	ESAB TXH 201 5/8 npt 12.5 ft (3.8 m) TIG Torch Outfit				■	■
10271397	Tweco Spool Gun 160 A, 12 ft (3.6 m)	■		■		
10271398	Tweco 200A 12 ft (3.6 m) Spool Gun		■		■	■
10271399	Tweco 200A 25 ft (7.6 m) Spool Gun		■		■	
WS200E13	Electrode Holder 200 A & Lead Assembly, 13 ft (4m), 50mm			■		■
91101131	Tweco T532 Electrode Holder				■	
91101132	Tweco T316 Electrode Holder					■
0781-9411	Victor Argon Flow Regulator GF-250-50-580	■		■		
0781-2743	Victor HRF 1400 Argon Flowmeter Regulator	■	■		■	■
W4013900	Gas Hose, 12.5 ft (3.8 m), Male 5/8-18UNF	■		■	■	
W4014450	Foot Control, 15 ft (4.6 m) cable & 8-pin Male Plug			■	■	■
W4014000	Power Adaptor, 230 V to 120 V, 15 A	■		■	■	■
0558102325	Rebel Utility Cart, max 7 in. (177.8 mm) diameter cylinder	■		■		
W4015001	Single Cylinder Cart, max 9 in. (228.6 mm)	■		■		
0558102491	Rebel Single Cylinder Cart	■	■	■	■	■
10231277	Tweco SprayMaster VELOCITY2 V250 15 ft (4.6 m)				■	■
10361756	Tweco SprayMaster VELOCITY2 V350 15 ft (4.6 m)					■

MULTI-PROCESS MACHINES



# Warrior™ 300i CC/CV

Multi-process inverter power source



[esab.com/warrior](http://esab.com/warrior)



- Leading MiCOR Inverter Technology enables use of longer primary cables, reduces power consumption by up to 25% and reduces weight and size while delivering exceptional welding performance in all processes
- Adjustable inductance control for arc stability and spatter control plus optimized selection modes for CO<sub>2</sub> and mixed gases for MIG welding
- Adjustable hot start control, adjustable arc force control and optimized selection modes for E6010 vertical-up, vertical-down and E7018 electrodes for optimum Stick welding
- Lift TIG start provides TIG arc starting without the use of high frequency
- Special arc gouging mode for optimum air carbon arc gouging
- Weighs less than 54 lbs. (24.5 kg), ideal for on-site and portable welding applications
- For use with UltraFeed 404HD, MobileFeed 201AVS or 301AVS wire feeders
- Suitable for use with other standard OEM wire feeders

MULTI-PROCESS MACHINES

## Specifications

Input Voltage	Current Range	Rated kVA	Supply Voltage Range	Input Current	Open Circuit Voltage
208-230/400/460 VAC 1/3 ph, 50/60 Hz	10 – 300 A (1 ph) 10 – 400 A (3 ph)	14.4 kVa @ 400 A	177-529 VAC	53.2 A (280 V/3 ph) 49.1 A (230 V/3ph) 28.6 A (460 V/3ph)	80 VDC
Welding Output					
MIG (GMAW) @ 104°F (40°C) 300 A/29 V @ 25% Duty Cycle, 1 ph 230 A/25.5 V @ 60% Duty Cycle, 1 ph 180 A/23 V @ 100% Duty Cycle, 1 ph 400 A/34 V @ 25% Duty Cycle, 3 ph 300 A/29 V @ 60% Duty Cycle, 3 ph 220 A/25 V @ 100% Duty Cycle, 3 ph		TIG (GTAW) @ 104°F (40°C) 300 A/22 V @ 25% Duty Cycle, 1 ph 230 A/19.2 V @ 60% Duty Cycle, 1 ph 180 A/17.2 V @ 100% Duty Cycle, 1 ph 400 A/26 V @ 25% Duty Cycle, 3 ph 300 A/22 V @ 60% Duty Cycle, 3 ph 220 A/18.8 V @ 100% Duty Cycle, 3 ph		Stick (SMAW) @ 104°F (40°C) 300 A/32 V @ 22% Duty Cycle, 1 ph 230 A/29.2 V @ 60% Duty Cycle, 1 ph 180 A/27.2 V @ 100% Duty Cycle, 1 ph 300 A/32 V @ 60% Duty Cycle, 3 ph 220 A/28.8 V @ 100% Duty Cycle, 3 ph	
Maximum Output	Protection Class	Dimensions L x W x H		Weight	
400 A	IP23S	17.7 x 8.3 x 16.5 in. (450 x 210 x 420 mm)		54 lbs. (24.5 kg)	

## Ordering Information (not for sale in Canada)

Warrior 300i Power Source	0558102558	Warrior 300i/Ultrafeed 4HD Wire Feeder MIG Package	0558102559
---------------------------	------------	--	------------

Warrior 300i Power Source includes 10 ft. (3 m) input lead, two male Dinse connectors 50 mm and operator's manual.  
Warrior 300i MIG Package includes Ultrafeed 4HD wire feeder, interconnection and power cable, 15 ft. (4.6 m) Spray Master 450 MIG gun, ground clamp with 10 ft. (3 m) lead, Victor ESS3-FG-580 argon flowgauge regulator, 12.5 ft. (3.8 m) gas hose, industrial cart and everything included with the power source package (W1009500).

## Options & Accessories

Ultrafeed 4HD Wire Feeder	0558102560	Gas Hose	W4013900
MobileFeed 201AVS with Meters, Tweco Style	0558102206	Foot Control, 15 ft. (4.6 m)	10-2008
MobileFeed 201AVS with Meters remote, voltage Tweco style	0558101911	Foot Control, 25 ft. (7.6 m)	10-2007
MobileFeed 301AVS with Meters, Tweco Style	0558102195	Hand Held Pendant	10-2005
MobileFeed 301AVS with Meters, Remote Voltage, Tweco Style	0558101919	TIG Torch Switch Control, 25 ft. 7.6 m, 14 Pin - On/Off	10-2001
Control Cable, 6 ft. (1.8 m)	374878-006	TIG Torch Switch Control, 25 ft. 7.6 m, 14 Pin - On/Off, Current Control, CK9	10-2002
Control Cable, 15 ft. (4.6 m)	374878-015	TIG Torch Switch Control, 25 ft. 7.6 m, 14 Pin - On/Off, Current Control, CK17	10-2003
Control Cable, 25 ft. (7.6 m)	374878-025	TIG Torch Switch Control, 25 ft. 7.6 m, 14 Pin - On/Off, Current Control, CK26	10-2004
Control Cable, 50 ft. (15.2 m)	374878-050	Dinse Connector	9425-1431
Control Cable, 100 ft. (30.4 m)	374878-100	Industrial Cart	W4010004
TIG Torch Kit	10-4080	Power Cable, 6 ft. (1.8 m), 50 mm Maie - 50 mm Female	W4015850
Tweco Electrode Holder	9110-1177	K3000 Arc Gouging Torch, 600A, 7 ft. (2.1 m), 80 psi	6106-5006
Tweco 300A Ground Clamp	W4009301	Dust Filter	W7006715
Victor Flowgauge Regulator	0781-5120		

## Warrior™ 400i MV & Warrior 500i Powerful, multi-process welder



[esab.com/warrior](http://esab.com/warrior)



Warrior 400i MV



Warrior 500i shown with cooling unit and trolley

MULTI-PROCESS MACHINES

- Warrior™ is a reliable multi-process welding machine designed for heavy-duty productivity with up to 500 Amps delivered with superb arc characteristics
- Inverter Technology – outstanding arc performance and energy savings expected from an inverter along with increased energy efficiency and more power from a lighter, smaller, and more portable unit
- High-Duty Cycle – for long runs across a variety of applications
- Durable and rugged – IP23 rating for outdoor and indoor use in rough environments along with handles built into frame for crane lifting
- Easy-to-use – clear and intuitive user interface to get started quickly with glove-friendly knobs for quick and easy adjustments
- Warrior 400i MV provides auto sense from 208-460V 3ph
- Parallel Kit available for Warrior 500i for extreme manual gouging operations with Arcair® AirPro™ X4000 torch – contact ESAB for more information
- RTW packages include everything needed for a mobile welding package (404HD & DualFeed 304 packages include 2-cyl cart)
- Basic Packages do not include connection cable set or cylinder cart – buy a package system and choose length of connection cable set you need (sets include control cable, welding cable, gas hose) and any accessories of your choice

Specifications		Warrior 400i MV	Warrior 500i
Input voltage		220/460 V, 3ph, 60Hz +/- 10%	460/575 V, 3ph, 60Hz +/- 10%
Permitted load at:		400/34 V @ 60% duty cycle 300A/30 V @ 100% duty cycle	500A/39 V @ 60% duty cycle 400A/34 V @ 100% duty cycle
Mains voltage primary current at:		220/460 V, 3ph, 44/22 A	460/575 V, 28/24 A
Settings range DC	GMAW FCAW SMAW GTAW	16-400 A/8-34 V 5-400 A/8-36 V	16-500 A/15-40 V 5-500 A/10-30 V
Open circuit voltage		56 V peak (without VRD activated) 28 V peak (with VRD activated)	84 V peak (without VRD activated) 28 V peak (with VRD activated)
Energy Saving mode (6.5min after welding)		50 W	40 W
Power factor at maximum current		0.95	0.87
Efficiency at maximum current		85%	90%
Control voltage		42 V, 50/60 Hz	42 V, 50/60 Hz
Operating temperature		14 – 104°F (-10 – 40°C)	14 – 104°F (-10 – 40°C)
Enclosure class		IP 23	IP 23
Application class		S	S
Dimensions, L x W x H, in. (mm)		28.1 x 12.8 x 18.5 in. (712 x 325 x 470 mm)	28.1 x 12.8 x 18.5 in. (712 x 325 x 470 mm)
Weight, lbs (kg)		115 lbs. (52 kg)	115 lbs. (52 kg)

Recommended Parameters for Manual Air Carbon Arc Gouging			
Electrode	Voltage Min	Voltage Max	Electrode Extension
1/4 in. (6.0 mm)	36 V	49 V	2-3 in. (50-76 mm)
5/16 in. (8.0 mm)	39 V	52 V	
3/8 in. (9.5 mm)	43 V	52 V	
1/2 in. (12.7 mm)	48 V (500i in parallel)	54 V (500i in parallel)	

# Warrior™ 400i MV & Warrior 500i

## Warrior 400i MV - Ordering Information

Warrior 400i MV CC/CV, 220-460 V, 3 ph, Power Source Only	0465885880	Warrior 400i MV WF 304, SM V350 Gun Basic Package*	0558102270
Warrior 400i MV WF 304 6.5 ft. (1.7 m), SM V350 Gun, RTW	0558102271	Warrior 400i MV WF 404HD, SM V350 Basic Package*	0558102278
Warrior 400i MV WF 404HD 6.5 ft. (1.7 m), SM V350, RTW	0558102281	Warrior 400i MV WF Dual 304, SM V350 Basic Package*	0558102462
Warrior 400i MV WF Dual 304 6.5 ft. (1.7 m), SM V350, RTW	0558102463	Warrior 400i MV MobileFeed 201AVS, SM V350 Gun Package	0558102274
		Warrior 400i MV MobileFeed 301AVS, SM V350 Gun Package	0558102273

Warrior 400i MV RTW (Ready To Weld) packages include: wire feeder with .035-.045 V-groove feedrolls, 5.5 ft or 32 ft Connection set, V350 15 ft torches, 15' or 32' work cable with clamp, and regulator/flowmeter. Mig Racers include HD Cart.

## Warrior 500i - Ordering Information

### USA

Warrior 500i 380/460/575 V, 3 ph, Power Source Only	0465350881	Warrior 500i WF 304 SM V350 15' Basic Package	0558101759
Warrior 500i WF 304 6.5 ft. (2 m), SM V350 Gun 15', RTW	0558101760	Warrior 500i WF 404HD SM V350 15' Basic Package	0558102282
Warrior 500i WF 404HD 6.5 ft. (2 m), SM V350 Gun 15', RTW	0558102283	Warrior 500i WF DUAL 304 SM V350 15' Basic Package	0558102464
Warrior 500i WF DUAL 304 6.5ft (2m), SM V350 Gun 15', RTW	0558102465	Warrior 500i MobileFeed 201AVS, SM V350 Gun Package	0558102391
		Warrior 500i MobileFeed 301AVS, SM V350 Gun Package	0558101762

### Canada







Warrior 500i 380/460/575 V, 3 ph, Power Source Only	0465350887	Warrior 500i WF 304 SM V350 15' Basic Package*	0561000160
Warrior 500i WF 304 6.5 ft. (2 m), SM V350 Gun 15', RTW	0561000155	Warrior 500i WF 404HD SM V350 15' Basic Package*	0561000161
Warrior 500i WF 404HD 6.5 ft. (2 m), SM V350 Gun, RTW	0561000156	Warrior 500i WF DUAL 304 SM V350 15' Basic Package*	0561000162
Warrior 500i WF DUAL 304 6.5ft (2m), SM V350 Gun, RTW	0561000157	Warrior 500i WF MobileFeed 301AVS SM V350 15'	0558101762

Warrior 500i RTW - Ready-to-Weld packages include power source, wire feeder, connection set, regulator/flowmeter, .035/.045 in. (0.9-1.2 mm) feed rolls and 1-cylinder cart.

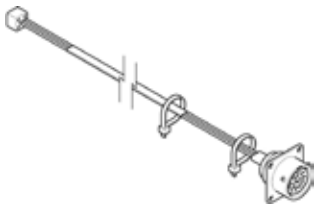
Basic packages require gun, connection cable set to be ordered separately.

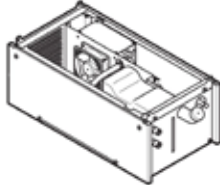
Warrior 500i packages for US come set at 460V.

Warrior 500i packages for Canada come set at 575V

 <p><b>Remote Outlet Kit*</b> Part Number: 0465424880</p>	 <p><b>Wheel Kit</b> Part Number: 0465427880</p>	 <p><b>Cooling Unit</b> Part Number: 0465427880</p>	 <p><b>Foot Control FS002</b> Part Number: 0349030886 Requires Remote Outlet Kit</p>
 <p><b>Warrior Trolley</b> Part Number: 0465510880 Use with Warrior Feed 304 only</p>		 <p><b>HD Trolley</b> Part Number: 0558102236 (0558102310 WarriorBracket – order if Trolley purchased separately) (0349303362 Cable Holder Kit – order 2 for HD cart)</p>	

MULTI-PROCESS MACHINES

## Warrior™ 400i MV & 500i Accessories

Options & Accessories	
Warrior Feed 304 Air-Cooled	0465250880
Warrior Feed 304w Water-Cooled	0465250881
Warrior Feed 404HD (Tweco Connection)	0558102235
Warrior Feed Dual 304 (Euro Connection)	0558101946
Warrior Feed Dual 304 (Tweco Connection)	0558101947
Warrior YardFeed 200 Air-Cooled	0459906900
Warrior YardFeed 200w Water-Cooled	0459906901
MobileFeed 201AVS w/meter (Euro Connection)	0558101910
MobileFeed 201AVS w/meter (Tweco Connection)	0558102194
MobileFeed 301AVS w/meter (Tweco Connection)	0558102195
Tweco Spray Master V250 MIG Gun (Euro), up to .045 in. (1.2 mm), 15 ft. (4.6 m)	1023-1288
Tweco Spray Master V350 MIG Gun (Tweco), up to 1/16 in. (1.6 mm), 15 ft. (4.6 m)	1036-1756
Tweco Spray Master V450 MIG Gun (Euro), up to 1/16 in. (1.6 mm), 15 ft. (4.6 m)	1040-1850
Victor EDGE ESS3-40-580 Ar Single-Stage Regulator/Flowmeter	0781-5120
MiniBoom Counterbalance Device (Requires Bracket kit 0461310880)	0458705880
Stabilizer kit for Counterbalance Arm	0465509880
Remote Adapter Kit Miggytrac/Railtrac	0465451881
Remote Adapter Kit Miggytrac/Railtrac	0465451881
Remote Cable AN 8-12 Pole 16.4 ft. (5 m)	0459552880
Remote Cable AN 8-12 Pole 32.8 ft. (10 m)	0459552881
Remote Cable AN 8-12 Pole 49.2 ft. (15 m)	0459552882
Remote Cable AN 8-12 Pole 82 ft. (25 m)	0459552883
Remote control AT1	0459491896
Remote control AT1 CoarseFine	0459491897
Remote control M1	0459491895
Remote Outlet Kit for Power Source	0465424880
COOL 2 Water Cooler	0465427880
Female gas hose quick-connector	0365803002
Gas Meter (measures gas flow at the gun)	19043
Guide pin extension kit, feeder	0465508880
Trolley - 4-wheel, 1-cylinder	0465510880
Heavy-Duty Cart, 2-cylinder	0558102236
Swivel Post for Heavy-Duty Cart (Warrior Feed only)	34075
Bracket Kit for Heavy-Duty Cart (0558102236)	0558102310
Wheel kit, power source	0465416880

# Warrior™ 500i Multiple Operator Systems

## 4 & 6 Packs

[esab.com/warrior](http://esab.com/warrior)



- These rack systems feature a rugged design with heavy-duty frame and roof, easily lifted by crane or forklift
- Warrior 500i power sources are reliable, multi-process welding machines designed for heavy-duty productivity with up to 500 Amps delivered with superb arc characteristics
- Choose from 4 or 6-pack racks to get the power you need in one convenient package
- The Multiple Operator Rack Systems are also available for Warrior 300i and Warrior 400i MV machines as well as Aristo Mig 4004i Pulse and Aristo Mig 5000i and Renegade ES 300i machines - contact ESAB for further details
- Easy maintenance with less components
- Hardwired components
- Convenient and reliable circuit breakers, no fuses to replace
- Electrical panel is easy to assemble with high safety standards
- Racks can be ordered alone for existing compatible machines

MULTI-PROCESS MACHINES

### Specifications

Dimensions L x W x H	Weight - 4 Pack Rack Warrior 500i	Weight - 6 Pack Rack Warrior 500i
42.2 x 37.5 x 60.5 in. (1071 x 953 x 1537 mm)	1000 lbs. (453.5 kg) with machines 530 lbs. (240.4 kg) without machines	1300 lbs. (589.7 kg) with machines 550 lbs. (249.5 kg) without machines

### Ordering Information

#### Warrior 500i Multiple Operator System Packages

Warrior 500i cvcc 460V 4 Pack Rack	0588002034
Warrior 500i cvcc 460V 6 Pack Rack	0588002036
Warrior 500i cvcc 575V 4 Pack Rack	0588002234
Warrior 500i cvcc 575V 6 Pack Rack	0588002236

#### Rack Only

4-Pack Rack	0588002232
6-Pack Rack	0588002233

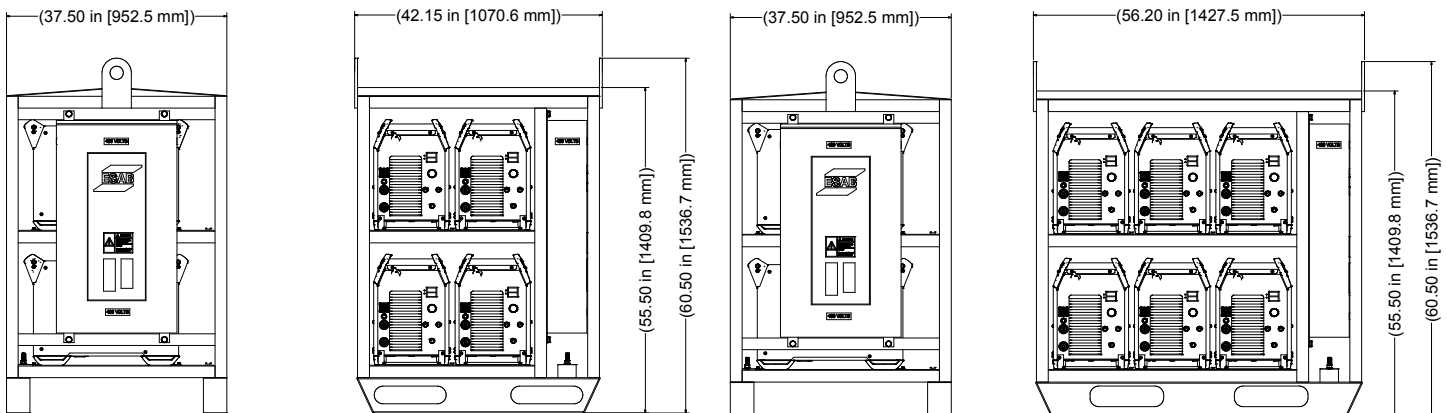

## Origo® Mig 4002c/5002cw/6502c Advanced Synergic Multi-Process System



[esab.com/weldcloud](http://esab.com/weldcloud)

WeldCloud



- The multi-process Origo® Mig power sources provide substantially improved arc welding performance and higher productivity for robotic and semi-automatic applications
- Origo Mig multi-voltage (230/460/575 V, 3 ph) power sources operate with all Origo Feed and Aristo® Feed wire feeders
- Platform allows for use with simple welding operations to advanced synergic systems – eliminating need for power source specific applications
- Large wheels, sturdy lifting eyelets, and undercarriage make the unit easy to move around
- Origo Mig 4002c, 5002cw, and 6502c are sturdy and robust switching converter (chopper) power sources intended for heavy-duty applications, with the energy efficiency of an inverter
- Auxiliary 115 VAC standard on select models (USA only)
- Modular design allows control panel to be moved to power source when feeder is out of reach or being subjected to harsh operations

Specifications		4002c	5002cw	6502c
Input Voltage	USA Canada	230/460V, 3ph, 60Hz 230/460/575V, 3ph, 60Hz	- 230/460/575V, 3ph, 60Hz	230/460V, 3ph, 60Hz 230/460/575V, 3ph, 60Hz
Permitted load at:		400 A/34 V @ 60% duty cycle 310 A/30 V @ 100% duty cycle	500 A/39 V @ 60% duty cycle 400 A/34 V @ 100% duty cycle	650 A/44 V @ 60% duty cycle 500 A/39 V @ 100% duty cycle
Mains voltage Primary current at:	60% duty cycle 100% duty cycle	230/460/575 V 55/29(43)/22 A 43/25/20 A	230/460/575 V 75/39(50)/30 A 58/39/23 A	230/460/575 V 103/54(59)/52 A 80/50(63)/33 A
Settings range DC	GMAW/FCAW SMAW/GTAW	16-400 A/8-34 V 16-400 A/8-36 V	16-500 A/8-39 V 16-500 A/8-40 V	16-650 A/8-44 V 16-650 A/8-44 V
Open circuit voltage	GMAW/FCAW SMAW/GTAW	70 V 61 V	70 V 61 V	70 V 61 V
Open circuit power		500 W	550 W	670 W
Energy saving mode (15 mins after welding)		60 W	60 W	60 W
Power factor at maximum current		0.88	0.90	0.90
Efficiency at maximum current		70%	72%	76%
Control voltage		42 V, 50/60 Hz	42 V, 50/60 Hz	42 V, 50/60 Hz
Operating temperature		14 – 104°F (-10 – 40°C)	14 – 104°F (-10 – 40°C)	14 – 104°F (-10 – 40°C)
Enclosure class		IP 23	IP 23	IP 23
Dimensions, L x W x H, in. (mm)		32.6 x 25 x 32.8 in. (830 x 640 x 835 mm)	32.6 x 25 x 32.8 in. (830 x 640 x 835 mm)	32.6 x 25 x 32.8 in. (830 x 640 x 835 mm)
Weight, lbs (kg)		328 lbs. (149 kg)	407 lbs (185 kg) 438 lbs. (198 kg) with cooling unit	489 lbs. (222 kg)

### Origo Mig 4002c - Ordering Information - USA

USA			
Origo MIG 4002c CVCC, 230/460 V, 3 ph, 60 Hz Power Source*	0349312390	Origo MIG 4002cw CVCC, 230/460 V, 3 ph, 60 Hz Power Source	0349311320
Origo MIG 4002c/Origo Feed 3004 MA23 Ready-to-Weld Package	0558101332	Origo MIG 4002c/Origo Feed 3004 MA23 Basic Package	0558101333
Origo MIG 4002c/Origo Feed 3004 MA24 Ready-to-Weld Package	0558101338	Origo MIG 4002c/Origo Feed 3004 MA24 Basic Package	0558101339
Origo MIG 4002c/Aristo Feed 3004 U6 Ready-to-Weld Package	0558101344	Origo MIG 4002c/Aristo Feed 3004 U6 Basic Package	0558101345
Origo MIG 4002c/Aristo Feed 3004 U8 <sub>2</sub> Plus Ready-to-Weld Package	0558101354	Origo MIG 4002c/Aristo Feed 3004 U8 <sub>2</sub> Plus Basic Package	0558101355

\*Includes 115 VAC, 10 A outlet.

Canada			
Origo MIG 4002c CVCC, 230/460/575 V, 3 ph, 60 Hz Power Source	0349311780	Origo MIG 4002c/Origo Feed 3004 MA23 Ready-to-Weld Package	0561000060
Origo MIG 4002c/Origo Feed 3004 MA23 Basic Package	0561000061	Origo MIG 4002c/Origo Feed 3004 MA24 Ready-to-Weld Package	0561000062
Origo MIG 4002c/Origo Feed 3004 MA24 Basic Package	0561000063	Origo MIG 4002c/Aristo Feed 3004 U6 Ready-to-Weld Package	0561000064
Origo MIG 4002c/Aristo Feed 3004 U6 Basic Package	0561000065	Origo MIG 4002c/Aristo Feed 3004 U8 <sub>2</sub> Plus Ready-to-Weld Package	0561000066
Origo MIG 4002c/Aristo Feed 3004 U8 <sub>2</sub> Plus Basic Package	0561000067		



# Origo® Mig 4002c/5002cw/6502c

**MULTI-PROCESS MACHINES**

## Origo Mig 5002cw - Ordering Information (not for sale in USA)

Origo MIG 5002cw CVCC, 230/460/575 V, 3 ph, 60 Hz Power Source	0349311820	Origo MIG 5002cw/Origo Feed 3004 MA23 Basic Package	0561000081
Origo MIG 5002cw/Origo Feed 3004 MA24 Basic Package	0561000083	Origo MIG 5002cw/Aristo Feed 3004 U6 Basic Package	0561000085
Origo MIG 5002cw/Aristo Feed 3004 U <sub>2</sub> Plus Basic Package	0561000087		

## Origo Mig 6502c - Ordering Information

USA			
Origo MIG 6502c CVCC, 230/460 V, 3 ph, 60 Hz Power Source*	0349312410	Origo MIG 6502cw CVCC, 230/460 V, 3 ph, 60 Hz Power Source	0349311400
Origo MIG 6502/Origo Feed 3004 MA23 Ready-to-Weld Package	0558101336	Origo MIG 6502c/Origo Feed 3004 MA23 Basic Package	0558101337
Origo MIG 6502c/Origo Feed 3004 MA24 Ready-to-Weld Package	0558101342	Origo MIG 6502c/Origo Feed 3004 MA24 Basic Package	0558101343
Origo MIG 6502c/Aristo Feed 3004 U6 Ready-to-Weld Package	0558101348	Origo MIG 6502c/Aristo Feed 3004 U6 Basic Package	0558101349
Origo MIG 6502c/Aristo Feed 3004 U <sub>2</sub> Plus Ready-to-Weld Package	0558101358	Origo MIG 6502c/Aristo Feed 3004 U <sub>2</sub> Plus Basic Package	0558101359
<i>*Includes 115 VAC, 10 A outlet.</i>			
Canada			
Origo MIG 6502c CVCC, 230/460/575 V, 3 ph, 60 Hz Power Source	0349312740	Origo MIG 6502/Origo Feed 3004 MA23 Ready-to-Weld Package	0561000090
Origo MIG 6502c/Origo Feed 3004 MA23 Basic Package	0561000091	Origo MIG 6502c/Origo Feed 3004 MA24 Ready-to-Weld Package	0561000092
Origo MIG 6502c/Origo Feed 3004 MA24 Basic Package	0561000093	Origo MIG 6502c/Aristo Feed 3004 U6 Ready-to-Weld Package	0561000094
Origo MIG 6502c/Aristo Feed 3004 U6 Basic Package	0561000095	Origo MIG 6502c/Aristo Feed 3004 U <sub>2</sub> Plus Ready-to-Weld Package	0561000096
Origo MIG 6502c/Aristo Feed 3004 U <sub>2</sub> Plus Basic Package	0561000097		

For more information on WeldCloud online weld management platform, see separate factsheet or contact ESAB representative.

All Origo MIG machines come with installed wheel kit and single cylinder tray.

RTW (Ready To Weld) packages include power source, wire feeder with .035-.045 in. (0.9-1.2 mm) V-groove feedrolls, 5.5 ft. (1.7 m) connection set, Spraymaster V350 15 ft. (4.5 m), and Victor ESS32-80CFH-580 Flow regulator.

Basic packages include power source, wire feeder with .035-.045 in. (0.9-1.2 mm) V Feedrolls, 15 ft. (4.5 m) Spray Master Torch V350, and Victor ESS32-80CFH-580 Flow regulator.

Use Basic packages to make extended reach packages.

## Options and Accessories - Origo Mig 4002c, 5002cw, 6502c

WeldCloud Mobile	0464550880
Two cylinder shelf	0349312790
Electrode holder assembly, 300 A, 15 ft. (4.5 m)	21226
Remote control MTA1 CAN	0459491880
Remove control AT1 CAN	0459491883

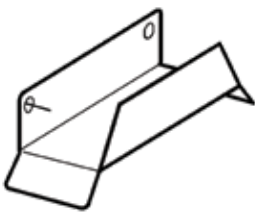
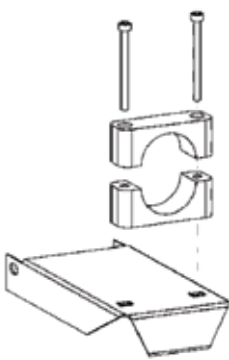
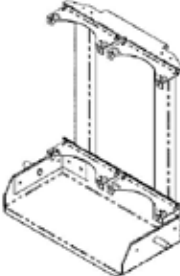
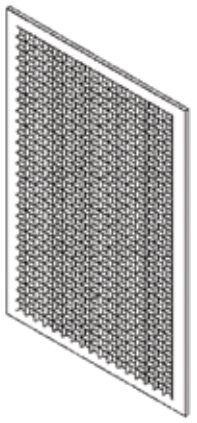
 <p><b>Cable Holder</b> Part Number: 0349303362 One per side.</p>	 <p><b>Power Source Strain Relief for Connection Cables</b> Part Number: 0349311700 Recommended when moving power supply frequently and use of long connection sets.</p>	 <p><b>Two Cylinder Shelf</b> Part Number: 0349312790</p>	 <p><b>Air Filter</b> Part Number: 0349302252</p>
--	---	---	--

## Aristo® Mig 4004i Pulse

Light weight, multi-process inverter power source

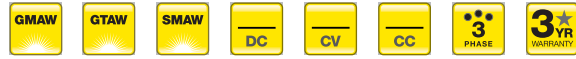

[esab.com/weldcloud](http://esab.com/weldcloud)



Aristo Mig 4004i Pulse shown with U8<sub>2</sub> Plus, cooler & Trolley 11

- 400A @ 60%, 300A @ 100% duty cycle for handling
- Aristo® Mig 4004i Pulse is designed for high quality, high productivity welding applications
- Features the latest inverter technology to efficiently weld mild steel, stainless steel and aluminum using solid or flux cored wire
- Offers a considerably improved power factor, better than 0.94 and an efficiency of 88% providing minimized energy consumption and significant reductions in your energy cost under similar welding conditions
- Pulse functionality reduces heat input and minimizes spatter
- Available with WeldCloud data management system
- ESAB LogicPump prevents overheating of the torch
- TrueArcVoltage™ system measures the correct arc voltage at the contact tip (together with ESAB torches)

MULTI-PROCESS MACHINES

### Specifications

Input Voltage	Current Range DC	Rated kVA	Fuse Slow	Efficiency @ Max Current	Power Factor @ Max Current
380 – 460 V, 3 ph, 50/60 Hz	MIG (GMAW/FCAW) 16 – 400 A Stick (SMAW) 16 – 400 A TIG (GTAW) 4 – 400 A	25.2 kVA	20 A	88%	94%
Welding Output	Open Circuit Voltage	Operating Temperature		Energy Saving Mode	
400 A/34 V @ 60% Duty Cycle 300 A/29 V @ 100% Duty Cycle	55 V or < 35 V VRD	14 to 104 °F (-10 to 40 °C)		40 W	
Protection Class	Dimensions L x W x H	Weight			
IP23S	24 x 10 x 17.5 in. (610 x 250 x 445 mm)	98 lbs. (44.5 kg)		128 lbs. (58 kg) with COOL 1 water cooler	

### Ordering Information (not for sale in Canada)

Aristo Mig 4004i Pulse, 460V	0465152882	Aristo Mig 4004i Pulse/3004 U6 Ready-To-Weld	0558102268
Aristo Mig 4004i Pulse/3004 U8 <sub>2</sub> Plus Ready-To-Weld	0558102269	Aristo Mig 4004i Pulse/3004 U6 Basic	0558102226
Aristo Mig 4004i Pulse/3004w U6 Basic	0558102227	Aristo Mig 4004i Pulse/3004 U8 <sub>2</sub> Plus Basic	0558102228
Aristo Mig 4004i Pulse/3004w U8 <sub>2</sub> Plus Basic	0558102229	Aristo Mig 4004i Pulse U6 for PPG 26 KD Push-Pull Gun	0558102264
Aristo Mig 4004i Pulse U8 <sub>2</sub> Plus for PPG 26 KD Push-Pull Gun	0558102265	Aristo Mig 4004i Pulse, with WeldCloud Top Box*	0445301881

\*For more information on WeldCloud online weld management platform, see WeldCloud fact sheet or visit [esab.com](http://esab.com).

# Aristo® Mig 5000i/U5000i

Advanced synergic multi-process welder

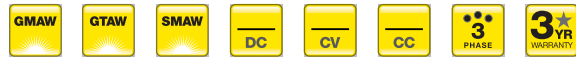

[esab.com/weldcloud](http://esab.com/weldcloud)



- The multi-process Aristo® Mig 5000i power source provides substantially improved arc welding performance and higher productivity for robotic and semi-automatic applications
- Designed to integrate with ESAB's industry-leading WeldCloud™ online data management platform via Wi-Fi, mobile cellular or hard-wired Ethernet communication
- Proven, robust, heavy-duty industrial system that holds up in the most demanding welding environments
- Modular design allows connection of U6 or U8<sub>2</sub> Plus via mount to feeder or to power source – great for when feeder is boom mounted and hard to reach for normal operation
- U5000i model available for adding process capabilities such as DC TIG and DC Pulse TIG with ESAB TXH torches
- TrueArcVoltage™ system measures the correct arc voltage at the contact tip (together with ESAB torches)
- Contact ESAB for Robotic Welding Automation to see how the Aristo Mig 5000i model and U8<sub>2</sub> Plus Pendant can be integrated for robotic welding systems

MULTI-PROCESS MACHINES

## Specifications

Input Voltage	Current Range DC		Rated kVA	Fuse Size	Efficiency @ Max Current	Power Factor @ Max Current
3 x 460 V, 3 ph, 50/60 Hz 3 x 208/230/400/460/575 V, 3 ph, 50/60 Hz	MIG (GMAW/FCAW) Stick (SMAW) TIG (GTAW)	16 – 500 A, 8 – 60 V 16 – 500 A 4 – 500 A	25.2 kVA	32 A	87%	91%
Welding Output	Control Voltage	Open Circuit Voltage		Operating Temperature	Energy Saving Mode	
500 A/40V at 100 % Duty Cycle 400 A/36 V at 60% Duty Cycle	42 V	MIG (GMAW) Stick (SMAW)	72 – 88 V (59 V VRD) 68 – 80 V (< 35 V VRD)	14 to 104 °F (-10 to 40 °C)	50 W	
Mains Cable	Protection Class	Dimensions L x W x H		Weight		
4x8 AWG (4x6 mm <sup>2</sup> )	IP23	24 x 10 x 17.5 in. (610 x 250 x 445 mm) 24.6 x 15.5 x 30.6 in. (625 x 394 x 776 mm) w/cooling unit 24.4 x 15.3 x 10.5 in. (621 x 389 x 266 mm) multi-voltage unit		159 lbs. (72 kg) 203 lbs. (92.1 kg) w/cooling unit 165.4 lbs. (75 kg) multi-voltage unit		

## Ordering Information

Aristo Mig 5000iDC CVCC 460V	0459230884	Aristo Mig 5000i DC CVCC 460V with WeldCloud	0445400884
Aristo Mig U5000i DC CVCC 460V	0459230885	Aristo Mig U5000i DC CVCC 460V with WeldCloud	0445400885
Aristo Mig U5000iw DC CVCC 460V	0459230886	Aristo Mig U5000iw DC 460V with WeldCloud	0445400886
Aristo Mig 5000i DC, 208-575V, 3 ph, 60Hz (Canada)	0459230880MV	Aristo Mig U5000iw DC, 208-575V, 3ph, 60Hz (Canada)	0459230881MV
Aristo Mig 5000i / 4004HD U6 RTW Stationary	0558102467	Aristo Mig 5000i / 4004HD U8 <sub>2</sub> Plus RTW Stationary	0558102468
Aristo Mig 5000i / 4004HD U6 RTW MIG Racer	0558102469	Aristo Mig 5000i / 4004HD U8 <sub>2</sub> Plus RTW MIG Racer	0558102470
Aristo Mig 5000i / 3004 U6 RTW Stationary	0558102266	Aristo Mig 5000i / 3004 U8 <sub>2</sub> Plus RTW Stationary	0558102267
Aristo Mig U5000i / 3004 U6 RTW Stationary	0558101378	Aristo Mig U5000i / 3004 U8 <sub>2</sub> Plus RTW Stationary	0558101379

For more information on WeldCloud online weld management platform, see WeldCloud fact sheet or visit [esab.com](http://esab.com).

Power source includes: 16.4 ft. (5 m) mains cable. U5000iw include built-in-water cooler.

RTW (Ready To Weld) Stationary Packages: power source, wire feeder, .035/.045 in. (0.9/1.2 mm) V groove feedrolls, V450 15ft. (4.5 m) MIGgun, 5.5 ft. (1.7 m) connection set (gas hose, control cable, welding current cable), 15 ft. (4.5 m) work cable and clamp, regulator/flowmeter.

RTW MIGRacer Packages include: the above plus HD 2-Cylinder Cart.

## Aristo® Mig 4004i Pulse & 5000i/U5000i Accessories

Options & Accessories	
Aristo Feed 3004, U6 Encl. 10 pole, air-cooled	0460526486
Aristo Feed 3004w, U6 Encl. 10 pole, water-cooled	0460526896
Aristo Feed 3004, U8 <sub>2</sub> Plus Encl. 10 pole, air-cooled	0460526481
Aristo Feed 3004w, U8 <sub>2</sub> Plus Encl. 10 pole, water-cooled	0460526891
Aristo YardFeed 200w, U6 Encl. 10 pole, water-cooled	0459906896
Aristo U8 <sub>2</sub> Plus	0460820881
Aristo U8 <sub>2</sub> Plus control cable extension, 24.6 ft. (7.5 m)	0460877891
Strain relief for welding gun	0457341881
Lifting eye	0458706880
Quick connector for Marathon Pac	899F50
Inlet guide for Marathon Pac (use with 899F50)	0558002354
Remote control MTA1 CAN	0459491880
Remote interconnection cable, 16.4 ft. (5 m)	0459960880
Remote adapter kit for Miggytrac/Railtrac	0459681880
Push-pull gun connection kit, basic	0459020883
Push-pull gun connection kit, remote WFS	0459681881
COOL 1 water cooler	0462300880
COOL 1 flow guard	0456855881
Adapter for 11 lbs. (5 kg) spool	0455410001
Spool cover, steel	0459431880
Adapter for spool diameter 17 in. (440 mm)	0459233880
Wheel kit for wire feeder	0458707880
Trolley 4-wheel - standard	0462151880
Trolley 4-wheel - standard, bracket (without COOL 1)	0463125880
Trolley 2-wheel	0460564880
Trolley 4-wheel - for MiniBoom	0460565880
Bracket kit to assemble power source to 2/4-wheel trolley	0461310880
Trolley 4-wheel stabilizer kit for counterbalance device	0460946880
MiniBoom counterbalance device	0458705880
Multi Voltage unit, Wide body (208-575V, 3-ph transformer)	0459145880
Heavy-Duty Dual Cylinder Cart (cannot be used with U5000iw + multi-voltage unit)	0558102236
Guide pin (if no trolley) (3004 feeders only)	0458731880
Remote control MTA1 CAN	0459491880
Remote control AT1 CAN	0459491883
Remote control AT1 CourseFine CAN	0459491884
Work Cable GC-500 15 ft. (4.5 m) 4/0	0558102318
Foot pedal T1 Foot CAN, incl. 16.4 ft. (5 m) cable with 10 pole plug, for connection to the feeder with U6 panel	0460315881
Foot pedal T1 Foot CAN, incl. 16.4 ft. (5 m) cable with 12 pole plug, for connection to the feeder for U8 <sub>2</sub> Plus	0460315880
Trolley 2 for counter balance device and/or 2 gas bottles	0458603880
Quick connector kit for current, water and shielding gas supply for 2x Aristo Feed	0459546880
MMC kit for MMC panel mounted in the power source	0459579880
Water Flow guard complete	0456855880

MULTI-PROCESS MACHINES

# Aristo® Mig 4004i Pulse & 5000i/U5000i Accessories

Aristo Mig 4004i Pulse Accessories				
 <p><b>COOL 1 Water Cooler</b> Part Number: 0462300880</p>	 <p><b>Trolley 11 4-wheel standard</b> Part Number: 0462151880</p>	 <p><b>Trolley 9 4-wheel</b> Part Number: 0460565880, For use with MiniBoom.</p>	MULTI-PROCESS MACHINES	
 <p><b>Trolley 9 Adapter Kit</b> Part Number: 0461310880, For use with MiniBoom.</p>	 <p><b>Stabilizer Kit for Counter Balance Device</b> Part Number: 0460946880, For use with Trolley 9.</p>	 <p><b>COOL 1 Flow Guard</b> Part Number: 0456855881</p>		
 <p><b>Bracket for Trolley 11</b> Part Number: 0463125880, Not for use with WeldCloud.</p>	 <p><b>Trolley 4-wheel</b> Part Number: 0445499880, For use with WeldCloud.</p>	 <p><b>Trolley 4-wheel</b> Part Number: 0460565880, For use with WeldCloud COOL 1.</p>		
Aristo Mig 5000i/U5000i Accessories				
 <p><b>Multi Voltage Unit, Wide Body</b> Part Number: 0459145880</p>	 <p><b>MMC kit for MMC panel mounted in power source</b> Part Number: 0459579880</p>	 <p><b>Guide Pin (if no Trolley used) For use with Feed 3004 only</b> Part Number: 0458731880</p> <p><b>Insulating Bushing (b), included in guide Pin</b> Part Number: 0278300401</p>		 <p><b>Cable Holder Kit</b> Part Number: 0349302303</p>
 <p><b>Trolley 2</b> Part Number: 0458603880 For MiniBoom and/or 2 gas bottles.</p>	 <p><b>Trolley 2</b> Part Number: 0458603880 For MiniBoom and/or 2 gas bottles.</p>	 <p><b>Aristo W82</b> Contact ESAB for more information for information on Robotic welding WeldCloud.</p>		 <p><b>Trolley 2</b> Part Number: 0458603880 For MiniBoom and/or 2 gas bottles.</p>

## MobileFeed 201AVS & 301AVS

Versatile voltage-sensing wire feeders for use with any CV or CC welding power supply



- Portable, durable wire feeder, available with Tweco connect, built for the toughest welding conditions, with rugged case to stand up to demanding work environments and optimal protection for internal components
- Quick-change, four-roll drive reduces downtime and provides consistent feeding results; rolls are easily changed from one wire size to another without the need for tools
- Digital meters for both Voltage and WFS ensure more arc time, are labor-saving and beneficial for critical welds using specific welding procedures
- Rugged case withstands the harshest environments, keeping downtime for repairs to a minimum
- Robustly designed rubber-mounted internals prevents damage caused by drops and impacts.
- Remote control option, available when used with the Warrior™ power supply, allows voltage to be adjusted away from the power supply, reducing setup time and enabling long welds in difficult-to-reach areas

### Specifications

Welding Output	Wire Feed Speed	Wire Diameter	Max Spool Diameter	Dimensions L x W x H	Weight
450A @ 60% duty cycle 400A @ 100% duty cycle	50 – 750 ipm (1.3 – 19.0 m/min)	.045 – 1/16 in. (1.2 – 1.6 mm) Knurled drive rolls as delivered  Range 201AVS: .023 – 1/16 in. (0.6 – 1.6 mm) Range 301AVS: .023 – 5/64 in. (0.6 – 2.0 mm)	201AVS: 8 in. (200 mm) 301AVS: 12 in. (304.8 mm)	201AVS: 18.5 x 14.5 x 7.375 in. (470 x 369 x 187 mm)  301AVS: 21 x 17 x 8 in. (534 x 435 x 207 mm)	201AVS: 28 lbs. (13 kg) without spool  301AVS: 35 lbs. (15.9 kg) without spool

### Ordering Information

MobileFeed 201AVS w/Meters-Rem V TWECO	0558101911
MobileFeed 201AVS w/o Meters TWECO	0558102194
MobileFeed 301AVS w/Meters-Rem V TWECO	0558101919
MobileFeed 301AVS w/o Meters TWECO	0558102195

## Warrior™ Feed 304

Simple functionality, multi-process wire feeder



- Economical wire feeder with the same benefits as Warrior 400i MV and 500i power supplies; simple functionality, rugged durability, and outstanding performance
- Sturdy design with galvanized metal casing for use in tough environments
- Electronically controlled feeding gives accurate and stable arc
- The 4-roll feeder mechanism with grooves in both feed roll and pressure roll gives stable feeding and low wear on the wire, all to avoid operational disturbance
- New drive motor offers more torque for improved arc starts, more consistent speed and less noise
- Easy-to-use controls (remote voltage, gas purge, inch wire, WFS) trigger lock, and slow run-in make configuration easy
- Short Circuit Termination (SCT) technology sharpens the wire at the end of each weld to promote better arc starts

### Specifications

Input Voltage	Operating Temperature	Wire Feed Speed	Max Spool Diameter	Wire Diameter	
42 VAC, 1 ph, 50/60 Hz	14 – 104°F (-10 – 40°C)	32 – 1000 ipm (0.8 – 25.4 m/min)	12 in. or 17 in. (305 mm or 432 mm)	Mild Steel	.023 – 1/16 in. (0.6 – 1.6 mm)
<b>Protection Class</b>	<b>Dimensions L x W x H</b>	<b>Weight</b>		Flux Cored	.023 – 1/16 in. (0.6 – 1.6 mm)
IP23	10.0 x 18.1 x 29.7 in. (255 x 460 x 755 mm)	48 lbs. (21.5 kg)		Stainless Steel	.040 – 1/16 in. (1.0 – 1.6 mm)
				Aluminum	.035 – 1/16 in. (0.9 – 1.6 mm)

### Ordering Information

Warrior Feed 304 Air-Cooled	0465250880
Warrior Feed 304w Water-Cooled	0465250881
Warrior Feed 304, ST-16/21 Compatible	0588002048

## Warrior™ Feed 404HD

Heavy-duty industrial wire feeder



- Heavy-duty wire feeder engineered for use with the Warrior 500i and Warrior 400i MV CC/CV systems
- Quick-change, heavy-duty drive roll design reduces downtime and provides consistent wire feeding performance for .030 to 3/32 in. (0.8 to 2.5 mm) wire in high-volume and heavy fabrication applications
- Increased productivity through a heavy-duty drive system that delivers high starting torque, rapid response, and reliable feedability in the most demanding applications
- Sun-friendly preset voltage, preset WFS and amperage digital meter displays
- Lower cost of drive roll replacement by 50% as compared to 4-roll driven system
- Upper idler drive system greatly reduces wire distortion and wear in MIG gun parts

### Specifications

Input Voltage	Welding Output	Wire Feed Speed	Operating Temperature	Wire Diameter	
42 VAC, 1 ph, 50/60 Hz	550 A @ 60% Duty Cycle 450 A @ 100% Duty Cycle	60 – 750 ipm (1.5 – 19 m/min)	32 – 104°F (0 – 40°C)	Mild Steel	.035 – 1/16 in. (0.9 – 1.6 mm)
<b>Protection Class</b>	<b>Dimensions L x W x H</b>	<b>Weight</b>		Flux Cored	.035 – 1/8 in. (0.9 – 3.2 mm)
IP23S	10.0 x 18.1 x 29.7 in. (255 x 460 x 755 mm)	48 lbs. (21.5 kg)		Aluminum	.045 – 3/32 in. (1.2 – 2.4 mm)

### Ordering Information

WarriorFeed 404HD (Tweco)	0558102235	Tweco #5 Adapter Kit for Large Wire	W4017601
---------------------------	------------	-------------------------------------	----------

## Warrior™ Feed Dual 304

Dual wire feeder solution



- Warrior™ Feed Dual 304 is compatible with Warrior 500i CC/CV and Warrior 400i MV CC/CV welding systems
- The dual wire feeder functionality provides flexibility in environments requiring dual applications with the use of a single power source
- Delivered with Euro or Tweco-style MIG gun connections
- Increased productivity through elimination of wire spool change out in demanding applications
- Activation of left or right drive selectable with torch trigger
- Sun-friendly, pre-settable voltage, pre-settable WFS and amperage digital meter displays
- Upper idler drive system greatly reduces operating cost by reducing wire scrubbing and wear in MIG gun parts, cutting feedroll costs by up to 50%
- Full functionality with trigger lock, slow-run-in, SCT/burn-back, inch and gas purge

### Specifications

Input Voltage	Wire Feed Speed	Max Spool Diameter	Operating Temperature	Wire Diameter	
42 VAC, 1 ph, 50/60 Hz	75 – 950 ipm (2.0 – 24 m/min)	17.7 in. (450 mm)	32 – 104°F (0 – 40°C)	Mild Steel	.023 – 1/16 in. (0.6 – 1.6 mm)
<b>Dimensions L x W x H</b>			<b>Weight</b>		
24 x 16 x 14 in. (610 x 410 x 360 mm)			53 lbs. (24 kg)		
				Flux Cored	.035 – 5/64 in. (0.9 – 2.0 mm)
				Aluminum	.023 – 1/16 in. (0.6 – 1.6 mm)

### Ordering Information

Warrior Feed Dual 304 (Tweco Connection)	0558101947
Warrior Feed Dual 304 (Euro Connection)	0558101946

WIRE FEEDERS

## Warrior™ YardFeed 200

Highly portable wire feeder



- Pre-settable wire feed speed and small footprint to conveniently fit through manholes and portals with the flexibility to weld in hard-to-reach areas
- Sturdy design features a high-strength steel casing and steel frame to protect controls and connectors
- Easy handling in cramped spaces
- 4-wheel feeder mechanism with encoder feedback for superior wire feeding
- Sun friendly digital V/A and wire feed speed displays
- Variant with water connectors for water-cooled torches available

### Specifications

Input Voltage	Welding Output	Wire Feed Speed	Operating Temperature	Wire Diameter	
42 VAC, 1 ph, 50/60 Hz	365 A @ 60% Duty Cycle	75 – 985 ipm (1.9 – 25 m/min)	14 – 104°F (-10 – 40°C)	Mild Steel	.023 – .045 in. (0.6 – 1.2 mm)
<b>Protection Class</b>			<b>Dimensions L x W x H</b>		
IP23S			23.4 x 8.5 x 12.8 in. (595 x 215 x 325 mm)		
			<b>Weight</b>		
			48 lbs. (21.5 kg)		
				Stainless Steel	.023 – .045 in. (0.6 – 1.2 mm)
				Flux Cored	.030 – 1/16 in. (0.8 – 1.6 mm)
				Aluminum	.040 – .045 in. (1.0 – 1.2 mm)

### Ordering Information

Warrior YardFeed 200, air-cooled	0459906900
Warrior YardFeed 200, water-cooled	0459906901



## Ultrafeed 404HD

Heavy-duty 4-roll wire feeder



- Use with Warrior™ 300i power supply
- Advanced adjustable features for optimum welding performance; preflow, run in, ramp time, postflow, burnback, crater control, spot and stitch
- Heavy-duty 4-roll drive system for superior wire feeding
- Digital meters for voltage, amperage, wire feed speed; preview and hold capability
- Trigger and spot control: 4T (latch) eliminates operator fatigue, spot welding capability
- Weld schedules allow operator to store two optimized welding parameters then digitally recall them with perfect repeatability
- Inch and purge buttons for advancing wire or purging shielding gas
- Circuit breaker protection - no fuses required
- Indicator lights to identify power and faults; plus control settings over amps and wire feed speed for ipm or mpm

Specifications					
Input Voltage	Welding Output	Wire Feed Speed	Max Spool Diameter	Wire Diameter	
42/115 VAC, 1 ph, 50/60 Hz	550 A @ 60% Duty Cycle 450 A @ 100% Duty Cycle	50 - 660 ipm (1.35 - 16.75 m/min)	8 in. and 12 in. (200 mm and 300 mm)	Mild Steel	.035 - 1/16 in. (0.9 - 1.6 mm)
<b>Dimensions L x W x H</b>		<b>Weight</b>		Flux Cored	.030 - 1/8 in. (0.8 - 3.2 mm)
10.0 x 18.1 x 29.7 in. (255 x 460 x 755 mm)		48 lbs. (21.5 kg)		Stainless Steel	.035 - 1/16 in. (0.9 - 1.6 mm)
				Aluminum	.035 - 3/32 in. (1.0 - 2.4 mm)
Ordering Information (not for sale in Canada)					
Ultrafeed 404HD			W3400003		

WIRE FEEDERS

## Origo® Feed 3004 MA23/MA24

Advanced Multi-Process Functionality



Origo Feed 3004 MA23



Origo Feed 3004 MA24

- The MA23 is a sturdy, easy-to-use wire feeder with the features you need for reliable GMAW (MIG) and SMAW (Stick) applications with memory
- The MA24 has all the features of the MA23 plus creep start, crater filling, QSet™ and synergic lines for short-arc and spray-arc
- Sturdy design with galvanized metal casing for use in tough environments
- Electronically controlled feeding gives accurate and stable arc
- The 4-roll feeder mechanism with grooves in both feed roll and pressure roll gives stable feeding and low wear on the wire, all to avoid operational disturbance
- The feeders are available with 1.2 in. (30 mm) diameter rollers for wires .023-1/16 in. (0.6-1.6 mm) Steel, Stainless Steel, and .040 -1/16 in. (1.0-1.6 mm) Aluminum
- Short Circuit Termination (SCT) technology sharpens the wire at the end of each weld to promote better arc starts

Specifications				
Input Voltage	Wire Feed Speed	Max Spool Diameter	Wire Diameter	
42 VAC, 1ph, 50/60 Hz	32-1000 ipm (0.8-25.0 m/min)	12 in. (300 mm) 17 in. (440 mm)	Mild Steel	.023 - 1/16 in. (0.6 - 1.6 mm)
<b>Dimensions L x W x H</b>		<b>Weight</b>		Flux Cored
27.1 x 10.8 x 16.1 in. (690 x 275 x 420 mm)		33 lbs. (15 kg)		Stainless Steel
				Aluminum
				.035 - 1/16 in. (0.9 - 1.6 mm)
Ordering Information				
Origo Feed 3004 MA23 Air-Cooled	0460526487	Origo Feed 3004 MA24 Air-Cooled	0460526489	
Origo Feed 3004 MA23 Water-Cooled	0460526897	Origo Feed 3004 MA24 Water-Cooled	0460526899	

## Aristo® Feed 3004

Advanced synergic multi-process wire feeders



- Multiple panel options with U6, U8<sub>2</sub> Plus and MA25 for specialized steel and aluminum applications
- The 4-roll feeder mechanism with grooves in both feed roll and pressure roll gives stable feeding and low wear on the wire, all to avoid operational disturbance
- Available with either 1.2 in. (30 mm) diameter rollers for wires .023 - 1/16 in. (0.6 - 1.6 mm) steel, stainless and .040 - 1/16 in. (1.0 - 1.6 mm) aluminum
- New drive motor offers more torque for improved arc starts, more consistent speed and less noise
- Short Circuit Termination (SCT) technology sharpens the wire at the end of each weld to promote better arc starts
- Can be equipped with a counter balance arm, lifting eye or a wheel kit for increased mobility

### Specifications

Input Voltage	Wire Feed Speed	Max Spool Diameter	Wire Diameter	
42 VAC, 50/60 Hz	32 – 1000 ipm (0.8 – 25.0 m/min)	12 in. (300 mm)	Mild Steel	.023 – 1/16 in. (0.6 – 1.6 mm)
<b>Dimensions L x W x H</b>		<b>Weight</b>	Flux Cored	.035 – 1/16 in. (0.9 – 1.6 mm)
27.1 x 10.8 x 16.1 in. (690 x 275 x 420 mm)		33 lbs. (15 kg)	Stainless Steel	.023 – 1/16 in. (0.6 – 1.6 mm)
			Aluminum	.035 – 1/16 in. (0.9 – 1.6 mm)

### Ordering Information

Aristo Feed 3004 (MA25 Steel)	0460526682	Aristo Feed 3004 (MA25 Aluminum)	0460526680	Aristo Feed 3004 for U8 <sub>2</sub> Plus, Air-Cooled	0460526481
Aristo Feed 3004, U6, Air-Cooled	0460526486	Aristo Feed 3004w (MA25 Steel)	0460526683	Aristo Feed 3004w (MA25 Aluminum)	0460526681
Aristo Feed 3004 for U8 <sub>2</sub> Plus, Water-Cooled	0460526891	Aristo Feed 3004, U6, Water-Cooled	0460526896	Aristo U8 <sub>2</sub> Plus Pendant Complete	0460820881

## Aristo® Feed 4004HD

Advanced heavy-duty industrial wire feeder



- This advanced heavy-duty wire feeder is compatible with Aristo 5000i and Aristo 4004i Pulse welding systems
- Multiple panel options are available with U6 and U8<sub>2</sub> Plus, choose your level of control
- Upper idler drive system greatly reduces wire distortion and wear in MIG gun parts cutting feedroll cost by 50% offering a huge cost benefit
- Increased productivity through a heavy-duty drive system that delivers reliable feedability in the most demanding applications
- Pre-programmed synergic lines, memory for parameter sets, QSet™ and the ability to create synergic lines with the U6 & U8<sub>2</sub> Plus (requires ESAT software)
- Crater filling, adjustable burnback time and post gas, creep start, gas pre-flow and hot start

### Specifications

Input Voltage	Wire Feed Speed	Max Spool Diameter	Wire Diameter	
42 VAC, 1 ph, 50/60 Hz	50 – 800 ipm (1.3 – 18.0 m/min)	18 in. (440 mm)	Mild Steel	.030 – 1/16 in. (0.8 – 1.6 mm)
<b>Dimensions L x W x H</b>		<b>Weight</b>	Flux Cored	.035 – 1/8 in. (0.9 – 3.2 mm)
29.7 x 18.1 x 10 in. (755 x 460 x 255 mm)		51 lbs. (23 kg)	Stainless Steel	.030 – 1/16 in. (0.8 – 1.6 mm)
			Aluminum	.035 – 1/16 in. (0.9 – 1.6 mm)

### Ordering Information (not for sale in Canada)

Aristo Feed 4004HD, U6 Encl. 10 Pole	0558102234	Aristo Feed 3004 with U8 <sub>2</sub> Plus Complete	0558102480
--------------------------------------	------------	---	------------

# Wire Feeder Control Panels

MMC Panel Function	MA23	MA24	MA25	U6	U8 <sub>2</sub> Plus
					
SMAW/GMAW	■	■	■	■	■
GMAW-PULSE (synergic)			■	■	■
CAG (GOUGING)				■	■
GTAW				■	■
GTAW-PULSE (U5000i only)				■	■
Unit of Measurement (Imperial/Metric)	■	■	■	■	■
Trigger Latch	■	■	■	■	■
Memory Presets	3	3	3	10	255
Gas Purge/Wire Inch	■	■	■	■	■
Arc Force adjustment				■	■
Hot Start adjustemnt				■	■
Gas preflow/post flow					
Creep Start	■	■	■	■	■
Crater Filling		■	■	■	■
Burnback adjustment	■	■	■	■	■
Adjustable Inductance	■	■	■	■	■
Hidden functions menu1)	■	■	■		
Weld Schedule trigger toggle	■	■	■	■	■
External remote control	■	■	■	■	■
Synergic Control/programs		35	55/292	60	230
Qset		■	■	■	■
SuperPulse					■
Trigger Control Hot start					■
Time control Hot Start				■	■
Setiings Limit Editor					■
Code Lock (password access)					■
User Accounts					■
Create Customized Synergic lines					■
Production Data					■
Weld Data recording					up to 100
Language Options				■	■
VRD	■	■	■	■	■
WeldCloud compatible				■	■

WIRE FEEDERS

## Aristo® U8<sub>2</sub> Plus Controller

Developed for durability and usability



- ESAB introduced the second generation of Aristo U8<sub>2</sub> digital controllers offering improved welding capacity and operator convenience
- The new U8<sub>2</sub> Plus has been developed as an addition to our Origo® and Aristo® power sources and wire feeder devices as users demanded more functionality and functions
- Designed for advanced manual and mechanized MIG/MAG welding, Pulsed MIG/MAG, TIG, Pulse TIG, STICK welding, as well as carbon arc gouging
- User-friendly design and interface
- Complex controllers are often impossible to understand without an in-depth knowledge of the product - not so with the U8<sub>2</sub> Plus
- The few controls that it has to guide the welder intuitively are ergonomically very easy to use even when wearing protective gloves
- The large, bright display is clear and easy to read, with full text in English and 16 other languages
- It does not have a multitude of tiny knobs or buttons, nor does it use incomprehensible abbreviations

**QSet™** is the best single parameter automatic arc system on the market for the perfect short arc. The advantages are enormous! You set up the machine with the appropriate gas/wire combination, press the torch switch and start welding within seconds.

The machine determines the optimum parameters and makes any changes as required in a fraction of a second. The wire stick out which is normally a constant length in MIG/MAG welding, can be varied with QSet™.

Whether you are close to the work piece with the torch or so far away that the gas protection almost ceases, the welding arc remains unchanged - always perfect. Unbeatable in deep seams, if you have to weld around corners or are welding upwards coming out of the downhand position.

Utilized with CO<sub>2</sub> gas you can weld with QSet with extremely low levels of spatter and can drastically reduce the gas costs, compared with mixed gas, without any loss of quality.

QSet is ideal for welding in restricted positions, root welding, GMA brazing and for reproducible results in the series production of parts. QSet is also available in many other ESAB controller / machine combinations.

### Synergic Lines

In the Aristo U8<sub>2</sub> Plus you have more than 230 synergic lines available to you for your welding applications. From construction steel to Super Duplex, from aluminium to Ni basic alloys or for applications of hard metal. You can create customized synergic lines yourself for any desired material and any combination of protective gas and save them as new synergic lines. You can transfer data via the USB connection, to another Aristo U8<sub>2</sub> or to your computer for data backup or exchange by e-mail.

### SAT – Swift Arc Transfer™ (Robotic Welding Only)

Swift Arc Transfer (SAT) is a high productivity GMAW process using AristoRod™ non-copper coated wires with Advanced Surface Characteristics at travel speeds well beyond the limits of normal spray arc welding.

The advantage AristoRod non-copper-coated wire over copper-coated wires is that it does not contaminate the feed system with copper particles. Synergic lines are available for three AristoRod wire sizes and various shielding gases.

SAT produces flat welds with good penetration and without undercut. An additional advantage is the low heat input, resulting in less deformation. SAT is developed for robotic, automated and mechanized welding, and suited for fillet and overlap welds in thin to thick plate, in downhand positions.

SAT uses ESAB inverter power sources together with the Robofeed 3004 wire feeder for wire feed speeds up to 1200 ipm (30 m/min) in conjunction with U8<sub>2</sub> Plus control unit. ESAB provides a complete package of equipment, consumables, and synergic lines as well as the expertise to successfully implement the SAT process.

### Quality Control

For storage of the measured values you are offered two options in the form of the setting limits and measuring limits. The setting limits prevent the operator from inputting excessively high values for the welding process. The measuring limits ensure that the power source does not exceed the input values. Up to 16 User Accounts on three levels with various access rights and blocking codes can be used to prevent unauthorized persons from making changes.

### Production Statistics

The total arc time, total quantity of material and the number of welding processes can be logged per production statistics item. In addition, the arc time and amount of material for the last welding process are recorded, the total weld metal deposited can be recorded – and collected by WeldCloud™.

# Aristo® SuperPulse™

Innovative process for heat input control

An additional feature of the Aristo U8<sub>2</sub> Plus control is Aristo SuperPulse - a further development of the Pulse/Pulse concept, giving full control over the heat input and thereby expanding the scope of application of the GMAW process resulting in better gap bridging, reduction in distortion, and better balance of the weld penetration and its profile.

SuperPulse combines the relevant advantages of the various types of arc. For example, the quality of the pulsed arc with the productivity of the spray arc. Or pulse arc with short arc, to introduce the least amount of heat into the thinnest sheets of metal. Or the combination of two pulsed arcs with different frequencies, for example, for the MIG welding of aluminium with a TIG look. It also allows the working range of larger wires to be expanded increasing productivity.

Pulse/Pulse	Pulse/Short Arc	Spray/Pulse
<ul style="list-style-type: none"> <li>■ All position weldability</li> <li>■ Thicknesses from 0.1 to 0.5 in. (3 to 12 mm)</li> <li>■ Exceptional results on aluminum and stainless steel</li> <li>■ Aesthetically pleasing welds with uniform bead</li> </ul>	<ul style="list-style-type: none"> <li>■ Excellent performance on thin stainless and aluminum 0.4 to 0.2 in. (1 to 5 mm)</li> <li>■ Higher travel speeds compared to TIG</li> </ul>	<ul style="list-style-type: none"> <li>■ Better overall results on thicker weldments [0.2 in. (6 mm) and over]</li> <li>■ Better control of fusion and penetration</li> <li>■ Ability to weld thick aluminum vertical up with no weaving</li> </ul>

WIRE FEEDERS

## Aristo SuperPulse Benefits:

- Easier positional welding
- Uniform penetration
- Less sensitive for root gap variations and unequal heat transfer
- GTAW weld appearance with the GMAW process
- Suitable for automated welding, e.g./with ESAB Railtrac and Miggytrac automated welding tractors
- Extends the working range for larger wire sizes
- With its precisely adjustable heat input and depth of penetration, Aristo SuperPulse can solve difficult welding tasks and increase productivity



## Wire Feeder Connection Cable Sets











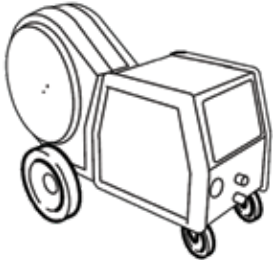

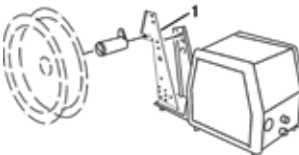
Warrior 400i/500i Connection Cable Sets for Warrior Feed Wire Feeders	
Air-Cooled	Water-Cooled
0459836880 – 6 ft (2 m)	0459836890 – 6 ft (2 m)
0459836881 – 16 ft (5 m)	0459836891 – 16 ft (5 m)*
0459836882 – 33 ft (10 m)	0459836892 – 33 ft (10 m)*
0459836883 – 50 ft (15 m)	0459836893 – 50 ft (15 m)*
0459836884 – 82 ft (25 m)*	0459836894 – 82 ft (25 m)*
0459836885 – 115 ft (35 m)*	0459836895 – 115 ft (35 m)*

Origo Mig 4002c/5002cw/6502c Connection Cable Sets for Origo Feed Wire Feeders	
Air-Cooled - US Only	Water-Cooled
0349312450 – 6 ft (2 m)	0459528990 – 6 ft (2 m)
0349312451 – 16 ft (5 m)	0459528991 – 16 ft (5 m)
0349312452 – 33 ft (10 m)	0459528992 – 33 ft (10 m)
0349312453 – 50 ft (15 m)	0459528993 – 50 ft (15 m)*
0349312454 – 82 ft (25 m)*	0459528994 – 82 ft (25 m)*
0349312455 – 115 ft (35 m)*	

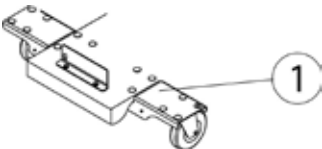
Aristo Mig 4004i/5000i/U5000i Connection Cable Sets for Aristo Feed Wire Feeders	
Air-Cooled - 4004i	Water-Cooled - 4004i
0349312450 – 6 ft (2 m)	0459528790 – 6 ft (2 m)
0349312451 – 16 ft (5 m)	0459528791 – 16 ft (5 m)
0349312452 – 33 ft (10 m)	0459528792 – 33 ft (10 m)
0349312453 – 50 ft (15 m)	0459528793 – 50 ft (15 m)
0349312454 – 82 ft (25 m)*	0459528794 – 82 ft (25 m)*
0349312455 – 115 ft (35 m)*	0459528795 – 115 ft (35 m)*
Air-Cooled - 5000i/U5000i	Water-Cooled - 5000i/U5000i
0459528901 – 6 ft (2 m)	0459528970 – 6 ft (2 m)
0459528961 – 16 ft (5 m)	0459528971 – 16 ft (5 m)
0459528962 – 33 ft (10 m)	0459528972 – 33 ft (10 m)
	0459528973 – 50 ft (15 m)

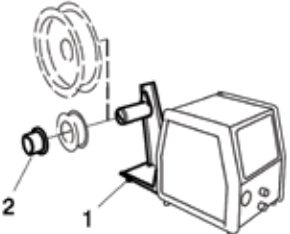
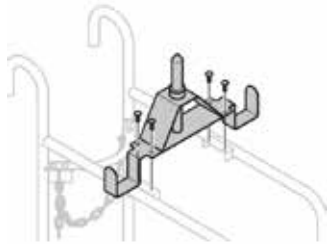
\* Special order lengths, contact ESAB for more information.

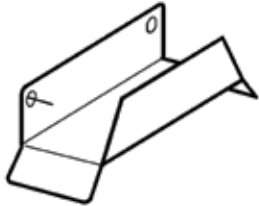
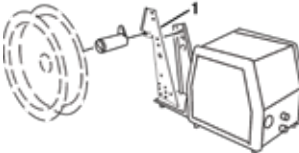

## Wire Feeder Accessories

 <p><b>Wheel Kit</b> Part Number: 0458707880 Increases the working radius from the power source. The wheel kit has four wheels and can also be placed to pivot on the power source.</p>	 <p><b>Lifting Eye</b> Part Number: 0458706880 Using this device, the feeder unit can be suspended in a swinging arm.</p>	 <p><b>60 lb Coil Extension Bracket</b> Part Number: 0459233880w For use with coil adaptor.</p>	 <p><b>Coil Adaptor</b> Part Number: 34323</p>
 <p><b>Strain Relief for Welding Torch</b> Part Number: 0457341881 Recommended in combination with wheel kit.</p>	 <p><b>Feeder Strain Relief for Connection Cables</b> Part Number: 0459234880</p>	 <p><b>Stabilizer Kit</b> Part Number: 0465509880 Warrior Trolley 1 Cylinder Must be used when MiniBoom</p>	 <p><b>Miggytrac/Railtrac Remote Adaptor for CAN feeders MA23, MA24, U6, U8, Plus</b> Part Number: 0459681880</p>
 <p><b>Steel Spool Cover</b> Part Number: 0459431880 12 in. (305 mm) spools.</p>	 <p><b>1 - Spool Holder</b> Part Number: 0458704880 <b>2- Adaptor for 11-lb (5 kg) Spool</b> Part Number: 0455410001</p>	 <p><b>Warrior Trolley Guide Pin Extension</b> Part Number: 0465508880 For use with Wheel Kit.</p>	 <p><b>Electrode Holder Assembly QD</b> Part Number: 21226</p>
 <p><b>Quick Connector Marathon Pac</b> Part Number: 0558002354 Allows connection of QCA Adaptor to Aristo Feed inlet.</p>	 <p><b>Cable and Torch Holder</b> Part Number: 0349303362</p>	 <p><b>60 lb Coil Extension Bracket</b> Part Number: 0459233880 For use with coil adaptor.</p>	 <p><b>Remote Connection Cable for CAN</b> Part Number: 0459960880 (Requires MTA or M1 10Prog CAN remote) CAN 4 pole - 10 pole 16.4 ft. (5 m).</p>

WIRE FEEDERS

## Wire Feeder Accessories

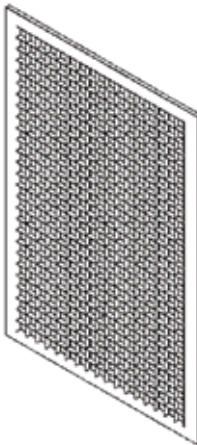
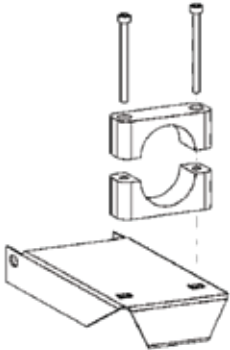
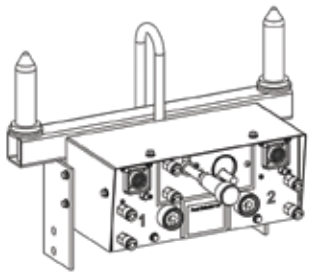
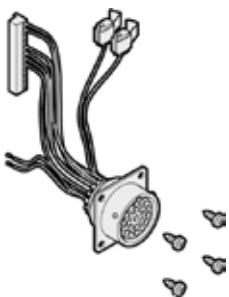
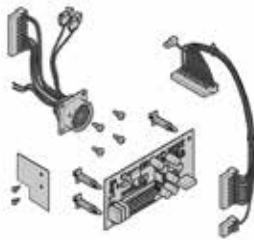
WIRE FEEDERS

 <p><b>Foot pedal T1 Foot CAN</b> Part Number: 0460315881 incl. 16.4 ft. (5 m) cable with 10 pole plug, for connection to the feeder with U6 panel.</p> <p>Part Number: 0460315880 incl. 16.4 ft. (5 m) cable with 12 pole plug, for connection to the feeder for U8<sub>2</sub> Plus.</p>	 <p><b>Air Filter</b> Part Number: 0349302252 Cleanable/reusable, optional filter. Extends time between required maintenance and protects components in harsh environments. For use with Origo Mig 4002c/5002cw/6502c.</p>	 <p><b>Power Source Strain Relief for Connection Cables</b> Part Number: 0349311700 Recommended when moving power supply frequently and use of long connection sets.</p>	 <p><b>Feed Selector</b> Part Number: 0349301152 Allows the use of the two 3004 feeds M0 with a U82 Plus on MIG 4002c/5002c/6502c.</p>
 <p><b>Remote Kit – WarriorFeed 304</b> Part Number: 0465451880 For use with Handheld Remote Unit M1</p>	 <p><b>Remote Kit Miggrac/Railtrac WarriorFeed 304</b> Part Number: 0465451881</p>	 <p><b>Quick Connector Bushing Marathon Pac</b> Part Number: 0558002354 Allows use of p/n 899F50 QCA Fitting.</p>	

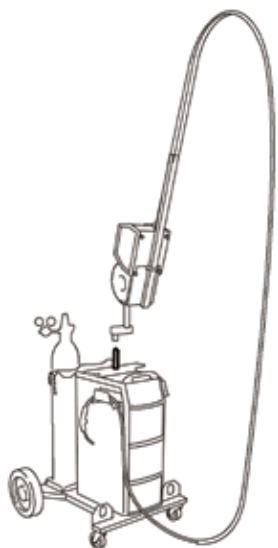

### MiniBoom Assembly

- Up to 25 ft. (7.6 m) working radius – effective area of over 1900 sqft. (579 m<sup>2</sup>)
- 350° working envelope
- Mounts easily to power source, inverter cart or stationary pedestal
- Adjustable boom length
- Adjustable counterbalance spring
- Feed 304/3004 only

Ordering Information	
MiniBoom for Spools (12")	0458705880
MiniBoom for Coils (18")	0458705882

*\*Use with accessories listed for Trolley/power source used.*



# Balanced Boom Assembly

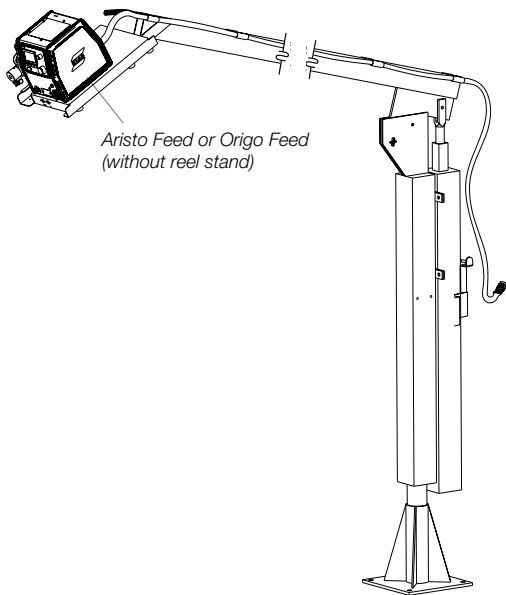

- Extends a 12 ft. (4 m) or 15 ft. (4.5 m) torch's reach from a 20 ft. (6 m) radius up to a 31 ft. (9.5 m) radius
- 350° envelope of operation in most uses
- Boom adjusts from 50° up to 6° down from horizontal position, can be used for tall weldments
- Fully balances feeder weight for fingertip control of feeder height, no lever jacking
- Mast has 6.5 ft. (2 m) clearance from floor to boom support pin
- Standard mounting directly to concrete floor
- Pallet and cart mounting options available
- Extremely rugged steel construction for years of continuous use
- Weld parameters easily adjustable on the standard feeder at the end of boom
- Wire spools mountable to mast or feed wire from Marathon Pac

## Ordering Information

8 ft. (2.4 m), B-8/FHD	0558004002	10 ft. (3 m), B-10/FHD	0558004006
12 ft. (3.6 m), B-12/FHD	0558003734	16.4 ft. (5 m), B-16/FHD	0558003737

## Options & Accessories

8 ft. (2.4 m), Plastic Trough	0558004004	10 ft. (3 m), Plastic Trough	0558004008
12 ft. (3.6 m), Plastic Trough	0558003447	16.4 ft. (5 m), Plastic Trough	0558003732
Boom mounting bracket <sup>1</sup>	0558005581	Feeder strain relief for torch <sup>1</sup>	0457341881
ERS conduit bushing support bracket <sup>2</sup>	37770	Spindle assembly <sup>3</sup>	948259
Coil adapter for 60-lb (27-kg) coils	34323	Pallet base <sup>4</sup>	37776
Welding cart with wheels <sup>5</sup>	37777	Inlet guide, 0.2-1 in. (4-30 mm), Marathon Pac <sup>6</sup>	0558002354

<sup>1</sup>For Origo Feed and Aristo Feed wire feeders.

<sup>2</sup>Used with spindle assembly #948259 (holds conduit inlet inline with spool).

<sup>3</sup>For mast mounted spools - requires 1/4 in. hardware.

<sup>4</sup>Requires anchoring to floor in-use.

<sup>5</sup>Use with 12 ft. maximum boom and 300+ lbs. power source.

<sup>6</sup>Accepts QCA adaptor #899F50.

Typical wire feeder

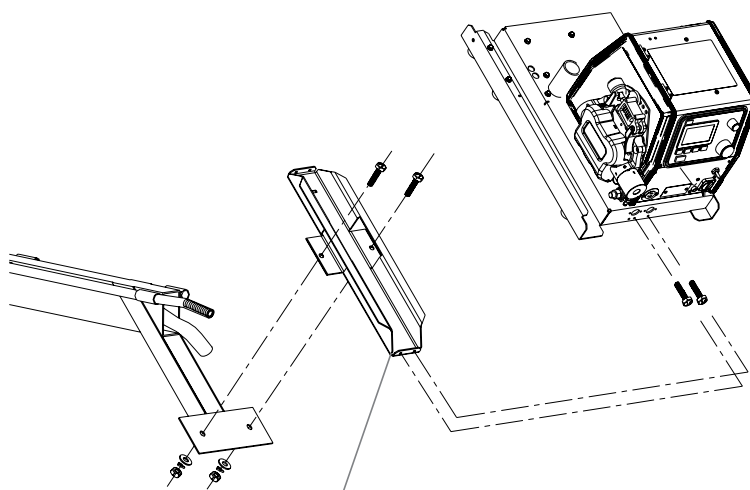

Typical wire feeder mounting bracket

## ES 95i

Portable DC Stick and Stick/TIG Welding Systems



- DC output for TIG welding stainless, mild steel, and chrome molys
- Lift TIG Start provides optimized TIG arc starting without the use of high frequency
- 90 A of output capable of welding 3/32 in. (2.4 mm) electrodes
- Fixed Hot Start & Arc Force for optimum Stick electrode performance
- Overload Protection shuts down the power source to protect the internal electrical components

### Specifications

Input Voltage	Welding Output TIG	Welding Output Stick	Current Range	
120 VAC, 1 ph, 50/60 Hz	85 A/13.4 V @ 25% Duty Cycle, 115 V, 15 A 95 A/13.8 V @ 20% Duty Cycle, 115 V, 20 A	60 A/22.4 V @ 45% Duty Cycle, 115 V, 15 A 90 A/23.6 V @ 20% Duty Cycle, 115 V, 20 A	10 – 95 A (TIG) 10 – 90 A (Stick)	
Supply Plug	Lead Cord Length	Open Circuit Voltage	Dimensions	Weight
NEMA 5-20P	10 ft. (3 m)	60 VDC	13 x 5.1 x 9 in. (330 x 130 x 230 mm)	9.7 lbs. (4.4 kg)

### Ordering Information

ES 95i Portable DC Stick Package	W1003209
ES 95i Portable DC Stick/TIG Package	W1003210

W1003210 Includes: all components from W1003209 plus 17V style TIG torch 3 m (10 ft.) and accessory kit with Victor Argon Flowgauge Regulator.

W1003209 Includes: ES 95i power supply, electrode holder with 4 m (13 ft.) lead, ground clamp with 3 m (10 ft.) lead, 15-20 A power adapter plug and cable, operator's manual and CD, 4 general purpose Stick electrodes (E6013), carry case.

### Options & Accessories

TIG Torch and Accessories, 17V Style, 10 ft. (3 m)	W4012500
Electrode Holder and Lead Assembly, 13 ft. (4 m), 25 mm	W7003106
Ground Clamp and Lead Assembly, 10 ft. (3 m), 25 mm	W7003105
Victor Argon Flow Gauge Regulator GF-250-50-580	0781-9411
Dinse Adapter, 50 mm Female to 25 mm Male	W4017500
Power Adapter, 120V 20A to 15A	W4013300
Small Toolbox Case	W4012801

# MiniArc 161LTS

The welder's choice for Stick/TIG welding



- Automatic Primary Select operates on either 115 V or 230 V and automatically configures to the primary input supplied
- Able to use cellulosic 6010 electrodes with ease
- 18 lbs. (13.6 kg) weight with adjustable shoulder strap and carrying case makes this unit portable and easy to carry directly to the job
- 5 A to 160 A current range for DC welding
- Hot Start, Arc Force and Lift Arc TIG are standard on all models

Specifications				
Input Voltage	Welding Output TIG	Welding Output Stick	Current Range	Efficiency @ Max Current
115 V, 1 ph, 50/60 Hz 230 V, 1 ph, 50/60 Hz	110 A/14.4 V @ 35% Duty Cycle (115 V) 60 A/12.4 V @ 100% Duty Cycle (115 V) 160 A/16.4 V @ 35% Duty Cycle (230 V) 88 A/16.4 V @ 100% Duty Cycle (230 V)	110 A/24.4 V @ 35% Duty Cycle (115 V) 60 A/22.4 V @ 100% Duty Cycle (115 V) 160 A/26.4 V @ 35% Duty Cycle (230 V) 88 A/23.5 V @ 100% Duty Cycle (230 V)	5 A – 110 A (115 V) 5 A – 160 A (230 V)	80%
Open Circuit Voltage	Power Factor @ Max Current	Dimensions	Weight	
80 V	0.73	15.75 x 5.75 x 10 in. (400 x 146 x 255 mm)	18 lbs. (8 kg)	

Ordering Information	
MiniArc 161LTS, 115/230 V, 1 ph, Stick	0558101694
MiniArc 161LTS, 115/230 V, 1 ph, Stick, w/case	0558011934
MiniArc 161LTS, 115/230 V, 1ph, Stick/TIG	0558101699
MiniArc 161LTS, 115/230 V, 1ph, Stick/TIG, w/case	0558102202

*Includes: power source with 10 ft. (3 m) power cord, 115/230V input power adapter cable, 10 ft. (3 m) heavy-duty ground cable and clamp, 10 ft. (3 m), heavy-duty electrode holder and cable, and sample pack of ESAB electrodes.  
GTAW Package also includes HW-17FV torch, R33 reg/flowmeter, and GTAW accessory kit.*

Options & Accessories	
Plug adaptor 2ft 115V Miniarc	0558007830
Plug adaptor 2ft 230V Miniarc	0558007829
Welding cable 200A, 16.4 ft. (5 m) OKC25	0700006882
Return cable 200A, 16.4 ft. (5 m) OKC25	0700006883
GTAW torch, 17FV, 20 ft. (6 m) & accessory kit	0558101723
HRF1425-580 Reg-FM W/CGA-032 Hose ftgs	0781-2809
GTAW torch accessory kit	999126
Carrying case	0558011935

STICK/TIG MACHINES

## ET 201i DC

Portable DC HF Stick/TIG system



- Stick, HF (high frequency) TIG, and Lift TIG welding capabilities in one integrated portable package with 200 A welding output
- DC output for TIG welding stainless, mild steel and chrome molys
- Preflow and postflow - preset values over shielding gas before and after the weld
- Downslope control eliminates cracking at the end of the weld and HF arc start provides non-contact TIG starting eliminating tungsten or material contamination
- Gas solenoid valve eliminates manual gas control on the torch
- 200 A of output capable of welding 3/32 - 5/32 in. (2.4 - 4.0 mm) electrodes and fixed hot start and adjustable arc force control for optimum Stick electrode performance

### Specifications

Input Voltage	Supply Voltage	Current Range	Max. Output	Rated kVA	Supply Plug	Lead Cord Length
120 VAC, 208/230 VAC 1 ph, 50/60 Hz	104 – 127 VAC, 115 V 187 – 253 VAC, 208/230 V	10 - 160 A (TIG) 10 - 125 A (Stick) 10 - 200 A (TIG/Stick)	200 A	5 kVA, 115 V 6 kVA, 208/230 V	NEMA 6-50P	10 ft. (3 m)
Welding Output			Open Circuit Voltage		Protection Class	
TIG (GTAW) welding output 40°C (104°F) 100 A/14 V @ 60% Duty Cycle, 115 V, 15 A 150 A/16 V @ 34% Duty Cycle, 115 V, 20 A 200 A/18 V @ 25% Duty Cycle, 230 V		Stick (SMAW) welding output 40°C (104°F) 70 A/22.8 V @ 70% Duty Cycle, 115 V, 15 A 100 A/24 V @ 25% Duty Cycle, 115 V, 20 A 200 A/28 V @ 20% Duty Cycle, 230 V		71 V		IP23S
				Dimensions L x W x H		Weight
				17.7 x 5.3 x 9 in. (450 x 135 x 230 mm)		21.6 lbs. (9.7 kg)

### Ordering Information

ET 201i DC TIG/Stick Package	W1003807
------------------------------	----------

*Includes: ET 201i DC power supply, 200 A electrode holder with 13 ft (4 m) lead, 200 A ground clamp with 10 ft (3 m) lead, 26 style TIG torch 12.5 ft (3.8 m) and accessory kit, Victor argon flowgauge regulator, gas hose, adapter plug from 230 V 50 A to 120 V 15 A circuits, operator's manual and CD, 4 general purpose stick electrodes (E6013), and carry case.*

### Options & Accessories

TIG Torch, 26 w/8 pin hand remotes, 12.5 ft. (3.8 m), 50 mm (2 in.) & accessory kit	W4013600
Electrode Holder 200A and Lead Assembly, 13 ft. (4 m), 25 mm	9110-1177
Ground Clamp 200 A and Lead Assembly, 10 ft. (3 m), 25 mm	9255-1140
Victor Argon Flow Gauge Regulator GF-250-50-580	0781-9411
Gas Hose, 3.8 m (12.5 ft.), Male 5/8-18UNF	W4013900
Foot control contactor on/off & current control w/8-pin male plug and 15 ft. (4.6 m) cable	600285
Power Adapter 230 V to 120 V, 15 A	W4014000
Large Toolbox Case	W4012802

# Renegade™ ES 300i & ET 300iP

## Multi-voltage, industrial Stick/TIG machines



[esab.com/renegade](http://esab.com/renegade)



- ES 300i has highest power-to-weight ratio in its class weighing in at 33 lbs. (15 kg) and producing 300 A at 40% duty cycle (3 ph)
- Small, lightweight system can virtually go anywhere on the jobsite; its three handle design makes it easy for transportation and maneuvering through manholes and other hard to reach areas
- ES 300i incorporates excellent performance with 6010 (cellulosic) electrodes and additional functionality to tailor Arc Force for a softer or crisper arc through a 6010 mode
- With an excellent TIG operational range from 5 to 300 A, you'll have the confidence to tackle a broad range of material thicknesses
- Intuitive Interface – the machine's digital readout display, along with large buttons with excellent feedback and controls, make it easy to set parameters and read them from a distance
- Cable Management – an integrated latch system helps control cables so they can be secured to the machine, making it easy to pack up and go
- ET300iP - Pulse HF TIG. 0.1 - 1000 pulse frequency range, the widest range in its category giving you maximum precision TIG welding capability including better arc control, penetration and increased travel speeds
- Air- and water-cooled packages available with easy, intuitive set-up for ET 300iP

### Specifications

Input Voltage	Welding Output TIG		Welding Output Stick		Current Range	Input Current Draw	Rated kVA
230 – 460 VAC 1 ph, 3 ph +/- 10% 50/60 Hz	300 A/20 V @ 40% Duty Cycle, 3 ph 250 A/20 V @ 60% Duty Cycle, 3 ph 200 A/18 V @ 100% Duty Cycle, 1/3 ph		300 A/30 V @ 40% Duty Cycle, 3 ph 250 A/30 V @ 60% Duty Cycle, 3 ph 200 A/28 V @ 100% Duty Cycle, 1/3 ph		5 – 200 A, 1 ph 5 – 300 A, 3 ph	10 A, 400 – 460 V 11 A, 380 V 20 A, 230 V	11.3 kVA
Open Circuit Voltage	Power Factor @ Max Current	Efficiency @ Max Current	Energy Save Mode	Lead Cord Length	Dimensions L x W x H	Weight	
48 V (32 V - VRD)	0.96	85% (TIG) 89% (Stick)	91 W	10 ft. (3 m)	ES 300i: 15.75 x 5.75 x 10 in. (400 x 146 x 255 mm)  ET 300iP: 18.1 x 7.9 x 12.6 in. (460 x 200 x 320 mm)	ES 300i: 18 lbs. (8 kg)  ET 300iP: 37.3 lbs. (16.9 kg) without cooler 59.3 lbs. (59.3 kg) with cooler	

STICK/TIG MACHINES

### Ordering Information

Renegade ES 300i	0445100881
Renegade ET 300iP Std Pkg	0445100921
Renegade ET 300iP TXH 201 13 ft. (4 m)	0558102564
Renegade ET 300iP TXH 201 26 ft. (7.9 m)	0558102565
Renegade ET 300iP TXH 201 13 ft. (4 m), Foot Control 16.5 ft. (5 m)	0558102566
Renegade ET 300iP TXH 201 26 ft. (7.9 m), Foot Control 32 ft. (9.8 m)	0558102567
Renegade ET 300iP TXH 252w 13 ft. (4 m), Foot Control 16.5 ft. (5 m) Water-Cooled	0558102568

Standard package includes power supply, shoulder strap, 10 ft. (3 m) input cable, 2 x OKC 50mm connectors (packages do not contain work cables or electrode cables). All TXH 201 packages include everything in the standard package plus TXH 201 TIG torch with on/off switch, GTAW Accessory regulator/flowmeter w/gas hose. Foot control packages include everything in the TXH 201 package plus ER1F foot control 16.5 ft. (5 m). TXH 252w package includes power supply, shoulder strap, 10 ft. (3 m) input cable, 2 x OKC 50mm connectors, EC 1000 water cooler, TIG torch with on/off switch, ER1F foot control, GTAW Accessory kit, regulator/flowmeter w/gas hose and two-wheeled trolley.

## Renegade™ ES 300i & ET 300iP Accessories

Options & Accessories	
<b>Renegade ES 300i</b>	
Electrode Cable T316 15 ft. (5 m) 2/0	0558102319
Work Cable GC-500 15 ft. (5 m) 4/0	0558102318
OKC 50 male cable plug	13733936
ER 1 Remote control. 16.4 ft (5 m) interconnection cable, 6 pin,	0445536881
ER 1 F Foot pedal 16.4 ft (5 m) interconnection cable, 6 pin,	0445550881
26V-12R TIG Torch 12.5 ft. (3.8 m)	Q26V-12R
TIG Torch Adapter	QDA-26R
Interconnection cable, 6 pin, 16.4 ft (5 m) for ER 1	0445280880
Interconnection cable, 6 pin, 32.8 ft (10 m) for ER 1	0445280881
Interconnection cable, 6 pin, 16.4 ft (5 m) for ER 1 F	0445254880
Interconnection cable, 6 pin, 32.8 ft (10 m) for ER 1 F	0445254881
<b>Renegade ET 300iP</b>	
Shoulder strap	0445197880
Trolley 2-wheel for Renegade	0460330881
TXH 201 TIG Torch 13 ft. (4 m)	0700300552
TXH 201 TIG Torch 26 ft. (8 m)	0700300555
TXH 252w TIG Torch 13 ft. (4 m)	0700300855
TXH 252w TIG Torch 26 ft. (8 m)	0700300856
EC 1000 Water-Cooler	0445045880
ER 1 Remote Control incl. 16.4 ft. (5 m) cable and 6-pin connector	0445536881
ER 1 Remote Control incl. 33 ft. (10 m) cable and 6-pin connector	0445536882
ER 1 Remote Control incl. 82 ft. (25 m) cable and 6-pin connector	0445536883
ER 1F Foot Control incl. 16.4 ft. (5 m) cable and 6-pin connector	0445550881
ER 1F Remote Control incl. 33 ft. (10 m) cable and 6-pin connector	0445550882

STICK/TIG  
MACHINES



Trolley 2-wheel (0460330881)

# ET 141i AC/DC

Portable AC/DC HF TIG/Stick welding system



- AC and DC output for aluminum and non-ferrous alloys, stainless, mild steel and chrome moly
- AC Frequency preset sets the frequency of the AC square wave and Wave Balance sets the penetration to cleaning ratio when welding on aluminum
- Lift TIG Start provides optimized TIG arc starting without the use of high frequency
- Preflow and postflow presets controls the shielding gas before and after the weld
- Hot Start ensures good arc starting when Stick welding

## Specifications

Input Voltage	Supply Voltage	Current Range	Max. Output	Rated kVA	Supply Plug	Lead Cord Length
Nominal 120 VAC 1 ph, 50/60 Hz	108-132 VAC	10-140 A	140 A	5 kVA @ 180 A	NEMA 5-20P	10 ft. (3 m)
Welding Output			Open Circuit Voltage	Protection Class		
TIG (GTAW) welding output 40°C (104°F) 140 A/15.6 V @ 20% Duty Cycle 75 A/13 V @ 60% Duty Cycle 60 A/12.4 V @ 100% Duty Cycle		Stick (SMAW) welding output 40°C (104°F) 90 A/23.6 V @ 20% Duty Cycle	77.6 VDC/92.8 VAC	IP23S		
			Dimensions L x W x H	Weight		
			17 x 9.45 x 15.75 in. (432 x 240 x 400 mm)	48.4 lbs. (22 kg)		

## Ordering Information

ET 141i AC/DC TIG/Stick System	W1006311
ET 141i AC/DC TIG/Stick System with Foot Control	W1006313
ET 141i AC/DC TIG/Stick System with Foot Control & Basic Utility Cart	W1006314

W1006311 Includes: ET 141i AC/DC power supply, argon flow gauge regulator and 12.5 ft. (3.8 m) hose, TIG torch and accessories, 17 Style, 13 ft. (4 m), 4 general purpose stick electrodes (E6013), power adapter 120V 20A to 15A, 10 ft. (3 m) power cord and NEMA 5-20P 120 VAC plug, 150A electrode holder with 13 ft. (4 m) lead, 150A ground clamp with 3 m (10 ft.) lead, operator's manual.

W1006313 Includes: all components from W1006311 plus foot control with 15 ft. (4.6 m) cable.

W1006314 Includes: all components from W1006311 plus foot control with 15 ft. (4.6 m) cable and basic utility cart.

## Options & Accessories

TIG Torch and Accessories, 17 Style, 13 ft. (4 m)	W4012701
Electrode Holder 200A and Lead Assembly, 13 ft. (4 m), 50 mm	1201-9577
Ground Clamp 200 A and Lead Assembly, 10 ft. (3 m), 50 mm	1201-9585
Victor Argon Flow Gauge Regulator GF-250-50-580	0781-9411
Gas Hose, 12.5 ft. (3.8 m), Male 5/8-18UNF	W4013900
Foot Control, 15 ft. (4.6 m) cable and 8-pin Male Plug	W4013200
Power adapter, 120V 20A to 15A	W4013300
Basic Utility Cart, max 7 in. (177.8 mm) diameter cylinder	W4014700

## ET 186i AC/DC

Portable AC/DC HF TIG/Stick welding system



- AC and DC output for aluminum and non-ferrous alloys, stainless, mild steel and chrome moly
- HF Arc Start: provides non-contact arc starting that eliminates tungsten or material contamination
- Pulse: changes the weld current from high to low at a specified frequency, reduces heat input on thin material (0.5 Hz - 200 Hz)
- AC Frequency: adjustable frequency of the AC square wave when welding on aluminum for optimized set up (15 Hz - 150 Hz)
- Wave Balance: adjustable for optimized penetration or cleaning action when welding on aluminum

### Specifications

Input Voltage	Supply Voltage	Current Range	Max. Output	Rated kVA	Supply Plug	Lead Cord Length
208/230 VAC 1 ph, 50/60 Hz	187 - 253 VAC	10 - 200 A (TIG) 10 - 170 A (Stick)	200 A	9.5 kVA @ 200 A	NEMA 6-50P	10 ft. (3 m)
Welding Output			Open Circuit Voltage	Protection Class		
TIG (GTAW) welding output 40°C (104°F) 200 A/18 V @ 20% Duty Cycle 116 A/14.6 V @ 60% Duty Cycle 90 A/13.6 V @ 100% Duty Cycle		Stick (SMAW) welding output 40°C (104°F) 170 A/26.8 V @ 15% Duty Cycle 100 A/24 V @ 60% Duty Cycle 80 A/23.2 V @ 100% Duty Cycle	70.3 VDC/50 VAC	IP23S		
			Dimensions L x W x H	Weight		
			18.7 x 9.5 x 15.8 in. (475 x 240 x 400 mm)	48.4 lbs. (22 kg)		

### Ordering Information

ET 186i AC/DC TIG/Stick System	W1006301
ET 186i AC/DC TIG/Stick System with Foot Control	W1006303
ET 186i AC/DC TIG/Stick System with Foot Control & Basic Utility Cart	W1006304

*Includes: ET 186i AC/DC inverter power supply, electrode holder with 13 ft. (4 m) lead, work clamp with 10 ft. (3 m) lead, 26 TIG torch 12.5 ft. (3.8 m) lead with integrated controls and accessories, input power cable/plug 9 ft. (2.75 m), Victor argon flowgauge regulator, 12.5 ft. (3.8 m) hose, electrode bonus, shoulder strap and operating manual/CD.  
Foot Control package includes: all components from W1006301 plus foot control with 15 ft. (4.6 m) cable.  
Foot Control/Utility Card package includes: all components from W1006301 plus foot control with 15 ft. (4.6 m) cable and basic utility cart.*

### Options & Accessories

TIG Torch and Accessories (required for TIG welding)	W4013600
Electrode Holder 200A and Lead Assembly, 13 ft (4 m), 25 mm	9110-1177
Ground Clamp 200 A and Lead Assembly, 10 ft (3 m), 25 mm	9255-1140
Victor Argon Flow Gauge Regulator GF-250-50-580	0781-9411
Gas Hose, 12.5 ft (3.8 m), Male 5/8-18UNF	W4013900
Foot Control, 15 ft (4.6 m) cable and 8-pin Male Plug	W4013200
Basic Utility Cart, max 7 in. (177.8 mm) diameter cylinder	W4014700



# ET 220i AC/DC

## HF TIG inverter power supply



- High output, full digital control, AC/DC, inverter power supply for precision TIG and Stick welding with expanded input voltage capabilities for maximum flexibility
- HF TIG and Liftarc TIG start with rapid pulse output
- Superior, true square wave output combined with advanced balance and cleaning features to deliver unbeatable welding performance with extended tungsten life on aluminum and magnesium alloys without the need for continuous high frequency
- Automatic downslope, pulse, repeat (latch) function, memory function and automatic gas management
- Embedded microprocessor with digital controls, tiptronic memory functions and robust aluminum metal case

### Specifications

Input Voltage	Current Range	Effective Input Current	Max. Input Current
208-230/460 VAC +/-15% 1/3 ph, 50/60 Hz	TIG 1 ph: 5 - 200 A TIG 3 ph: 5 - 220 A	Stick 1 ph: 10 - 150 A Stick 3 ph: 10 - 170 A	1ph: 37.3 A (208 V), 33.7 A (230 V), 18.1 A (460 V) 3ph: 24.5 A (208 V), 22.1 A (230 V), 11.9 A (460 V)
Welding Output		Open Circuit Voltage	Protection Class
TIG (GTAW) welding output 40°C (104°F) 200 A/18.8 V @ 45% Duty Cycle, 1 ph 180 A/17.2 V @ 60% Duty Cycle, 1 ph 220 A/18.8 V @ 40% Duty Cycle, 3 ph 160 A/16.4 V @ 100% Duty Cycle, 3 ph		<113 V (VRD active)	IP23S
Stick (SMAW) welding output 40°C (104°F) 150 A/26 V @ 40% Duty Cycle, 1 ph 170 A/26.8 V @ 40% Duty Cycle, 3 ph 140 A/25.6 V @ 60% Duty Cycle, 1/3 ph		Dimensions L x W x H	Weight
		19 x 7.25 x 13 in. (483 x 185 x 326 mm)	29.5 lbs. (13.4 kg)

### Ordering Information

ET 220i AC/DC power source	W1009300
ET 220i AC/DC HF TIG	W1009301
ET 220i AC/DC HF TIG with trolley	W1009302

HF TIG package includes: inverter power source, 200A air cooled TIG torch with accy's., work and electrode lead, gas hose and flowmeter/regulator, operator's manual and set-up DVD, primary cable and Dinse plugs.

HF TIG with trolley package includes: inverter power source, 200A air cooled TIG torch with accy's., work and electrode lead, gas hose and flowmeter/regulator, industrial trolley, operator's manual and set-up DVD, primary cable and Dinse plugs.

## ET 301i AC/DC

HF TIG Inverter Power Supply



- High output, full digital control, AC/DC, inverter power supply for precision TIG and Stick welding with expanded input voltage capabilities for maximum flexibility
- High frequency start, Lift Arc TIG start, automatic downslope, pulse, repeat (latch) function, memory function and automatic gas management
- Automatic input voltage selection – operates on 208-230/460V single or three phase
- Lightweight and portable at 35.9 lbs. (16.3 kg)
- Tiptronic - 100 memory functions
- Robust aluminum metal case

### Specifications

Input Voltage	Current Range	Effective Input Current	Max. Input Current
208 – 230/460 VAC +/-15%, 1/3 ph, 50/60 Hz	TIG 1 ph: 5 – 200 A TIG 3 ph: 5 – 300 A	Stick 1 ph: 10 – 150 A Stick 3 ph: 10 – 200 A	1 ph: 37.3 A (208 V), 33.7 A (230 V), 18.1 A (460 V) 3 ph: 23.8 A (208 V), 21.6 A (230 V), 11.6 A (460 V)
<b>Welding Output</b>		<b>Open Circuit Voltage</b>	<b>Protection Class</b>
TIG (GTAW) welding output 40°C (104°F) 200 A/18 V @ 60% Duty Cycle, 1 ph 300 A/22 V @ 30% Duty Cycle, 3 ph 170 A/16.8 V @ 100% Duty Cycle, 1/3 ph		<113 V (VRD active)	IP23S
Stick (SMAW) welding output 40°C (104°F) 150 A/26 V @ 100% Duty Cycle, 1 ph 200 A/28 V @ 60% Duty Cycle, 3 ph 165 A/26.6 V @ 100% Duty Cycle, 3 ph		<b>Dimensions L x W x H</b>	<b>Weight</b>
		19 x 7.25 x 13 in. (483 x 185 x 326 mm)	35.9 lbs. (16.3 kg)

### Ordering Information

ET 301i AC/DC power source	W1009400
ET 301i AC/DC HF TIG Water-Cooled	W1009401

HF TIG package includes: inverter power source, 300A WC TIG torch w/Accy's., water recirculator, work and electrode lead, gas hose and flowmeter / regulator, industrial cart, operator's manual & set-up DVD, primary cable and Dinse plugs.



## ET 220i & 301i AC/DC Accessories

Options & Accessories	
TIG Torch, 26 w/8 pin hand remotes, 12.5 ft. (3.8 m), 2 in. (50 mm) & accessory kit	W4013600
TIG Torch, 18, 25 ft. (7.6 m), water-cooled, 2 in. (50 mm) & accessory kit	W4013604
Tweco 200A electrode holder & lead assy. 13 ft. (4 m) length, 2 in. (50 mm) Dinse	91101177
Tweco 200A ground clamp & lead assy. 10 ft. (3 m) length, 2 in. (50 mm) Dinse	92551140
Victor ESS3-RG-580 EDGE Argon flowgauge regulator	0781-5120
Gas hose, 12.5 ft. (3.8 m) length, male 5/8 in. -18unf gas fittings	W4013900
Foot control contactor on/off & current control w/8-pin male plug and 15 ft. (4.6 m) cable	600285
Foot control contactor on/off & current control w/8-pin male plug and 25 ft. (7.6 m) cable	10-4016
HP-100 hand held remote control pendant	10-4014
Torch mounted contactor on/off w/8-pin male plug and 15 ft. (4.6 m) cable	10-4006
Torch mounted contactor on/off w/8-pin male plug and 25 ft. (7.6 m) cable	10-4007
Torch mounted contactor on/off & current control w/8-pin male plug & 15 ft. (4.6 m) cable, fits CK9 style handle	10-4008
Torch mounted contactor on/off & current control w/8-pin male plug & 15 ft. (4.6 m) cable, fits CK17 style handle	10-4009
Torch mounted contactor on/off & current control w/8-pin male plug & 15 ft. (4.6 m) cable, fits CK26 style handle	10-4010
Torch mounted contactor on/off & current control w/8-pin male plug & 25 ft. (7.6 m) cable, fits CK9 style handle	10-4011
Torch mounted contactor on/off & current control w/8-pin male plug & 25 ft. (7.6 m) cable, fits CK17 style handle	10-4012
Torch mounted contactor on/off & current control w/8-pin male plug & 25 ft. (7.6 m) cable, fits CK26 style handle	10-4013
Torch mounted contactor on/off & current control w/8-pin plug & 15 ft. (4.6 m) cable	600296
Torch mounted contactor on/off & current control w/8-pin plug & 25 ft. (7.6 m) cable	600297
110VAC water recirculator	W4001303
Water recirculator to power supply interface cable	W4001350
Industrial trolley (running gear/cylinder rack)	W4010003



## Heliarc® 281i & 353i AC/DC

For quality TIG/Stick applications.



- Designed for quality TIG (GTAW) and Stick (SMAW) applications in all types of material
- Cost effective inverter technology means increased energy efficiency and more power from a lighter, smaller, and more portable unit
- Easy-to-control arc heat input provides high quality welds with an intuitive interface for easy setup and adjustment
- Digital controls ensure high accuracy and repeatability
- Live TIG is ideal in places where high-frequency (HF) is not allowed
- AC Pulsing up to 2 Hz makes Heliarc® ideal for welding thin aluminum material
- Easily store up to 60 parameter sets for quick changes while working

### Specifications - Heliarc 281i AC/DC

Input Voltage	Current Range		Amps Input at Rated Load TIG	Amps Input at 250 A TIG	Power Factor @ Max Current TIG	Rated kVA
208 – 230 V, 1 ph, 50/60 Hz	TIG AC/DC: 4 – 280 A	Stick AC/DC: 4 – 250 A	47 A	38 A	0.80	10.5 kVA (TIG) / 12 kVA (Stick)
Gas Pre-Flow	Gas-Post Flow	Slope Down	Frequency AC	AC Balance	DC Pulse Mode Frequency	AC Pulse Mode Frequency
0.1 – 25 sec	0.1 – 30 sec	0.1 – 10 sec	20 – 200 Hz	10 – 90%	0.4 – 300 Hz	0.4 – 2 Hz
Pulse Duty (pulse time/background time)		Background Current % of Main		Start/Crater Current (4 stroke) % of Main		Protection Class
30 – 65%		10 – 90 A		10 – 90 A		IP21S
Welding Output			Dimensions L x W x H		Weight	
TIG (GTAW) AC/DC 250 A @ 100% Duty Cycle 270 A @ 60% Duty Cycle 280 A @ 50% Duty Cycle		Stick (SMAW) AC/DC 200 A @ 100% Duty Cycle 220 A @ 60% Duty Cycle, 3 ph 250 A @ 40% Duty Cycle, 3 ph		23.6 x 11.8 x 24.4 in. (600 x 300 x 620 mm)		110 lbs. (50 kg)

### Specifications - Heliarc 353i AC/DC

Input Voltage	Current Range		Amps Input at Rated Load TIG	Amps Input at 250 A TIG	Power Factor @ Max Current TIG	Rated kVA
460 V, 3 ph, 50/60 Hz	TIG AC/DC: 4 – 350 A	Stick AC/DC: 4 – 350 A	16.6 A	12.5 A	0.80	14.5 kVA (TIG) 19 kVA (Stick)
Gas Pre-Flow	Gas-Post Flow	Slope Down	Frequency AC	AC Balance	DC Pulse Mode Frequency	AC Pulse Mode Frequency
0.1 – 25 sec	0.1 – 30 sec	0.1 – 10 sec	20 – 200 Hz	10 – 90%	0.4 – 300 Hz	0.4 – 2 Hz
Pulse Duty (pulse time/background time)		Background Current % of Main		Start/Crater Current (4 stroke) % of Main		Protection Class
30 – 65%		10 – 90 A		10 – 90 A		IP21S
Welding Output			Dimensions L x W x H		Weight	
TIG (GTAW) AC/DC 280 A @ 100% Duty Cycle 300 A @ 60% Duty Cycle 350 A @ 45% Duty Cycle		Stick (SMAW) AC/DC 220 A @ 100% Duty Cycle 240 A @ 60% Duty Cycle, 3 ph 350 A @ 20% Duty Cycle, 3 ph		23.6 x 11.8 x 24.4 in. (600 x 300 x 620 mm)		110 lbs. (50 kg)

### Ordering Information

Heliarc 281i, 208-230V, Power Source Only	0558101696	Heliarc 281i, 230V, Basic Pkg	0558101704
Heliarc 281i, 230V, Air Cooled, TXH 151F, Ready-to-Weld	0558101706	Heliarc 281i, 230V, Air Cooled, TXH 201F, Ready-to-Weld	0558101707
Heliarc 281i, 230V, Water Cooled, TXH 251F, Ready-to-Weld	0558101708	Heliarc 281i, 230V, Water Cooled, TXH 401F, Ready-to-Weld	0558101709
Heliarc 353i, 460V, Power Source Only	0558101697	Heliarc 353i, 460V, Basic Pkg	0558101705
Heliarc 353i, 460V, Water Cooled, TXH 251F, RTW	0558101710	Heliarc 353i, 460V, Water Cooled, TXH 401F, Ready-to-Weld	0558101711

RTW - Ready-to-Weld Packages include: power source, 26 ft. (8 m) torch, foot control, work cable, regulator/flowmeter Ar/CO<sub>2</sub>, and cart.  
Basic Packages include: power source, cooler, 2x-cable plugs, and coolant.

# Heliarc® 281i & 353i AC/DC Accessories

## Options & Accessories

### TIG Torches

TXH 151F, 26 ft. (8 m) OKC50	0700300547
TXH 201F, 26 ft. (8 m) OKC50	0700300557
TXH 251wF, 26 ft. (8 m) OKC50	0700300564
TXH 401w, 26 ft. (8 m) OKC50	0700300567
TXH 151, Air-Cooled, OKC50, 26 ft. (8 m), wheel remote	0700300657
TXH 201, Air-Cooled, OKC50, 26 ft. (8 m), wheel remote	0700300658
TXH 251w, 26 ft. (8 m), wheel remote	0700300659
TXH 401w, 26 ft. (8 m), wheel remote	0700300660
TXH 151, Air-Cooled, OKC50, 26 ft. (8 m), flex wheel remote	0700300661
TXH 201, Air-Cooled, OKC50, 26 ft. (8 m), flex wheel remote	0700300662
TXH 251w Flex, 26 ft. (8 m), wheel remote	0700300663

### TIG Torch Accessory Kits

TXH-151/201	999126
TXH-251w	999127
TXH-401w	0558101886

### Additional Options & Accessories

Water cooler module	0558101703
Coolant, 1 gal. (3.8 L)	0560950312
Cart kit (required with water cooler module 0558101703)	0558101702
Foot control FC-5C, 30 ft. (9 m)	0558004234
Electrode Cable T316 15 ft. (5 m) 2/0	0558102319
Quick connect "T", 1 male/2 female fittings	0365557001
Quick lock connector male, 1/0 to 2/0 cable	0160360881
Quick lock connector female, 1/0 to 2/0 cable	13735632
Quick lock connector male, 1/0 to 4/0 cable	0160360882
Quick lock connector female, 1/0 to 4/0 cable	13735631
Work Cable GC-500 15 ft. (4.5 m) 4/0	0558102318

STICK/TIG MACHINES



## EASY FIND GUIDE - MIG Gun Selection Guide



Wire Diameter	Amperage Range												Recommended	Alternate		
	30	100	150	200	250	300	350	400	450	500	550	600			650	
Solid Wire - Mild Steel and Stainless Steel	.023" - .030" (0.6 - 0.8 mm)			CO <sub>2</sub>											Fusion 180, Mini-MIG 160, VELOCITY2 Mini-MIG 160	VELOCITY2 Classic No. 1, Classic No. 1
	.035" (0.9 mm)			CO <sub>2</sub>											Fusion 180, VELOCITY2 Spray Master SMV250, Spray Master 250	VELOCITY2 Classic No. 2, Classic No. 2, Smoke Master 250, Compact Eliminator 250
	.045" (1.2 mm)			CO <sub>2</sub>											VELOCITY2 Spray Master SMV350, Spray Master 350, VELOCITY2 Classic No. 4, Classic No. 4	VELOCITY2 Supra XT 400, Supra XT 400, Smoke Master 450
	.052" (1.3 mm)														VELOCITY2 Spray Master SMV450, Spray Master 450, VELOCITY2 Classic No. 4, Classic No. 4	VELOCITY2 Supra XT 400, Supra XT 400, Smoke Master 450
	1/16" (1.6 mm)														VELOCITY2 Spray Master SMV450, Spray Master 450, VELOCITY2 Classic No. 5, Classic No. 5	PulseMaster 500 Water-Cooled, Standard Water-Cooled 600

Wire Diameter	Amperage Range												Recommended	Alternate		
	30	100	150	200	250	300	350	400	450	500	550	600			650	
Flux Cored Wire	.030" (0.8 mm)														Fusion 180, Mini-MIG 160, VELOCITY2 Mini-MIG 160	VELOCITY2 Classic No. 1, Classic No. 1
	.035" (0.9 mm)														Fusion 180, VELOCITY2 Spray Master SMV250, Spray Master 250	VELOCITY2 Classic No. 2, Classic No. 2, Smoke Master 250, Compact Eliminator 250
	.045" (1.2 mm)														VELOCITY2 Spray Master SMV350, Spray Master 350, VELOCITY2 Classic No. 4, Classic No. 4	VELOCITY2 Supra XT 400, Supra XT 400, Smoke Master 450
	.052" (1.3 mm)														VELOCITY2 Spray Master SMV450, Spray Master 450, VELOCITY2 Classic No. 4, Classic No. 4	VELOCITY2 Supra XT 400, Supra XT 400, Smoke Master 450
	1/16" - 5/64" (1.6 - 2.0 mm)														VELOCITY2 Spray Master SMV450, Spray Master 450, VELOCITY2 Classic No. 5, Classic No. 5	PulseMaster 500 Water-Cooled, Standard Water-Cooled 600
	3/32" (2.4 mm)														VELOCITY2 Classic No. 6, Classic No. 6	VELOCITY2 Classic No. 5, Classic No. 5

\*Flux Cored SEFC Series MIG Guns are to be used only with Self-Shielded wire

Wire Diameter	Amperage Range												Recommended	Alternate		
	30	100	150	200	250	300	350	400	450	500	550	600			650	
Solid Wire - Aluminum	.030" (0.8 mm)														Spool Gun 160 & 200, Fusion 180	VELOCITY2 Classic No. 1, Classic No. 1
	.035" (0.9 mm)														Spool Gun 200, VELOCITY2 Spray Master 250, Spray Master 250	VELOCITY2 Classic No. 2, Classic No. 2
	3/64" (1.2 mm)														VELOCITY2 Spray Master SMV350, Spray Master 350, VELOCITY2 Classic No. 3, Classic No. 3	VELOCITY Spray Master SMV450, VELOCITY2 Classic No. 4, Classic No. 4
	1/16" (1.6 mm)														VELOCITY2 Spray Master SMV450, Spray Master 450	PulseMaster 500 Water-Cooled
	3/32" (2.4 mm)															

When welding with aluminum wire, standard MIG gun length of 12 ft should not be exceeded and conduit liners/contact tips made specifically for aluminum wires should be used.

# EASY FIND GUIDE - MIG Gun Selection Guide



Tweco MIG Gun	Amperage Range	Available Lengths ft (m)	Handle Design	Cablehoz Connection	Rear End Connector Options	Air-Cooled/ Water-Cooled	Special Features
Spray Master® Series	250, 350, 450	10, 12, 15, 20, 25 ft (3, 3.7, 4.6, 6.1, 7.6 m)	Small & Ergonomic	Crimped	Tweco, Miller®, Lincoln®, Euro-Kwik	Air	Heavy Duty Front End Consumables
VELOCITY2™ Spray Master® Series	250, 350, 450	10, 12, 15, 20, 25 ft (3, 3.7, 4.6, 6.1, 7.6 m)	Small & Ergonomic	Crimped	Tweco, Miller, Lincoln, Euro-Kwik	Air	Heavy Duty Front End Consumables
Classic® No. Series	180, 200, 300, 400, 500, 600	10, 12, 15, 20, 25 ft (3, 3.7, 4.6, 6.1, 7.6 m)	Oval/Paddle Contour	Mechanical	Tweco, Miller, Lincoln, Euro-Kwik	Air	Wide Range of Front End Consumables
VELOCITY2™ Classic® No. Series	180, 200, 300, 400, 500	10, 12, 15, 20, 25 ft (3, 3.7, 4.6, 6.1, 7.6 m)	Oval/Paddle Contour	Mechanical	Tweco, Miller, Lincoln, Euro-Kwik	Air	Wide Range of Front End Consumables
Fusion® Series	180	10, 12, 15 ft (3, 3.7, 4.6 m)	Small & Ergonomic	Crimped	Tweco, Miller, Lincoln, Euro-Kwik	Air	Longer Life Velocity Consumables
Compact Eliminator®	250, 450	10, 12, 15, 20, 25 ft (3, 3.7, 4.6, 6.1, 7.6 m)	Small & Ergonomic	Crimped	Tweco, Miller, Euro-Kwik	Air	Ball & Socket design conductor tube & cam style locking contact tips
Mini-MIG	160	10, 12, 15 ft (3, 3.7, 4.6 m)	Straight	Mechanical	Tweco, Miller, Lincoln, Euro-Kwik	Air	Wide Selection of Front End Consumables Available
VELOCITY2™ Mini-MIG	160	10, 12, 15 ft (3, 3.7, 4.6 m)	Straight	Mechanical	Tweco, Miller, Lincoln, Euro-Kwik	Air	Wide Selection of Front End Consumables Available
Supra® XT	400	15 ft (4.6 m)	Straight	Mechanical	Tweco, Miller, Lincoln	Air	Top Trigger Capability
VELOCITY2™ Supra® XT	400	15, 25 ft (4.6, 7.6 m)	Straight	Mechanical	Tweco, Miller, Lincoln	Air	Top Trigger Capability
Smoke Master® Series	250, 450	15 ft (4.6 m)	Ergonomic	Crimped	Tweco, Miller, Lincoln	Air	Fume Extraction Cam-Style Contact Tips
Flux Cored SEFC Series	450	10, 15 ft (3, 4.6 m)	Straight	Crimped	Tweco, Miller, Lincoln	Air	Galvanized Steel Inner Core Tube Cablehoz Design
Spool Gun Series	160, 200	12, 25 ft (3.7, 7.6 m)	Pistol Grip	Mechanical	Dinse Lug	Air	Accepts Standard 4" Spools Rotatable Wire Spool Housing
PulseMaster® Series	400, 500	12, 25 ft (3.7, 7.6 m)	Ergonomic	Crimped	Tweco	Water	Smart Option or Standard
Standard Water-Cooled	600	15 ft (4.6 m)	Ergonomic	Crimped	Tweco	Water	Inert Gas Style Fitting

For Special MIG gun configurations, including special consumables, please contact Tech Service and Support.

Adapter kits are available to fit Tweco rear connection to most wire feeders.

Some Lincoln wire feeders are assembled with their K1500-2 gun receiving bushing that will accept Tweco Style MIG Guns direct from the factory. Control wire (2060-2137) must be ordered separately.

Miller is a registered trademark of Illinois Tool Works, Inc. Lincoln is a registered trademark of Lincoln Electric Co. The aforementioned registered trademarks are in no way affiliated with Tweco. Tweco is registered trademark of ESAB.

MIG GUNS & TIG TORCHES

## Tweco Spray Master 250 Amp MIG Gun

For light/medium-duty fabrication



Standard Options Include:

- Rear Connector and Knucklehead Flexible Conductor Tube
- Standard Conductor Tube – (1630-1189) on all guns up to 15 ft. (4.6 m), (1630-1188) on all guns over 15 ft. (4.6 m)
- Conduit Liner – 42 Series

Specifications					
Rated Output	Gas	Wire Size	Cooled	Process	Application Usage
250 A @ 80% duty cycle	Mixed	up to .045 in. (1.2 mm)	Air	GMAW, AI, FCAW	light/medium-duty fabrication

Ordering Information						
Tweco Style Rear Connector		Miller Style Rear Connector		Euro-Kwik Style Rear Connector		
12 ft. (3.6 m), .045 in. (1.2 mm)	1023-1101	10 ft. (3 m), .045 in. (1.2 mm)	1023-1110	12 ft. (3.6 m), .045 in. (1.2 mm)	1023-1126	
15 ft. (4.6 m), .045 in. (1.2 mm)	1023-1102	12 ft. (3.6 m), .045 in. (1.2 mm)	1023-1111	15 ft. (4.6 m), .045 in. (1.2 mm)	1023-1127	
20 ft. (6.1 m), .045 in. (1.2 mm)	1023-1103	15 ft. (4.6 m), .045 in. (1.2 mm)	1023-1112	25 ft. (7.6 m), .045 in. (1.2 mm)	1023-1133	
25 ft. (7.6 m), .045 in. (1.2 mm)	1023-1108	20 ft. (6.1 m), .045 in. (1.2 mm)	1023-1113	Lincoln Style Rear Connector		
Tweco Style (8-pin) Rear Connector		25 ft. (7.6 m), .045 in. (1.2 mm)	1023-1118	12 ft. (3.6 m), .045 in. (1.2 mm)	1023-1136	
12 ft. (3.6 m), .045 in. (1.2 mm)	1023-1141					
15 ft. (4.6 m), .045 in. (1.2 mm)	1023-1140					

## Tweco Spray Master 350 Amp MIG Gun

For medium/heavy-duty fabrication



Standard Options Include:

- Dual Schedule On/Off Control, Rear Connector and Knucklehead
- Flexible Conductor Tube
- Standard Conductor Tube – (1630-1189) on all guns up to 15 ft. (4.6 m), (1630-1188) on all guns over 15 ft. (4.6 m)
- Conduit Liner – 44 Series

Specifications					
Rated Output	Gas	Wire Size	Cooled	Process	Application Usage
350 A @ 80% duty cycle	Mixed	up to 1/16 in. (1.6 mm)	Air	GMAW, AI, FCAW	medium/heavy-duty fabrication

Ordering Information					
Tweco Style Rear Connector		Miller Style Rear Connector		Lincoln Style Rear Connector	
10 ft. (3 m), 1/16 in. (1.6 mm)	1036-1610	10 ft. (3 m), 1/16 in. (1.6 mm)	1036-1635	12 ft. (3.6 m), 1/16 in. (1.6 mm)	1036-1646
12 ft. (3.6 m), 1/16 in. (1.6 mm)	1036-1613	12 ft. (3.6 m), 1/16 in. (1.6 mm)	1036-1638	15 ft. (4.6 m), 1/16 in. (1.6 mm)	1036-1647
15 ft. (4.6 m), 1/16 in. (1.6 mm)	1036-1615	15 ft. (4.6 m), 1/16 in. (1.6 mm)	1036-1640		
Euro-Kwik Style Rear Connector		25 ft. (7.6 m), 1/16 in. (1.6 mm)	1036-1642		
15 ft. (4.6 m), 1/16 in. (1.6 mm)	1036-1623				

MIG GUNS & TIG TORCHES



## Tweco Spray Master 450 Amp MIG Gun

For heavy-duty fabrication



Standard Options Include:

- Dual Schedule On/Off Control, Locking Trigger, Rear Connector and
- Knucklehead™ Flexible Conductor Tube
- Standard Conductor Tube – (1640-1319) on all guns up to 15 ft. (4.6 m), (1630-1318) on all guns over 15 ft. (4.6 m)
- Conduit Liner – 44 Series

Specifications					
Rated Output	Gas	Wire Size	Cooled	Process	Application Usage
450 A @ 80% duty cycle	Mixed	up to 1/16 in. (1.6 mm)	Air	GMAW, AI, FCAW	heavy-duty fabrication

Ordering Information							
Tweco Style Rear Connector		Miller Style Rear Connector		Lincoln Style Rear Connector		Euro-Kwik Style Rear Connector	
10 ft. (3 m), 1/16 in. (1.6 mm)	1040-1050	10 ft. (3 m), 1/16 in. (1.6 mm)	1040-1060	10 ft. (3 m), 1/16 in. (1.6 mm)	1040-1070	10 ft. (3 m), 1/16 in. (1.6 mm)	1040-1075
12 ft. (3.6 m), 1/16 in. (1.6 mm)	1040-1051	12 ft. (3.6 m), 1/16 in. (1.6 mm)	1040-1061	15 ft. (4.6 m), 1/16 in. (1.6 mm)	1040-1072	12 ft. (3.6 m), 1/16 in. (1.6 mm)	1040-1076
15 ft. (4.6 m), 1/16 in. (1.6 mm)	1040-1052	15 ft. (4.6 m), 1/16 in. (1.6 mm)	1040-1062	25 ft. (7.6 m), 1/16 in. (1.6 mm)	1040-1071	15 ft. (4.6 m), 1/16 in. (1.6 mm)	1040-1077
20 ft. (6.1 m), 1/16 in. (1.6 mm)	1040-1059	20 ft. (6.1 m), 1/16 in. (1.6 mm)	1040-1064				
25 ft. (7.6 m), 1/16 in. (1.6 mm)	1040-1058	25 ft. (7.6 m), 1/16 in. (1.6 mm)	1040-1068				

## Tweco Spray Master Velocity2 V250 Amp MIG Gun

For light - medium-duty fabrication



Standard Options Include:

- Rear Connector and Knucklehead™ Flexible Conductor Tube
- Standard Conductor Tube – (1240-1374) on all guns up to 15 ft. (4.6 m), (1240-1373) on all guns over 15 ft. (4.6 m)
- Conduit Liner – 42 Series

Specifications					
Rated Output	Gas	Wire Size	Cooled	Process	Application Usage
250 A @ 80% duty cycle	Mixed	up to .045 in. (1.2 mm)	Air	GMAW, AI, FCAW	light/medium-duty fabrication

Ordering Information							
Tweco® Style Rear Connector		Miller Style Rear Connector		Lincoln Style Rear Connector		Euro-Kwik Style Rear Connector	
10 ft. (3 m), .045 in. (1.2 mm)	1023-1290	10 ft. (3 m), .045 in. (1.2 mm)	1023-1280	10 ft. (3 m), .045 in. (1.2 mm)	1023-1292	10 ft. (3 m), .045 in. (1.2 mm)	1023-1286
12 ft. (3.6 m), .045 in. (1.2 mm)	1023-1276	12 ft. (3.6 m), .045 in. (1.2 mm)	1023-1281	12 ft. (3.6 m), .045 in. (1.2 mm)	1023-1285	12 ft. (3.6 m), .045 in. (1.2 mm)	1023-1287
15 ft. (4.6 m), .045 in. (1.2 mm)	1023-1277	15 ft. (4.6 m), .045 in. (1.2 mm)	1023-1282	15 ft. (4.6 m), .045 in. (1.2 mm)	1023-1293	15 ft. (4.6 m), .045 in. (1.2 mm)	1023-1288
20 ft. (6.1 m), .045 in. (1.2 mm)	1023-1278	20 ft. (6.1 m), .045 in. (1.2 mm)	1023-1283	20 ft. (6.1 m), .045 in. (1.2 mm)	1023-1294	20 ft. (6.1 m), .045 in. (1.2 mm)	1023-1291
25 ft. (7.6 m), .045 in. (1.2 mm)	1023-1279	25 ft. (7.6 m), .045 in. (1.2 mm)	1023-1289	25 ft. (7.6 m), .045 in. (1.2 mm)	1023-1295	25 ft. (7.6 m), .045 in. (1.2 mm)	1023-1284

## Tweco Spray Master Velocity2 V350 Amp MIG Gun

For medium/heavy-duty fabrication



Standard Options Include:

- Dual Schedule On/Off Control, Rear Connector and Knucklehead™
- Flexible Conductor Tube
- Standard Conductor Tube – Part No. SMVCT-60 (Stock No.1240-1374) on all guns up to 15ft (4.6 m)
- Part No. SMVCT-45 (Stock No. 1240-1373) on all guns over 15 ft (4.6 m)
- Conduit Liner – 42 Series

Specifications					
Rated Output	Gas	Wire Size	Cooled	Process	Application Usage
350 A @ 80% duty cycle	Mixed	up to 1/16 in. (1.6 mm)	Air	GMAW, AI, FCAW	medium/heavy-duty fabrication

Ordering Information							
Tweco Style Rear Connector		Miller Style Rear Connector		Lincoln Style Rear Connector		Euro-Kwik Style Rear Connector	
10 ft. (3 m), 1/16 in. (1.6 mm)	1036-1750	10 ft. (3 m), 1/16 in. (1.6 mm)	1036-1751	10 ft. (3 m), 1/16 in. (1.6 mm)	1036-1785	10 ft. (3 m), 1/16 in. (1.6 mm)	1036-1784
12 ft. (3.6 m), 1/16 in. (1.6 mm)	1036-1752	12 ft. (3.6 m), 1/16 in. (1.6 mm)	1036-1754	12 ft. (3.6 m), 1/16 in. (1.6 mm)	1036-1753	12 ft. (3.6 m), 1/16 in. (1.6 mm)	1036-1779
15 ft. (4.6 m), 1/16 in. (1.6 mm)	1036-1756	15 ft. (4.6 m), 1/16 in. (1.6 mm)	1036-1765	15 ft. (4.6 m), 1/16 in. (1.6 mm)	1036-1762	15 ft. (4.6 m), 1/16 in. (1.6 mm)	1036-1770
20 ft. (6.1 m), 1/16 in. (1.6 mm)	1036-1789	20 ft. (6.1 m), 1/16 in. (1.6 mm)	1036-1780	20 ft. (6.1 m), 1/16 in. (1.6 mm)	1036-1781	20 ft. (6.1 m), 1/16 in. (1.6 mm)	1036-1782
25 ft. (7.6 m), 1/16 in. (1.6 mm)	1036-1787	25 ft. (7.6 m), 1/16 in. (1.6 mm)	1036-1775	25 ft. (7.6 m), 1/16 in. (1.6 mm)	1036-1786	25 ft. (7.6 m), 1/16 in. (1.6 mm)	1036-1790

## Tweco Spray Master Velocity2 V450 Amp MIG Gun

For heavy-duty fabrication



Standard Options Include:

- Dual Schedule On/Off Control, Locking Trigger, Rear Connector and Knucklehead Flexible Conductor Tube
- Standard Conductor Tube – (1240-1374) on all guns up to 15 ft. (4.6 m), (1240-1373) on all guns over 15 ft. (4.6 m)
- Conduit Liner – 44 Series

Specifications					
Rated Output	Gas	Wire Size	Cooled	Process	Application Usage
450 A @ 80% duty cycle	Mixed	up to 1/16 in. (1.6 mm)	Air	GMAW, AI, FCAW	heavy-duty fabrication

Ordering Information							
Tweco Style Rear Connector		Miller Style Rear Connector		Lincoln Style Rear Connector		Euro-Kwik Style Rear Connector	
10 ft. (3 m), 1/16 in. (1.6 mm)	1040-1825	10 ft. (3 m), 1/16 in. (1.6 mm)	1040-1827	10 ft. (3 m), 1/16 in. (1.6 mm)	1040-1826	10 ft. (3 m), 1/16 in. (1.6 mm)	1040-1828
12 ft. (3.6 m), 1/16 in. (1.6 mm)	1040-1829	12 ft. (3.6 m), 1/16 in. (1.6 mm)	1040-1830	12 ft. (3.6 m), 1/16 in. (1.6 mm)	1040-1866	12 ft. (3.6 m), 1/16 in. (1.6 mm)	1040-1832
15 ft. (4.6 m), 1/16 in. (1.6 mm)	1040-1833	15 ft. (4.6 m), 1/16 in. (1.6 mm)	1040-1844	15 ft. (4.6 m), 1/16 in. (1.6 mm)	1040-1839	15 ft. (4.6 m), 1/16 in. (1.6 mm)	1040-1850
20 ft. (6.1 m), 1/16 in. (1.6 mm)	1040-1854	20 ft. (6.1 m), 1/16 in. (1.6 mm)	1040-1855	20 ft. (6.1 m), 1/16 in. (1.6 mm)	1040-1869	20 ft. (6.1 m), 1/16 in. (1.6 mm)	1040-1867
25 ft. (7.6 m), 1/16 in. (1.6 mm)	1040-1859	25 ft. (7.6 m), 1/16 in. (1.6 mm)	1040-1861	25 ft. (7.6 m), 1/16 in. (1.6 mm)	1040-1860	25 ft. (7.6 m), 1/16 in. (1.6 mm)	1040-1868

MIG GUNS & TIG TORCHES

## Tweco Classic No. 1 180 Amp MIG Gun

Suitable for light-duty fabrication



Standard Options Include:

- Rear Connector
- Standard Conductor Tube – (1610-1102) on all guns up to 15 ft. (4.6 m), (1610-1101) on all guns over 15 ft. (4.6 m)
- Conduit Liner – 42 Series

Specifications					
Rated Output	Gas	Wire Size	Cooled	Process	Application Usage
180 A @ 60% duty cycle	CO <sub>2</sub>	up to .045 in. (1.2 mm)	Air	GMAW, AI	light-duty fabrication

Ordering Information			
Tweco Style Rear Connector		Miller Style Rear Connector	
10 ft. (3 m), .035 in. (0.9 mm)	1010-1111	10 ft. (3 m), .035 in. (0.9 mm)	1010-1131
12 ft. (3.6 m), .035 in. (0.9 mm)	1010-1112	12 ft. (3.6 m), .035 in. (0.9 mm)	1010-1133
15 ft. (4.6 m), .035 in. (0.9 mm)	1010-1113	15 ft. (4.6 m), .035 in. (0.9 mm)	1010-1135
20 ft. (6.1 m), .035 in. (0.9 mm)	1010-1114	Lincoln Style Rear Connector	
10 ft. (3 m), .045 in. (1.2 mm)	1010-1121	15 ft. (4.6 m), .035 in. (0.9 mm)	1010-1145
12 ft. (3.6 m), .045 in. (1.2 mm)	1010-1122	Euro-Kwik Style Rear Connector	
15 ft. (4.6 m), .045 in. (1.2 mm)	1010-1123	10 ft. (3 m), .045 in. (1.2 mm)	1010-1621
20 ft. (6.1 m), .045 in. (1.2 mm)	1010-1124	12 ft. (3.6 m), .045 in. (1.2 mm)	1010-1622

## Tweco Classic No. 2 200 Amp MIG Gun

Suitable for medium-duty fabrication



Standard Options Include:

- Rear Connector and Knucklehead™ Flexible Conductor Tube
- Standard Conductor Tube – (1620-1301) on all guns up to 15 ft. (4.6 m), (1620-1300) on all guns over 15 ft. (4.6 m)
- Conduit Liner – 42 Series

Specifications					
Rated Output	Gas	Wire Size	Cooled	Process	Application Usage
200 A @ 60% duty cycle	CO <sub>2</sub>	up to .045 in. (1.2 mm)	Air	GMAW, AI	medium-duty fabrication

Ordering Information					
Tweco Style Rear Connector		Miller Style Rear Connector		Lincoln Style Rear Connector	
10 ft. (3 m), .035 in. (0.9 mm)	1020-1111	10 ft. (3 m), .035 in. (0.9 mm)	1020-1130	10 ft. (3 m), .035 in. (0.9 mm)	1020-1140
12 ft. (3.6 m), .035 in. (0.9 mm)	1020-1112	12 ft. (3.6 m), .035 in. (0.9 mm)	1020-1132	12 ft. (3.6 m), .035 in. (0.9 mm)	1020-1142
15 ft. (4.6 m), .035 in. (0.9 mm)	1020-1113	15 ft. (4.6 m), .035 in. (0.9 mm)	1020-1134	15 ft. (4.6 m), .035 in. (0.9 mm)	1020-1144
20 ft. (6.1 m), .035 in. (0.9 mm)	1020-1114	10 ft. (3 m), .045 in. (1.2 mm)	1020-1131	Euro-Kwik Style Rear Connector	
25 ft. (7.6 m), .035 in. (0.9 mm)	1020-1115	12 ft. (3.6 m), .045 in. (1.2 mm)	1020-1133	12 ft. (3.6 m), .045 in. (1.2 mm)	1020-1622
10 ft. (3 m), .045 in. (1.2 mm)	1020-1121	15 ft. (4.6 m), .045 in. (1.2 mm)	1020-1135	15 ft. (4.6 m), .045 in. (1.2 mm)	1020-1623
12 ft. (3.6 m), .045 in. (1.2 mm)	1020-1322	15 ft. (4.6 m), .045 in. (1.2 mm)	1020-1661*		
15 ft. (4.6 m), .045 in. (1.2 mm)	1020-1123	*Knucklehead Conductor Tube (1620-1106)			
20 ft. (6.1 m), .045 in. (1.2 mm)	1020-1660				
25 ft. (7.6 m), .045 in. (1.2 mm)	1020-1125				

MIG GUNS & TIG TORCHES

## Tweco Classic No. 3 300 Amp MIG Gun

Suitable for medium/heavy-duty fabrication



Standard Options Include:

- Rear Connector
- Standard Conductor Tube – Part No. 63J-60 (Stock No. 1630-1111) on all guns up to 15 ft. (4.6 m)
- Part No. 63J-45 (Stock No. 1630-1110) on all guns over 15 ft. (4.6 m)
- Conduit Liner – 44 Series

Specifications					
Rated Output	Gas	Wire Size	Cooled	Process	Application Usage
300 A @ 60% duty cycle	CO <sub>2</sub>	up to 1/16 in. (1.6 mm)	Air	GMAW, AI	medium/heavy-duty fabrication

Ordering Information							
Tweco Style Rear Connector		Miller Style Rear Connector		Lincoln Style Rear Connector		Euro-Kwik Style Rear Connector	
10 ft. (3 m), .045 in. (1.2 mm)	1030-1101	10 ft. (3 m), .045 in. (1.2 mm)	1030-1130	10 ft. (3 m), .045 in. (1.2 mm)	1030-1140	10 ft. (3 m), .045 in. (1.2 mm)	1030-1601
12 ft. (3.6 m), .045 in. (1.2 mm)	1030-1102	12 ft. (3.6 m), .045 in. (1.2 mm)	1030-1133	12 ft. (3.6 m), .045 in. (1.2 mm)	1030-1143	12 ft. (3.6 m), .045 in. (1.2 mm)	1030-1602
15 ft. (4.6 m), .045 in. (1.2 mm)	1030-1103	15 ft. (4.6 m), .045 in. (1.2 mm)	1030-1136	15 ft. (4.6 m), .045 in. (1.2 mm)	1030-1146		
20 ft. (6.1 m), .045 in. (1.2 mm)	1030-1104	15 ft. (4.6 m), 1/16 in. (1.6 mm)	1030-1137				
25 ft. (7.6 m), .045 in. (1.2 mm)	1030-1105						
15 ft. (4.6 m), 1/16 in. (1.6 mm)	1030-1113						
25 ft. (7.6 m), 1/16 in. (1.6 mm)	1030-1115						

## Tweco Classic No. 4 400 Amp MIG Gun

Suitable for heavy-duty fabrication



Standard Options Include:

- Dual Schedule On/Off Control, Rear Connector and Knucklehead
- Flexible Conductor Tube
- Standard Conductor Tube – (1640-1106) on all guns up to 15 ft. (4.6 m), (1640-1105) on all guns over 15 ft. (4.6 m)
- Conduit Liner – 44 Series

Specifications					
Rated Output	Gas	Wire Size	Cooled	Process	Application Usage
400 A @ 60% duty cycle	CO <sub>2</sub>	up to 1/16 in. (1.6 mm)	Air	GMAW, AI, FCAW	heavy-duty fabrication

Ordering Information					
Tweco Style Rear Connector		Miller Style Rear Connector		Lincoln Style Rear Connector	
10 ft. (3 m), .035 in. (0.9 mm)	1040-1101	10 ft. (3 m), .035 in. (0.9 mm)	1040-1130	10 ft. (3 m), .035 in. (0.9 mm)	1040-1140
12 ft. (3.6 m), .035 in. (0.9 mm)	1040-1102	12 ft. (3.6 m), .035 in. (0.9 mm)	1040-1133	12 ft. (3.6 m), .035 in. (0.9 mm)	1040-1143
15 ft. (4.6 m), .035 in. (0.9 mm)	1040-1103	15 ft. (4.6 m), .035 in. (0.9 mm)	1040-1136	15 ft. (4.6 m), .035 in. (0.9 mm)	1040-1146
15 ft. (4.6 m), .035 in. (0.9 mm)	1040-1503 <sup>1</sup>	15 ft. (4.6 m), .035 in. (0.9 mm)	1040-1688 <sup>2</sup>	15 ft. (4.6 m), .035 in. (0.9 mm)	1040-1689 <sup>2</sup>
20 ft. (6.1 m), .035 in. (0.9 mm)	1040-1104	20 ft. (6.1 m), .035 in. (0.9 mm)	1040-1126	10 ft. (3 m), .045 in. (1.2 mm)	1040-1141
25 ft. (7.6 m), .035 in. (0.9 mm)	1040-1105	25 ft. (7.6 m), .035 in. (0.9 mm)	1040-1129	12 ft. (3.6 m), .045 in. (1.2 mm)	1040-1144
10 ft. (3 m), .045 in. (1.2 mm)	1040-1111	10 ft. (3 m), .045 in. (1.2 mm)	1040-1131	15 ft. (4.6 m), .045 in. (1.2 mm)	1040-1147
12 ft. (3.6 m), .045 in. (1.2 mm)	1040-1112	12 ft. (3.6 m), .045 in. (1.2 mm)	1040-1134	<b>Euro-Kwik Style Rear Connector</b>	
15 ft. (4.6 m), .045 in. (1.2 mm)	1040-1113	15 ft. (4.6 m), .045 in. (1.2 mm)	1040-1137	12 ft. (3.6 m), .035 in. (0.9 mm)	1040-1602
20 ft. (6.1 m), .045 in. (1.2 mm)	1040-1114	20 ft. (6.1 m), .045 in. (1.2 mm)	1040-1127	15 ft. (4.6 m), .035 in. (0.9 mm)	1040-1603
25 ft. (7.6 m), .045 in. (1.2 mm)	1040-1115	25 ft. (7.6 m), .045 in. (1.2 mm)	1040-1128	25 ft. (7.6 m), .035 in. (0.9 mm)	1040-1605
15 ft. (4.6 m), 1/16 in. (1.6 mm)	1040-1514 <sup>1</sup>	15 ft. (4.6 m), 5/64 in. (2.0 mm)	1040-1138	15 ft. (4.6 m), .045 in. (1.2 mm)	1040-1613
15 ft. (4.6 m), 5/64 in. (2.0 mm)	1040-1123				

1 = Dual Schedule 2 = Knucklehead Conductor Tube – 1640-1113

## Tweco Classic No. 5 500 Amp MIG Gun

Suitable for heavy-duty fabrication



Standard Options Include:

- Dual Schedule On/Off Control, Locking Trigger & Rear Connector
- Standard Conductor Tube – (1650-1111) on all guns up to 15 ft. (4.6 m), (1650-1110) on all guns over 15 ft. (4.6 m)
- Conduit Liner – 45 Series

Specifications					
Rated Output	Gas	Wire Size	Cooled	Process	Application Usage
500 A @ 60% duty cycle	CO <sub>2</sub>	up to 3/32 in. (2.4 mm)	Air	GMAW, AI, FCAW	heavy-duty fabrication

Ordering Information					
Tweco Style Rear Connector		Miller Style Rear Connector		Lincoln Style Rear Connector	
15 ft. (4.6 m), 1/16 in. (1.6 mm)	1050-1113	15 ft. (4.6 m), 1/16 in. (1.6 mm)	1050-1173	15 ft. (4.6 m), 3/32 in. (2.4 mm)	1050-1642
25 ft. (7.6 m), 1/16 in. (1.6 mm)	1050-1115	15 ft. (4.6 m), 3/32 in. (2.4 mm)	1050-1175		
10 ft. (3 m), 3/32 in. (2.4 mm)	1050-1131				
15 ft. (4.6 m), 3/32 in. (2.4 mm)	1050-1133				

## Tweco Velocity2 Classic No. 1 180 Amp MIG Gun

Suitable for light-duty fabrication



Standard Options Include:

- Rear Connector
- Standard Conductor Tube – (1610-1102) on all guns over 15 ft. (4.6 m)
- Light-duty VELOCITY2 Adapter must be ordered separately (1010-1105)
- Conduit Liner – 42 Series

Specifications					
Rated Output	Gas	Wire Size	Cooled	Process	Application Usage
180 A @ 60% duty cycle	CO <sub>2</sub>	up to .045 in. (1.2 mm)	Air	GMAW, AI	light-duty fabrication

Ordering Information					
Tweco Style Rear Connector		Miller Style Rear Connector		Euro-Kwik Style Rear Connector	
12 ft. (3.6 m), .035 in. (0.9 mm)	1010-1115	10 ft. (3 m), .035 in. (0.9 mm)	1010-1125	10 ft. (3 m), .035 in. (0.9 mm)	1010-1147
15 ft. (4.6 m), .035 in. (0.9 mm)	1010-1116	12 ft. (3.6 m), .035 in. (0.9 mm)	1010-1126	12 ft. (3.6 m), .035 in. (0.9 mm)	1010-1148
20 ft. (6.1 m), .035 in. (0.9 mm)	1010-1117	15 ft. (4.6 m), .035 in. (0.9 mm)	1010-1127	15 ft. (4.6 m), .035 in. (0.9 mm)	1010-1149
12 ft. (3.6 m), .045 in. (1.2 mm)	1010-1118	Lincoln Style Rear Connector			
15 ft. (4.6 m), .045 in. (1.2 mm)	1010-1119	15 ft. (4.6 m), .035 in. (0.9 mm)	1010-1138		
20 ft. (6.1 m), .045 in. (1.2 mm)	1010-1120				

MIG GUNS & TIG TORCHES

## Tweco Velocity2 Classic No. 2 200 Amp MIG Gun

Suitable for medium-duty fabrication



Standard Options Include:

- Rear Connector and Knucklehead™ Flexible Conductor Tube
- Standard Conductor Tube – (1620-1375) on all guns up to 15 ft. (4.6 m), (1620-1376) on all guns over 15 ft. (4.6 m)
- Conduit Liner – 42 Series

Specifications					
Rated Output	Gas	Wire Size	Cooled	Process	Application Usage
200 A @ 60% duty cycle	CO <sub>2</sub>	up to .045 in. (1.2 mm)	Air	GMAW, AI	medium-duty fabrication

Ordering Information							
Tweco Style Rear Connector		Miller Style Rear Connector		Euro-Kwik Style Rear Connector		Lincoln Style Rear Connector	
10 ft. (3 m), .035 in. (0.9 mm)	1020-1105	10 ft. (3 m), .035 in. (0.9 mm)	1020-1128	12 ft. (3.6 m), .035 in. (0.9 mm)	1020-1305	10 ft. (3 m), .035 in. (0.9 mm)	1020-1147
12 ft. (3.6 m), .035 in. (0.9 mm)	1020-1106	12 ft. (3.6 m), .035 in. (0.9 mm)	1020-1129	10 ft. (3 m), .045 in. (1.2 mm)	1020-1306	12 ft. (3.6 m), .035 in. (0.9 mm)	1020-1148
15 ft. (4.6 m), .035 in. (0.9 mm)	1020-1107	15 ft. (4.6 m), .035 in. (0.9 mm)	1020-1136	12 ft. (3.6 m), .045 in. (1.2 mm)	1020-1307	15 ft. (4.6 m), .035 in. (0.9 mm)	1020-1149
20 ft. (6.1 m), .035 in. (0.9 mm)	1020-1108	10 ft. (3 m), .045 in. (1.2 mm)	1020-1137	15 ft. (4.6 m), .045 in. (1.2 mm)	1020-1308		
25 ft. (7.6 m), .035 in. (0.9 mm)	1020-1109	12 ft. (3.6 m), .045 in. (1.2 mm)	1020-1138				
12 ft. (3.6 m), .045 in. (1.2 mm)	1020-1117	15 ft. (4.6 m), .045 in. (1.2 mm)	1020-1139				
15 ft. (4.6 m), .045 in. (1.2 mm)	1020-1118						
20 ft. (6.1 m), .045 in. (1.2 mm)	1020-1119						

## Tweco Velocity2 Classic No. 3 300 Amp MIG Gun

Suitable for medium/heavy-duty fabrication



Standard Options Include:

- Rear Connector
- Standard Conductor Tube – (1630-1229) on all guns up to 15 ft. (4.6 m), (1630-1230) on all guns over 15 ft. (4.6 m)
- Conduit Liner – 44 Series

Specifications					
Rated Output	Gas	Wire Size	Cooled	Process	Application Usage
300 A @ 60% duty cycle	CO <sub>2</sub>	up to 1/16 in. (1.6 mm)	Air	GMAW, AI	medium/heavy-duty fabrication

Ordering Information					
Tweco Style Rear Connector		Miller Style Rear Connector		Euro-Kwik Style Rear Connector	
10 ft. (3 m), .045 in. (1.2 mm)	1030-1003	10 ft. (3 m), .045 in. (1.2 mm)	1030-1013	10 ft. (3 m), .045 in. (1.2 mm)	1030-1020
12 ft. (3.6 m), .045 in. (1.2 mm)	1030-1004	12 ft. (3.6 m), .045 in. (1.2 mm)	1030-1014	12 ft. (3.6 m), .045 in. (1.2 mm)	1030-1021
15 ft. (4.6 m), .045 in. (1.2 mm)	1030-1005	15 ft. (4.6 m), .045 in. (1.2 mm)	1030-1015	15 ft. (4.6 m), .045 in. (1.2 mm)	1030-1022
20 ft. (6.1 m), .045 in. (1.2 mm)	1030-1006	15 ft. (4.6 m), 1/16 in. (1.6 mm)	1030-1016	15 ft. (4.6 m), 5/64 in. (2.0 mm)	1030-1023
25 ft. (7.6 m), .045 in. (1.2 mm)	1030-1007	Lincoln Style Rear Connector			
12 ft. (3.6 m), 1/16 in. (1.6 mm)	1030-1008	10 ft. (3 m), .045 in. (1.2 mm)	1030-1017		
15 ft. (4.6 m), 1/16 in. (1.6 mm)	1030-1009	12 ft. (3.6 m), .045 in. (1.2 mm)	1030-1018		
25 ft. (7.6 m), 1/16 in. (1.6 mm)	1030-1010	15 ft. (4.6 m), .045 in. (1.2 mm)	1030-1019		

## Tweco Velocity2 Classic No. 4 400 Amp MIG Gun

Suitable for heavy-duty fabrication



Standard Options Include:

- Dual Schedule On/Off Control, Rear Connector and Knucklehead™ Flexible Conductor Tube
- Standard Conductor Tube – (1640-1400) on all guns up to 15 ft. (4.6 m), (1640-1401) on all guns over 15 ft. (4.6 m)
- Conduit Liner – 44 Series

Specifications					
Rated Output	Gas	Wire Size	Cooled	Process	Application Usage
400 A @ 60% duty cycle	CO <sub>2</sub>	up to 1/16 in. (1.6 mm)	Air	GMAW, AI, FCAW	heavy-duty fabrication

Ordering Information							
Tweco Style Rear Connector		Miller Style Rear Connector		Euro-Kwik Style Rear Connector		Lincoln Style Rear Connector	
10 ft. (3 m), .045 in. (1.2 mm)	1040-1901	10 ft. (3 m), .045 in. (1.2 mm)	1040-1914	10 ft. (3 m), .045 in. (1.2 mm)	1040-1934	10 ft. (3 m), .045 in. (1.2 mm)	1040-1927
12 ft. (3.6 m), .045 in. (1.2 mm)	1040-1902	12 ft. (3.6 m), .045 in. (1.2 mm)	1040-1915	12 ft. (3.6 m), .045 in. (1.2 mm)	1040-1935	12 ft. (3.6 m), .045 in. (1.2 mm)	1040-1928
15 ft. (4.6 m), .045 in. (1.2 mm)	1040-1903	15 ft. (4.6 m), .045 in. (1.2 mm)	1040-1916	15 ft. (4.6 m), .045 in. (1.2 mm)	1040-1936	15 ft. (4.6 m), .045 in. (1.2 mm)	1040-1929
15 ft. (4.6 m), .045 in. (1.2 mm)	1040-1904	15 ft. (4.6 m), .045 in. (1.2 mm)	1040-1917 <sup>2</sup>	25 ft. (7.6 m), .045 in. (1.2 mm)	1040-1937	15 ft. (4.6 m), .045 in. (1.2 mm)	1040-1930 <sup>2</sup>
15 ft. (4.6 m), .045 in. (1.2 mm)	1040-1905 <sup>2</sup>	20 ft. (6.1 m), .045 in. (1.2 mm)	1040-1918	12 ft. (3.6 m), 1/16 in. (1.6 mm)	1040-1938	12 ft. (3.6 m), 1/16 in. (1.6 mm)	1040-1931
20 ft. (6.1 m), .045 in. (1.2 mm)	1040-1906	25 ft. (7.6 m), .045 in. (1.2 mm)	1040-1919	15 ft. (4.6 m), 1/16 in. (1.6 mm)	1040-1939	15 ft. (4.6 m), 1/16 in. (1.6 mm)	1040-1932
25 ft. (7.6 m), .045 in. (1.2 mm)	1040-1907	10 ft. (3 m), 1/16 in. (1.6 mm)	1040-1920	15 ft. (4.6 m), 5/64 in. (2.0 mm)	1040-1940		
10 ft. (3 m), 1/16 in. (1.6 mm)	1040-1908	12 ft. (3.6 m), 1/16 in. (1.6 mm)	1040-1921				
12 ft. (3.6 m), 1/16 in. (1.6 mm)	1040-1909	15 ft. (4.6 m), 1/16 in. (1.6 mm)	1040-1922				
15 ft. (4.6 m), 1/16 in. (1.6 mm)	1040-1900	20 ft. (6.1 m), 1/16 in. (1.6 mm)	1040-1923				
20 ft. (6.1 m), 1/16 in. (1.6 mm)	1040-1911	25 ft. (7.6 m), 1/16 in. (1.6 mm)	1040-1924				
15 ft. (4.6 m), 5/64 in. (2.0 mm)	1040-1912	15 ft. (4.6 m), 5/64 in. (2.0 mm)	1040-1925				

<sup>1</sup> = Dual Schedule  
<sup>2</sup> = Knucklehead Conductor Tube – 1640-1113

## Tweco Velocity2 Classic No. 5 500 Amp MIG Gun

Suitable for heavy-duty fabrication



Standard Options Include:

- Dual Schedule On/Off Control, Locking Trigger & Rear Connector
- Standard Conductor Tube – (1660-1251) on all guns up to 15 ft. (4.6 m), (1660-1252) on all guns over 15 ft. (4.6 m)
- Conduit Liner – 45 Series

Specifications					
Rated Output	Gas	Wire Size	Cooled	Process	Application Usage
500 A @ 60% duty cycle	CO <sub>2</sub>	up to 3/32 in. (2.4 mm)	Air	GMAW, AI, FCAW	heavy-duty fabrication

Ordering Information			
Tweco Style Rear Connector		Miller Style Rear Connector	
12 ft. (3.6 m), .045 in. (1.2 mm)	1050-1084	15 ft. (4.6 m), 1/16 in. (1.6 mm)	1050-1091
15 ft. (4.6 m), .045 in. (1.2 mm)	1050-1085	15 ft. (4.6 m), 3/32 in. (2.4 mm)	1050-1092
15 ft. (4.6 m), 1/16 in. (1.6 mm)	1050-1086	Lincoln Style Rear Connector	
25 ft. (4.6 m), 1/16 in. (1.6 mm)	1050-1087	15 ft. (4.6 m), 1/16 in. (1.6 mm)	1050-1094
10 ft. (3 m), 3/32 in. (2.4 mm)	1050-1088	Euro-Kwik Style Rear Connector	
15 ft. (4.6 m), 3/32 in. (2.4 mm)	1050-1089	15 ft. (4.6 m), 1/16 in. (1.6 mm)	1050-1096

MIG GUNS & TIG TORCHES

## Tweco Fusion 180 Amp MIG Gun

Suitable for light-duty fabrication



Standard Options Include:

- High Performance Velocity Consumables and Rear Connector
- Conduit Liner – WS42 Series

Specifications					
Rated Output	Gas	Wire Size	Cooled	Process	Application Usage
180 A @ 40% duty cycle	CO <sub>2</sub>	up to .035 in. (0.9 mm)	Air	GMAW, AI	light-duty fabrication
Ordering Information					
Tweco Style (4 Pin) Rear Connector			Miller Style Rear Connector		
12 ft. (3.6 m), .035 in. (0.9 mm)	1017-1331		12 ft. (3.6 m), .035 in. (0.9 mm)	1017-1330	
Tweco Style (8 Pin) Rear Connector			Euro-Kwik Style Rear Connector		
10 ft. (3 m), .035 in. (0.9 mm)	1017-1338		10 ft. (3 m), .035 in. (0.9 mm)	1017-1335	
12 ft. (3.6 m), .035 in. (0.9 mm)	1017-1332		Lincoln Style Rear Connector		
			12 ft. (3.6 m), .035 in. (0.9 mm)	1017-1329	

*Note: Gun length is measured from the front case to the rear case +/-3".*

## Tweco PulseMaster 450 Amp MIG Gun

Suitable for heavy-duty fabrication



- Smart capability
- Heavy-duty design
- Ergonomic impact resistant handle
- Multiple-position conductor tube

Specifications					
Rated Output	Gas	Wire Size	Cooled	Process	Application Usage
450 A @ 60% duty cycle	Mixed	up to .045 in. (1.2 mm)	Air	GMAW, AI	heavy-duty fabrication
Ordering Information					
Tweco Style Rear Connector - Smart		Tweco Style Rear Connector - Standard		Euro-Kwik Style Rear Connector - Smart	
12 ft. (3.6 m), .045 in. (1.2 mm)	1041-1510	12 ft. (3.6 m), .045 in. (1.2 mm)	1041-1500	12 ft. (3.6 m), .045 in. (1.2 mm)	1041-1515
15 ft. (4.6 m), .045 in. (1.2 mm)	1041-1511	15 ft. (4.6 m), .045 in. (1.2 mm)	1041-1501	15 ft. (4.6 m), .045 in. (1.2 mm)	1041-1516

*PulseMaster Smart MIG Guns are used only with Tweco PowerMaster SP machines and are available with "Smart" Capability. PulseMaster MIG Guns are Standard without "Smart" Capability.*

MIG GUNS & TIG TORCHES



## Tweco Compact Eliminator 250 Amp MIG Gun

Suitable for light/medium-duty fabrication



Standard Options Include:

- Rear Connector
- Standard Conductor Tube – (1630-1136)
- Conduit Liner – 44 Series

Specifications					
Rated Output	Gas	Wire Size	Cooled	Process	Application Usage
250 A @ 60% duty cycle	CO <sub>2</sub>	up to .045 in. (1.2 mm)	Air	GMAW, AI, FCAW	light/medium-duty fabrication

Ordering Information					
Tweco Style Rear Connector			Miller Style Rear Connector		
12 ft. (3.6 m), .045 in. (1.2 mm)		1028-1108	12 ft. (3.6 m), .045 in. (1.2 mm)		1028-1158
15 ft. (4.6 m), .045 in. (1.2 mm)		1028-1112	15 ft. (4.6 m), .045 in. (1.2 mm)		1028-1162
Lincoln Style Rear Connector			25 ft. (7.6 m), .045 in. (1.2 mm)		1028-1170
15 ft. (4.6 m), .045 in. (1.2 mm)		1028-1186			

## Tweco Compact Eliminator 450 Amp MIG Gun

Suitable for light/medium-duty fabrication



Standard Options Include:

- Rear Connector
- Standard Conductor Tube – (1640-1137)
- Conduit Liner – 44 Series

Specifications					
Rated Output	Gas	Wire Size	Cooled	Process	Application Usage
450 A @ 60% duty cycle	CO <sub>2</sub>	up to 1/16 in. (1.6 mm)	Air	GMAW, AI, FCAW	heavy-duty fabrication

Ordering Information					
Tweco® Style Rear Connector		Miller Style Rear Connector		Lincoln Style Rear Connector	
15 ft. (4.6 m), .045 in. (1.2 mm)	1048-1210	10 ft. (3 m), .045 in. (1.2 mm)	1048-1250	15 ft. (4.6 m), .045 in. (1.2 mm)	1048-1285
15 ft. (4.6 m), 1/16 in. (1.6 mm)	1048-1211	12 ft. (3.6 m), .045 in. (1.2 mm)	1048-1255	15 ft. (4.6 m), 1/16 in. (1.6 mm)	1048-1286
20 ft. (6.1 m), 1/16 in. (1.6 mm)	1048-1216	15 ft. (4.6 m), .045 in. (1.2 mm)	1048-1260	Euro-Kwik Style Rear Connector	
25 ft. (7.6 m), 1/16 in. (1.6 mm)	1048-1221	15 ft. (4.6 m), 1/16 in. (1.6 mm)	1048-1261	12 ft. (3.6 m), .045 in. (1.2 mm)	1048-1230
		25 ft. (7.6 m), 1/16 in. (1.6 mm)	1048-1271	15 ft. (4.6 m), .045 in. (1.2 mm)	1048-1235

MIG GUNS & TIG TORCHES

## Tweco Velocity2 Mini-MIG 160 Amp MIG Gun

Suitable for light-duty fabrication

Standard Options Include:

- Rear Connector and Knucklehead™ Flexible Conductor Tube
- Standard Conductor Tube (1600-1106) on all guns
- Conduit Liner - 23 & 35 Series



Specifications					
Rated Output	Gas	Wire Size	Cooled	Process	Application Usage
160 A @ 60% duty cycle	CO <sub>2</sub>	up to .035 in. (0.9 mm)	Air	GMAW, AI, FCAW	light-duty fabrication

Ordering Information			
Tweco Style Rear Connector 6		Miller Style Rear Connector	
10 ft. (3.0 m), .035 in. (0.9 mm)	1000-1800	10 ft. (3.0 m), .035 in. (0.9 mm)	1000-1804
12 ft. (3.6 m), .035 in. (0.9 mm)	1000-1801	10 ft. (3.0 m), .035 in. (0.9 mm)	1000-1805
15 ft. (4.6 m), .035 in. (0.9 mm)	1000-1802	10 ft. (3.0 m), .035 in. (0.9 mm)	1000-1806
Euro-Kwik Style Rear Connector		12 ft. (3.6 m), .035 in. (0.9 mm)	1000-1807
10 ft. (3.0 m), .035 in. (0.9 mm)	1000-1816	15 ft. (4.6 m), .035 in. (0.9 mm)	1000-1808
10 ft. (3.0 m), .035 in. (0.9 mm)	1000-1817	Lincoln Style Rear Connector	
12 ft. (3.6 m), .035 in. (0.9 mm)	1000-1818	10 ft. (3.0 m), .035 in. (0.9 mm)	1000-1810
15 ft. (4.6 m), .035 in. (0.9 mm)	1000-1819	10 ft. (3.0 m), .035 in. (0.9 mm)	1000-1811
		12 ft. (3.6 m), .035 in. (0.9 mm)	1000-1812
		15 ft. (4.6 m), .035 in. (0.9 mm)	1000-1813
		15 ft. (4.6 m), .035 in. (0.9 mm)	1000-1814

## Tweco Mini-MIG 160 Amp MIG Gun

Suitable for light-duty fabrication

Standard Options Include:

- Rear Connector and Knucklehead™ Flexible Conductor Tube
- Standard Conductor Tube – (1600-1102) on all guns
- Conduit Liner – 23 & 35 Series



Specifications					
Rated Output	Gas	Wire Size	Cooled	Process	Application Usage
160 A @ 60% duty cycle	CO <sub>2</sub>	up to .035 in. (0.9 mm)	Air	GMAW, AI, FCAW	light-duty fabrication

Ordering Information			
Tweco Style Rear Connector		Lincoln Style Rear Connector	
10 ft. (3 m), .035 in. (0.9 mm)	1000-1131	10 ft. (3 m), .035 in. (0.9 mm)	1000-1231
12 ft. (3.6 m), .035 in. (0.9 mm)	1000-1132	12 ft. (3.6 m), .035 in. (0.9 mm)	1000-1231
15 ft. (4.6 m), .035 in. (0.9 mm)	1000-1133	15 ft. (4.6 m), .035 in. (0.9 mm)	1000-1232
Miller Style Rear Connector		15 ft. (4.6 m), .035 in. (0.9 mm)	1000-1236 <sup>1</sup>
10 ft. (3 m), .035 in. (0.9 mm)	1000-1210	Euro-Kwik Style Rear Connector	
10 ft. (3 m), .035 in. (0.9 mm)	1000-1211	10 ft. (3 m), .035 in. (0.9 mm)	1000-1621
12 ft. (3.6 m), .035 in. (0.9 mm)	1000-1213	10 ft. (3 m), .035 in. (0.9 mm)	1000-1631
15 ft. (4.6 m), .035 in. (0.9 mm)	1000-1215	12 ft. (3.6 m), .035 in. (0.9 mm)	1000-1632
		15 ft. (4.6 m), .035 in. (0.9 mm)	1000-1633

<sup>1</sup>Fits Lincoln Power MIG 140/180 machines.

MIG GUNS & TIG TORCHES

## Tweco Supra XT SEHD 400 Amp MIG Gun

Suitable for medium/heavy-duty fabrication



Standard Options Include:

- Rear Connector
- Available with Heavy Duty Front End Consumables
- Standard Conductor Tube – (1640-1347) on all guns up to 15 ft. (4.6 m)
- Conduit Liner – 44 Series

Specifications					
Rated Output	Gas	Wire Size	Cooled	Process	Application Usage
400 A @ 60% duty cycle	CO <sub>2</sub>	up to 1/16 in. (1.6 mm)	Air	GMAW, AI, FCAW	medium/heavy-duty fabrication

Ordering Information					
Tweco Style Rear Connector			Euro-Kwik Style Rear Connector		
15 ft. (4.6 m), 1/16 in. (1.6 mm)		1040-1332	15 ft. (4.6 m), 1/16 in. (1.6 mm)		1040-1442
Miller Style Rear Connector			Lincoln Style Rear Connector		
15 ft. (4.6 m), 1/16 in. (1.6 mm)		1040-1342	15 ft. (4.6 m), 1/16 in. (1.6 mm)		1040-1432

## Tweco Velocity2 Supra XT VSEHD 400 Amp MIG Gun

Suitable for medium/heavy-duty fabrication



Standard Options Include:

- Rear connector
- Heavy-duty VELOCITY2 front end consumables
- Standard conductor tubes (1640-1160) on all guns up to 15 ft. (4.6 m), (1640-1161) on all guns over 15 ft. (4.6 m)
- "LM" long reach conductor tubes are available

Specifications					
Rated Output	Gas	Wire Size	Cooled	Process	Application Usage
400 A @ 60% duty cycle	CO <sub>2</sub>	up to .035 in. (0.9 mm)	Air	GMAW, AI, FCAW	medium/heavy-duty fabrication

Ordering Information					
Tweco Style Rear Connector			Lincoln Style Rear Connector		
15 ft. (4.6 m), 1/16 in. (1.6 mm)		1040-1880	15 ft. (4.6 m), 1/16 in. (1.6 mm)		1040-1888
25 ft. (7.6 m), 1/16 in. (1.6 mm)		1040-1881	25 ft. (7.6 m), 1/16 in. (1.6 mm)		1040-1889
15 ft. (4.6 m), 1/16 in. (1.6 mm)		1040-1882*	15 ft. (4.6 m), 1/16 in. (1.6 mm)		1040-1890*
25 ft. (7.6 m), 1/16 in. (1.6 mm)		1040-1883*	25 ft. (7.6 m), 1/16 in. (1.6 mm)		1040-1891*
Euro-Kwik Style Rear Connector			Miller Style Rear Connector		
15 ft. (4.6 m), 1/16 in. (1.6 mm)		1040-1892	15 ft. (4.6 m), 1/16 in. (1.6 mm)		1040-1884
25 ft. (7.6 m), 1/16 in. (1.6 mm)		1040-1893	25 ft. (7.6 m), 1/16 in. (1.6 mm)		1040-1885
15 ft. (4.6 m), 1/16 in. (1.6 mm)		1040-1894*	15 ft. (4.6 m), 1/16 in. (1.6 mm)		1040-1886*
25 ft. (7.6 m), 1/16 in. (1.6 mm)		1040-1895*	25 ft. (7.6 m), 1/16 in. (1.6 mm)		1040-1887*

\*LM - long reach conductor tube.

## Tweco Smoke Master 250 Amp Fume Extraction Air-Cooled MIG Gun

Suitable for light/medium-duty fabrication



Standard Options Include:

- Rear Connector
- Standard Conductor Tube – (2020-2006) on all guns up to 15 ft. (4.6 m)
- Conduit Liner – 42 Series

Specifications					
Rated Output	Gas	Wire Size	Cooled	Process	Application Usage
250 A @ 60% duty cycle	CO <sub>2</sub>	up to .045 in. (1.2 mm)	Air	GMAW, AI, FCAW	medium-duty fabrication
Ordering Information					
Tweco Style Rear Connector			Miller Style Rear Connector		
15 ft. (4.6 m), .045 in. (1.2 mm)		1026-1102	15 ft. (4.6 m), .045 in. (1.2 mm)		1026-1107
Euro-Kwik Style Rear Connector					
15 ft. (4.6 m), .045 in. (1.2 mm)		1026-1127			

## Tweco Smoke Master 450 Amp Fume Extraction Air-Cooled MIG Gun

Suitable for medium/heavy-duty fabrication



Standard Options Include:

- Rear Connector and Knucklehead™ Flexible Conductor Tube
- Standard Conductor Tube – (1600-1102) on all guns
- Conduit Liner – 23 & 35 Series

Specifications					
Rated Output	Gas	Wire Size	Cooled	Process	Application Usage
450 A @ 60% duty cycle	CO <sub>2</sub>	up to 1/16 in. (1.6 mm)	Air	GMAW, AI, FCAW	medium/heavy-duty fabrication
Ordering Information					
Tweco Style Rear Connector		Miller Style Rear Connector		Lincoln Style Rear Connector	
15 ft. (4.6 m), 1/16 in. (1.6 mm)	1046-1108	12 ft. (3.6 m), 1/16 in. (1.6 mm)	1046-1125	15 ft. (4.6 m), 1/16 in. (1.6 mm)	1046-1138
		15 ft. (4.6 m), 1/16 in. (1.6 mm)	1046-1128		

MIG GUNS & TIG TORCHES

## Tweco PullMaster 300 Amp MIG Gun

Suitable for light to heavy-duty fabrication

Standard Options Include:

- Rear Connector
- Standard without “Smart” capability
- Available with Smart Capability
- Standard Conductor Tube – (1642-1140)
- Available with Optional 30° Rigid or Knucklehead
- Flexible Conductor Tube

Tweco PullMaster Standard MIG Gun

Tweco PullMaster Smart MIG Gun with digital display



Specifications					
Rated Output	Gas	Wire Size	Cooled	Process	Application Usage
200 A @ 60% duty cycle	Mixed	up to .045 in. (1.2 mm)	Air	GMAW, AI	light - heavy-duty fabrication

Ordering Information			
Tweco Style Rear Connector - Standard		Tweco Style Rear Connector - Smart	
33 ft. (10.1 m), .045 in. (1.2 mm)	1027-1401	33 ft. (10.1 m), .045 in. (1.2 mm)	1027-1407

*PullMaster Smart MIG Guns are used only with Tweco PowerMaster SP machines and are available with “Smart” Capability.*

## Tweco Flux-Cored SEFC 450 Amp MIG Gun

Suitable for heavy-duty fabrication

Standard Options Include:

- Rear Connector
- Standard Conductor Tube – (1641-1127) on all guns up to 15 ft. (4.6 m)
- Conduit Liner – 44 Series



Specifications					
Rated Output	Gas	Wire Size	Cooled	Process	Application Usage
450 A @ 60% duty cycle	CO <sub>2</sub>	up to 1/8 in. (3.2 mm)	Air	GMAW, FCAW	heavy-duty fabrication

Ordering Information					
Tweco Style Rear Connector		Miller Style Rear Connector		Lincoln Style Rear Connector	
15 ft. (4.6 m), 3/32 in. (2.5 mm)	1041-1120	15 ft. (4.6 m), 3/32 in. (2.5 mm)	1041-1139	15 ft. (4.6 m), 3/32 in. (2.5 mm)	1041-1113

MIG GUNS & TIG TORCHES

# TWECO® VELOCITY2™ – LESS DOWNTIME, MORE WELD TIME.

Introducing VELOCITY2, the longest-lasting MIG consumables on the market. These groundbreaking consumables deliver superior welding performance and a better operator experience.



## SPEED AND EFFICIENCY.

The threadless contact tip design eliminates problems with threads, so tip changes take seconds and require no tools.



Updated VELOCITY2 consumables feature a simpler, more robust design. The large copper-to-copper contact surface promotes superior thermal and electrical efficiency. As a result, consumables stay cooler, last longer and produce a smoother arc with reduced spatter. A silicone sleeve over the copper conductor tube minimizes radiant heat and improves impact resistance.

## INNOVATION.

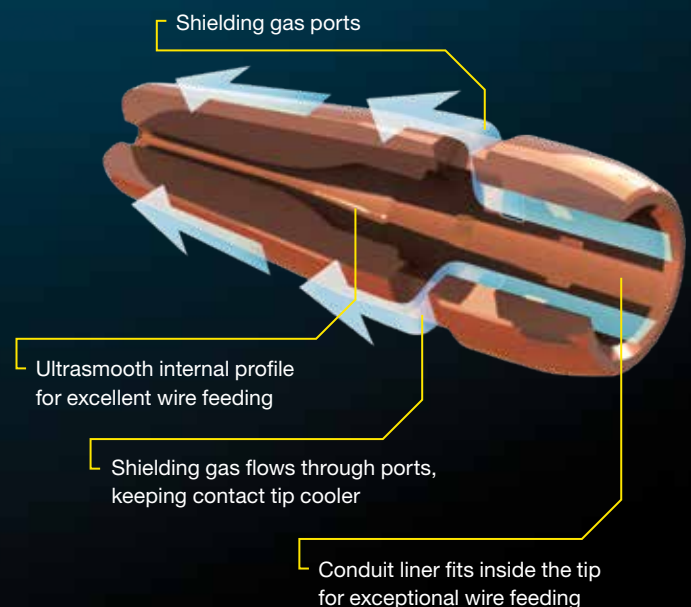

Shielding gas ports

Ultrasmooth internal profile for excellent wire feeding

Shielding gas flows through ports, keeping contact tip cooler

Conduit liner fits inside the tip for exceptional wire feeding

**VELOCITY2™**

Learn more at [esab.com/velocity2](https://esab.com/velocity2)

## ESAB PPG 26 KD Air-Cooled Electric Push-Pull MIG Gun

Suitable for light/medium-duty fabrication



- Air-cooled pistol grip guns with straight and curved 45 degrees swan necks
- Allows 360 degrees rotation of the curved swan neck to fit various welding positions
- Couples with ESAB feeding mechanisms to perform a high performance push-pull feeding system
- Ideal for feeding aluminum and other small diameter wires long distances up to 25 ft. from the main wire feed unit
- Wire feed speed control by potentiometer located in the gun handle

Specifications						
Rated Output		Gas	Wire Size	Cooled	Process	Application Usage
CO <sub>2</sub>	290 A @ 60% duty cycle	CO <sub>2</sub> , Mixed	up to .045 in. (1.2 mm)	Air	GMAW, AI	light/medium-duty fabrication
Mixed	260 A @ 60% duty cycle					
Ordering Information						
PPG 26 KD Push-Pull Welding Gun, 25 ft. (7.6 m), 180 deg.				0558101935		
PPG 26 KD Push-Pull Welding Gun, 25 ft. (7.6 m), 45 deg.				0558101936		
PPG 26 KD Push-Pull Welding Gun, 15 ft. (4.6 m), 180 deg.				0558101937		
PPG 26 KD Push-Pull Welding Gun, 15 ft. (4.6 m), 45 deg.				0558101938		

## ESAB PPW 401D Water-Cooled Electric Push-Pull MIG Gun

Suitable for medium/heavy-duty fabrication



- Water-cooled pistol grip guns with straight and curved 45 degrees swan necks
- Allows 360 degrees rotation of the curved swan neck to fit various welding positions
- Couples with ESAB feeding mechanisms to perform a high performance push-pull feeding system
- Ideal for feeding aluminium and other small diameter wires long distances up to 25 ft. (7.6 m) from the main wire feed unit
- Wire feed speed control by potentiometer located in the gun handle

Specifications						
Rated Output		Gas	Wire Size	Cooled	Process	Application Usage
CO <sub>2</sub>	420 A @ 60% duty cycle	CO <sub>2</sub> , Mixed	up to 1/16 in. (1.6 mm)	Water	GMAW, AI	medium/heavy-duty fabrication
Mixed	380 A @ 60% duty cycle					
Ordering Information						
PPW 401D Push-Pull Welding Gun, 25 ft. (7.6 m), 180 deg.				0558101892		
PPW 401D Push-Pull Welding Gun, 25 ft. (7.6 m), 45 deg.				0558101893		
PPW 401D Push-Pull Welding Gun, 15 ft. (4.6 m), 180 deg.				0558101920		
PPW 401D Push-Pull Welding Gun, 15 ft. (4.6 m), 45 deg.				0558101921		

## Tweco PulseMaster 400 Amp Water-Cooled MIG Gun

Suitable for heavy-duty fabrication



Standard Options Include:

- Rear Connector
- Standard without “Smart” Capability, but available with “Smart” Capability
- Standard Conductor Tube – (1642-1130)
- Conduit Liner – 44 Series

Specifications					
Rated Output	Gas	Wire Size	Cooled	Process	Application Usage
400 A @ 100% duty cycle	Mixed	up to .045 in. (1.2 mm)	Water	GMAW, AI	heavy-duty fabrication
Ordering Information					
Tweco Style Rear Connector - Smart			Euro-Kwik Style Rear Connector - Smart		
12 ft. (3.6 m), .045 in. (1.2 mm)		1042-1510	12 ft. (3.6 m), .045 in. (1.2 mm)		1042-1515
15 ft. (4.6 m), .045 in. (1.2 mm)		1042-1511	Euro-Kwik Style Rear Connector - Standard		
Tweco Style Rear Connector - Standard			12 ft. (3.6 m), .045 in. (1.2 mm)		1042-1505
12 ft. (3.6 m), .045 in. (1.2 mm)		1042-1500			

PulseMaster Smart MIG Guns are used only with Tweco PowerMaster SP machines and are available with “Smart” Capability. PulseMaster MIG Guns are Standard without “Smart” Capability.

## Tweco PulseMaster 500 Amp Water-Cooled MIG Gun

Suitable for heavy-duty fabrication



Standard Options Include:

- Rear Connector
- Standard without “Smart” Capability
- Available with “Smart” Capability
- Standard Conductor Tube – (1642-1140)
- Conduit Liner – 44 Series

Specifications					
Rated Output	Gas	Wire Size	Cooled	Process	Application Usage
500 A @ 100% duty cycle	Mixed	up to .045 in. (1.2 mm)	Water	GMAW, AI	heavy-duty fabrication
Ordering Information					
Tweco Style Rear Connector - Smart		Euro-Kwik Style Rear Connector - Smart		Euro-Kwik Style Rear Connector - Standard	
12 ft. (3.6 m), .045 in. (1.2 mm)	1042-1535	12 ft. (3.6 m), .045 in. (1.2 mm)	1042-1540	15 ft. (4.6 m), .045 in. (1.2 mm)	1042-1531

PulseMaster Smart MIG Guns are used only with Tweco PowerMaster SP machines and are available with “Smart” Capability. PulseMaster MIG Guns are Standard without “Smart” Capability.



## Tweco Standard 600 Amp Water-Cooled MIG Gun

Suitable for heavy-duty fabrication



Standard Options Include:

- Rear Connector
- Standard Conductor Tube – (1664-1106)
- Conduit Liner – 45 Series
- Ergonomic Handle
- Low Bench Weight for easy to handle gun
- Cooling benefits
- Large water lines, threaded water line connections and high water flow rates

Specifications					
Rated Output	Gas	Wire Size	Cooled	Process	Application Usage
600 A @ 100% duty cycle	CO <sub>2</sub>	up to 7/64 in. (2.8 mm)	Water	GMAW, AI	heavy-duty fabrication

Ordering Information			
Tweco Style Rear Connector - Smart			
10 ft. (3 m), 1/16 in. (1.6 mm)	1064-1114	15 ft. (4.6 m), 1/16 in. (1.6 mm)	1064-1116
15 ft. (4.6 m), .045 in. (1.2 mm)	1064-1106		

Adapter kits are available to fit Tweco rear connection to most wire feeders.

## ESAB ST Water-Cooled MIG Guns

Suitable for medium/heavy-duty fabrication



- Rated at 600A with any shielding gas
- Handles flux cored wires to 7/64 in. (2.8 mm)
- ST-21M has an in-line body style designed for mechanized applications



Specifications	ST-16	ST-21	ST-21M
Gun capacity	600A @ 100% duty cycle	600A @ 100% duty cycle	600A @ 100% duty cycle
Dimensions, LxH	13-3/4 x 4-1/4 in. (350 x 110 mm)	12-1/2x7-1/16 (315x180)	10.25 (260) (length only)
Handle diameter)	1-3/8 in. (35 mm)	1-3/8 in. (35 mm)	1-3/8 (35)
Gun angle	55°	180°	180°
Weight, (less service lines)	28 oz. (794 g)	38 oz. (1077 g)	28 (794)
Cooling requirements	1.6 qt/min (1.5 L/min) minimum	1.6 qt/min (1.5 L/min) minimum	1.6 qt/min (1.5 L/min) minimum
Wires accommodated:			
Hard	.030-3/32 in. (0.8-2.4 mm)	.030-3/32 in. (0.8-2.4 mm)	.030-3/32 in. (0.8-2.4 mm)
Soft	.035-3/32 in. (0.9-2.4 mm)	.035-3/32 in. (0.9-2.4 mm)	.035-3/32 in. (0.9-2.4 mm)
Cored	.030-7/64 in. (0.8-2.8 mm)	.030-7/64 in. (0.8-2.8 mm)	.030-7/64 in. (0.8-2.8 mm)

Ordering Information	
ST-16, 10 ft. (3 m)	997498
ST-21, 12 ft. (3.6 m)	995950
ST-21M, 2 ft. (0.6 m)	690509

Does not include liner/conduits, contact tips/tubes or nozzles.

MIG GUNS & TIG TORCHES

## Tweco Spool Guns

Suitable for light to medium-duty fabrication



Standard Options Include:

- 8-pin Amphenol Style Connector
- Standard Straight (180°) Conductor Tube
- Holds standard 4" (102 mm) diameter spools
- Optional 30° Rigid Conductor Tube or Knucklehead Flexible Conductor Tube
- Use for aluminum, stainless steel and mild steel applications
- Comfortable pistol-grip handle design
- Three-layer conductor tube construction
- 3-turn potentiometer

### Specifications - Light-Duty 160 Amp

Rated Output	Gas	Wire Size	Cooled	Process	Application Usage
180 A @ 20% duty cycle	Mixed	up to .035 in. (0.9 mm)	Air	GMAW, AI	light-duty fabrication

### Specifications - Medium-Duty 200 Amp

Rated Output	Gas	Wire Size	Cooled	Process	Application Usage
200 A @ 60% duty cycle	Mixed	up to .045 in. (1.2 mm)	Air	GMAW, AI	medium-duty fabrication

### Ordering Information

#### Tweco Style Rear Connector

160 Amp - 12 ft. (3.6 m), .035 in. (0.9 mm) (Thermal Arc)	1027-1390	160 Amp - 12 ft. (3.6 m), .035 in. (0.9 mm) (Rebel)	1027-1397
200 Amp - 12 ft. (3.6 m), .045 in. (1.2 mm)	1027-1398	200 Amp - 25 ft. (7.6 m), .045 in. (1.2 mm) (standard offering with 4-pin)	1027-1392
200 Amp - 25 ft. (7.6 m), .045 in. (1.2 mm) (Rebel)	1027-1399	200 Amp - 25 ft. (7.6 m), .045 in. (1.2 mm) (Thermal Arc)	1027-1391

## ESAB ST-23A Spool Gun

Suitable for medium/heavy-duty fabrication



- Service lines enter the rear of gun instead of handle for improved balance and accessibility
- Inching push button mounted on bottom of handle
- 30 ft. (9 m) service lines
- Uses durable contact tips and nozzles
- Powerful gear motor in handle pulls welding wire from 4 in. (101.5 mm) diameter spool in the molded gun case
- Partial depression of the torch trigger controls gas pre- and post-flow operations - full depression provides wire feeding as well as gas flow
- Wire feed control mounted on gun provides precise adjustment of wire feed rate at torch

### Specifications

Rated Output	Gas	Wire Size	Cooled	Process	Application Usage
250 A @ 100% duty cycle	Mixed	up to 1/16 in. (1.6 mm)	Air	GMAW, AI	medium/heavy-duty fabrication

### Ordering Information

ST-23A Spool Gun	19164
------------------	-------

Includes: one 3/64 in. (1.2 mm) contact tip, drive roll, liner, control cable, gas hose and #10 nozzle and 30 ft. (9 m) service lines.

# TXH GTAW Torches

TXH-121, 151, 201, 251, 401



- TXH torches are designed to provide the utmost in convenience, versatility, and ergonomics to the welder
- Choose between air-cooled and water-cooled versions, with or without gas valve, and with or without a flexible neck to suit specific applications
- The torch heads are manufactured with high temperature resistant silicone rubber insulation
- All copper components ensure cooler running temperatures and maximum current capacity
- Integrated dual soft grips ensure the handle remains in place with minimal grip pressure
- Positioning of the torch is made easier by the combination of knuckle joints and a flexible leather section covering the first 31.5 in. (800 mm) of the torch immediately behind the handle

## Specifications

	TXH-121	TXH-151	TXH-201	TXH-251w	TXH-401w	TXH-401w HD
Permitted load at: 35% duty cycle 60% duty cycle 100% duty cycle	- 120A 100A	150A 120A 100A	200A 150A 140A	- 250A 200A	400A 350A 300A	430A 400A -
◀ Ø in. (mm)	.040-1/8 in. (1.0-3.2 mm)	.040-1/8 in. (1.0-3.2 mm)	.040-5/32 in. (1.0-4.0 mm)	.040-1/8 in. (1.0-3.2 mm)	.040-3/16 in. (1.0-4.8 mm)	.040-3/16 in. (1.0-4.8 mm)

## Ordering Information

Air-Cooled Torches – OKC25 Connector [1 in. (25 mm)]		Air-Cooled Torches – OKC50 Connector [2 in. (50 mm)]	
TXH-121, 13 ft. (4 m) <sup>1</sup>	0700300522	TXH-121, 13 ft. (4 m)	0700300524
TXH-121, 13 ft. (4 m)	0700300532	TXH-121, 26 ft. (8 m)	0700300529
TXH-121, 26 ft. (8 m) <sup>1</sup>	0700300527	TXH-121F, 13 ft. (4 m)	0700300526
TXH-121, 26 ft. (8 m)	0700300534	TXH-121F, 26 ft. (8 m)	0700300531
TXH-121V, 13 ft. (4 m)	0700300523	TXH-151, 13 ft. (4 m)	0700300538
TXH-121V, 26 ft. (8 m)	0700300528	TXH-151, 26 ft. (8 m)	0700300544
TXH-121F, 13 ft. (4 m)	0700300525	TXH-151V, 13 ft. (4 m)	0700300539
TXH-121F, 26 ft. (8 m)	0700300530	TXH-151V, 26 ft. (8 m)	0700300545
TXH-151, 13 ft. (4 m) <sup>1</sup>	0700300538	TXH-151F, 13 ft. (4 m)	0700300541
TXH-151, 13 ft. (4 m)	0700300548	TXH-151F, 26 ft. (8 m)	0700300547
TXH-151, 26 ft. (8 m)	0700300550	TXH-201, 13 ft. (4 m)	0700300552
TXH-151, 26 ft. (8 m) <sup>1</sup>	0700300542	TXH-201, 26 ft. (8 m)	0700300555
TXH-151V, 13 ft. (4 m)	0700300537	TXH-201V, 13 ft. (4 m)	0700300553
TXH-151V, 26 ft. (8 m)	0700300543	TXH-201V, 26 ft. (8 m)	0700300556
TXH-151F, 13 ft. (4 m)	0700300540	TXH-201F, 13 ft. (4 m)	0700300554
TXH-151F, 26 ft. (8 m)	0700300546	TXH-201F, 26 ft. (8 m)	0700300557
TXH-201, 13 ft. (4 m)	0700300588		
TXH-201, 26 ft. (8 m)	0700300560		
TXH-201F, 13 ft. (4 m)	0700300599		
Water-Cooled Torches – OKC50 Connector [2 in. (50 mm)]			
TXH-251w, 13 ft. (4 m)	0700300561	TXH-401w, 13 ft. (4 m)	0700300565
TXH-251w, 26 ft. (8 m)	0700300563	TXH-401w, 26 ft. (8 m)	0700300567
TXH-251wF, 13 ft. (4 m)	0700300562	TXH-401w HD, 13 ft. (4 m)	0700300566
TXH-251wF, 26 ft. (8 m)	0700300564	TXH-401w HD, 26 ft. (8 m)	0700300568
Remote Control Torches – OKC50 Connector [2 in. (50 mm)]			
TXH-121r, 13 ft. (4 m)	0700300620	TXH-201Fr, 26 ft. (8 m)	0700300631
TXH-121r, 26 ft. (8 m)	0700300622	TXH-251wr, 13 ft. (4 m)	0700300632
TXH-121Fr, 13 ft. (4 m)	0700300621	TXH-251wr, 26 ft. (8 m)	0700300634
TXH-151r, 13 ft. (4 m)	0700300624	TXH-251wFr, 13 ft. (4 m)	0700300633
TXH-151r, 26 ft. (8 m)	0700300626	TXH-251wFr, 26 ft. (8 m)	0700300635
TXH-151Fr, 13 ft. (4 m)	0700300625	TXH-401wr, 13 ft. (4 m)	0700300636
TXH-151Fr, 26 ft. (8 m)	0700300627	TXH-401wr, 26 ft. (8 m)	0700300638
TXH-201r, 13 ft. (4 m)	0700300628	TXH-401wr HD, 13 ft. (4 m)	0700300637
TXH-201r, 26 ft. (8 m)	0700300630	TXH-401wr HD, 26 ft. (8 m)	0700300639
TXH-201Fr, 13 ft. (4 m)	0700300629		

<sup>1</sup>OKC25C F = Flexible. V = Gas Valve.

## Remote Controls



### MTA1 CAN

- CAN based remote control for control panels A2, A4, T4, T6, M2, MA4, MA6, U6, and Aristo U8<sub>2</sub> Plus

#### Ordering Information

MTA1 CAN	0459491880
----------	------------



### M1

- Analogue standard MIG for control panels M10, M12, M13, M13i, M14 and Warrior Feed
- Stick/TIG: Wire feed and voltage control

#### Ordering Information

M1	0459491895
----	------------



### M1 10Prog CAN

- CAN based Synergic MIG for control panels MA6, U6 and AristoPendant U8<sub>2</sub> Plus
- Stick/TIG: Memory 1-10 and voltage trim =/-

#### Ordering Information

M1 10Prog CAN	0459491882
---------------	------------



### AT1 Coarse

- Analogue standard Stick and TIG for power sources with remote outlet - Warrior 400i MV/500i
- Stick/TIG: Current control

#### Ordering Information

AT1 Coarse	0459491896
------------	------------



### AT1 CAN

- CAN based standard Stick and TIG for control panels A2, A4, T4, T6, U6, U8<sub>2</sub> Plus
- Stick/TIG: Current control

#### Ordering Information

AT1 CAN	0459491883
---------	------------



### AT1 Coarse/Fine

- Analogue standard Stick and TIG for power sources with remote outlet - Warrior 400i MV/500i
- Stick/TIG: Current control, coarse/fine

#### Ordering Information

AT1 Coarse/Fine	0459491897
-----------------	------------



### AT1 Coarse/Fine CAN

- CAN based standard Stick and TIG for control panels A2, A4, T4, T6, U6, U8<sub>2</sub> Plus
- Stick/TIG: Current control, coarse/fine

#### Ordering Information

AT1 Coarse/Fine CAN	0459491884
---------------------	------------



### Remote Adaptors for CAN Based Systems

- For analog Stick and TIG remote controls. For analog MIG remote controls and 3-step program switch RS3

#### Ordering Information

RA 12 for Stick and TIG	0459491910
RA T1 TIG remote torch 12 pole <sup>1</sup>	0459491912
RA T1 TIG remote torch 10 pole <sup>1</sup>	0459491913

<sup>1</sup>Includes holder and cable.

## Remote Controls



### Foot Control - GTAW

- Complete with 16.5 ft (5 m) rubber cable and equipped with 12-pole Burndy



### Remote Control MMA1

- MMA 1 is equipped with 1 potentiometers for current setting
- Includes 33 ft. (10 m) rubber cable equipped with a 12-pole Burndy and a metal hook

#### Ordering Information

FS003-B analog remote 25 ft. (7.6 m)	0558008905
--------------------------------------	------------

#### Ordering Information

MMA1	0349501024
------	------------

#### Ordering Information

##### Additional Remote Controls

HC-3B hand pendant control (cc-Amps/cv-Volts)	33838
TC-2B torch control	33839
FC-5C foot control	0558004234
FC-5B EHD foot control	33841

## Twist Lock Connectors

#### Ordering Information

##### OKC50 Connectors [2 in. (50 mm)]

Male for 1/0 to 4/0 cable	13792513
Female for 1/0 to 4/0 cable	13735631
Male for #2 AWG to 1/0 cable	13733936
Female for #2 AWG to 1/0 cable	13735632
Quick connector with 1/2 in. threaded stud	13735501
Tee connector (1 male, 2 female)	13792804

## Interconnection Cables

#### Ordering Information

##### 10 Pole

0.8 ft. (0.25 m)	0459960883
16.4 ft. (5 m)	0459960880
33 ft. (10 m)	0459960881
82 ft. (25 m)	0459960882
16.4 ft. (5 m) HD	0459960880
33 ft. (10 m) HD	0459960881
82 ft. (25 m) HD	0459960882

##### 12 Pole

0.8 ft. (0.25 m) CAN	0459554884
16.4 ft. (5 m) CAN	0459554880
33 ft. (10 m)	0459554881
49 ft. (15 m) CAN	0459554882
66 ft. (20 m) CAN	0459554883
16.4 ft. (5 m) ANALOG 23 p	0459553880
16.4 ft. (5 m) ANALOG 12 p	0459552880
33 ft. (10 m) ANALOG 12 p	0459552881
49 ft. (15 m) ANALOG 12 p	0459552882
82 ft. (25 m) ANALOG 12 p	0459552883

## Electrode Holders



A-316

A-732

A-14

### TwecoTong A-Series

- TwecoTong Electrode Holders are designed to mechanically hold a welding electrode in position
- Reversible Top & Bottom Insulators are easy to replace
- Efficient 6-Position Jaw Patterns
- Ball Point Cable Connections
- Fully Insulated & Protected Springs
- Heavy Duty Copper Alloy

### Ordering Information

Amperage	Body Alloy	Electrode	Cable	Length	Stock No.
200	Copper Alloy	5/32" (4.0 mm)	2/0 (67.4 mm)	8-1/2" (216 mm)	9110-1101
200	Copper Alloy	5/32" (4.0 mm)	2/0 (67.4 mm)	8-1/2" (216 mm)	9110-1109
250	Copper Alloy	3/16" (4.8 mm)	2/0 (67.4 mm)	9-1/4" (235 mm)	9110-1102
250	Copper Alloy	3/16" (4.8 mm)	2/0 (67.4 mm)	9-1/4" (235 mm)	9110-1110
300	Copper Alloy	7/32" (5.6 mm)	2/0 (67.4 mm)	10" (254 mm)	9110-1103
300	Copper Alloy	7/32" (5.6 mm)	2/0 (67.4 mm)	10" (254 mm)	9110-1111
350	Copper Alloy	1/4" (6.4 mm)	4/0 (107 mm)	11" (279 mm)	9110-1104
400	Copper Alloy	1/4" (6.4 mm)	4/0 (107 mm)	12" (305 mm)	9110-1105
500	Copper Alloy	3/8" (9.5 mm)	4/0 (107 mm)	13-1/4" (336 mm)	9110-1106

\* Clamshell packaging. Sold individually or master packed in quantities of 12 each.

\*\* Sold in Master Pack Boxed Quantities of 24.



T-532

T-316

T-732

### TwecoTong T-Series

- Ergonomic Handle has 12-degree angle
- Efficient 6-Position Jaw Patterns to hold the welding electrode in position
- Double Ball Point Cable Connections accept up to 2/0 welding cable
- Rugged & Reliable Design with operator appeal
- Designed to meet IEC 60974-11
- Fully Insulated & Protected Springs

### Ordering Information

Amperage	Body Alloy	Electrode	Cable	Length	Stock No.
200	Copper Alloy	5/32" (4.0 mm)	2/0 (67.4 mm)	9-1/2" (241 mm)	9110-1122
200	Copper Alloy	5/32" (4.0 mm)	2/0 (67.4 mm)	9-1/2" (241 mm)	9110-1131
250	Copper Alloy	3/16" (4.8 mm)	2/0 (67.4 mm)	9-1/2" (241 mm)	9110-1123
250	Copper Alloy	3/16" (4.8 mm)	2/0 (67.4 mm)	9-1/2" (241 mm)	9110-1132
300	Copper Alloy	7/32" (5.6 mm)	2/0 (67.4 mm)	10" (254 mm)	9110-1124
300	Copper Alloy	7/32" (5.6 mm)	2/0 (67.4 mm)	10" (254 mm)	9110-1133

\* Sold in Master Pack Boxed Quantities of 24.

\*\* Sold Individually



4TT

### TwecoTite

- Tweco-Tite Electrode Holders with Fully Insulated Body designed for effortless installation of electrodes
- 45 Degree Angled Head holds the welding electrode in place

### Ordering Information

Amperage	Electrode	Cable	Stock No.
400	1/4" (6.4 mm)	4/0 (107 mm)	9110-1105

# Ground Clamps

EASY FIND GUIDE												
Ground Clamps	Application	Amperage Range								Recommended Model		
		200	300	400	500	600	700	800	1500		2000	
Plate		■									FGC 200	
		■	■								FGC 300	
		■	■	■							FGC 500	
		■	■	■	■						SGC 300	
		■	■	■	■	■					SGC 500	
	Pipe		■									GC 200
			■	■								GC 300
			■	■	■							GC 500
			■									SMGC 200
			■	■								SMGC 300
		■	■	■							SMGC 600	
Rotary			■								GCRG 140	
			■	■							RG 140	
			■	■	■						RG 230	
			■	■	■	■					RG 240	
			■	■	■	■	■				RG 440	
			■	■	■	■	■	■			RG 640	

Model	Output			Cable Connection	Process			Application			
	Current (Amps)	Jaw Opening	No. of Heads		Plate	Pipe	Rotary	Light Duty Fab	Med. Duty Fab	Heavy Duty Fab	Extra Heavy Duty Fab
<b>FGC 200</b>	200	2" (50.8 mm)	--	Ball-Point thru 1/0	■			■			
<b>FGC 300</b>	300	3-1/2" (88.9 mm)	--	Ball-Point thru 3/0	■			■	■		
<b>FGC 500</b>	500	3-3/4" (95.3 mm)	--	Ball-Point thru 4/0	■				■	■	
<b>SGC 300</b>	300	2" (50.8 mm)	--	1/2" Stud	■			■	■		
<b>SGC 500</b>	500	2" (50.8 mm)	--	1/2" Stud	■				■	■	
<b>GC 200</b>	200	3" (76.2 mm)	--	Ball-Point thru 1/0		■		■			
<b>GC 300</b>	300	4" (101.0 mm)	--	Ball-Point thru 3/0		■		■	■		
<b>GC 500</b>	500	5-1/4" (133.0 mm)	--	Ball-Point thru 4/0		■			■	■	
<b>SMGC 200</b>	200	--	--	Ball-Point thru 1/0		■		■			
<b>SMGC 300</b>	300	--	--	Ball-Point thru 3/0		■		■	■		
<b>SMGC 600</b>	600	--	--	Ball-Point thru 4/0		■				■	
<b>GCRG 140</b>	400	--	1	1 thru 4/0			■		■	■	
<b>RG 140</b>	400	--	1	1 thru 4/0			■		■	■	
<b>RG 230</b>	600	--	1	2 thru 3/0			■			■	
<b>RG 240</b>	800	--	1	2 thru 4/0			■			■	■
<b>RG 440</b>	1500	--	2	4 thru 4/0			■				■
<b>RG 640</b>	2000	--	3	6 thru 4/0			■				■

ARC ACCESSORIES

## Ground Clamps

Ideal for most Light to Medium Duty fabrication needs

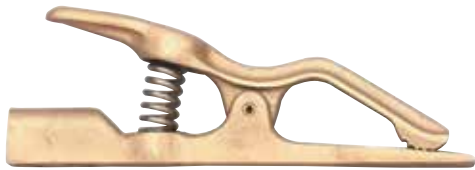

Flat Jaw Copper Ground Clamps

- Ideal for plate grounding

Ordering Information				
Amperage	Jaw Opening	Cable	Length	Stock No.
200	5/8" - Depth 2" (15.9 mm - 50.8 mm)	Ball-Point thru 1/0	5" (127 mm)	9205-1320
300	1" - Depth 3-1/2" (25.4 mm - 88.9 mm)	Ball-Point thru 3/0	7-14" (184 mm)	9205-1330
500	1-1/4" - Depth 3-3/4" (31.8 mm - 95.3 mm)	Ball-Point thru 4/0	9-1/4" (234 mm)	9205-1350



Steel Ground Clamps

- Ideal for plate grounding and lower amperage needs

Ordering Information				
Amperage	Jaw Opening	Cable	Length	Stock No.
300	2" - Depth 1-3/4" (50.8 mm - 44.4 mm)	1/2" Stud Connection	9" (228 mm)	9205-1230
500	2" - Depth 1-3/4" (50.8 mm - 44.4 mm)	1/2" Stud Connection	9" (228 mm)	9205-1250



Copper Ground Clamps

- Ideal for pipe grounding

Ordering Information				
Amperage	Jaw Opening	Cable	Length	Stock No.
200	1" - Depth 3" (25.4 mm - 76.2 mm)	Ball-Point thru 1/0	6" (157 mm)	9205-1120
300	1-1/2" - Depth 4" (38.1 mm - 101.0 mm)	Ball-Point thru 3/0	8-1/2" (216 mm)	9205-1130
300	2" - Depth 1-3/4" (50.8 mm - 44.4 mm)	Ball-Point thru 3/0	8-1/2" (216 mm)	9205-1131
500	2" - Depth 1-3/4" (50.8 mm - 44.4 mm)	Ball-Point thru 4/0	10" (254 mm)	9205-1150



## Ground Clamps

Ideal for most heavy-duty fabrication needs



RG-440

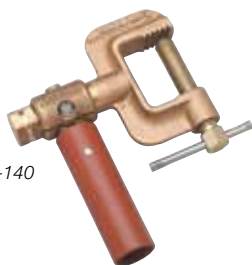

GCRG-140

### Tweco Roto-Ground Clamps

- Ideal for high amperage grounding
- Highly efficient device for grounding weldments while being rotated on turning rolls or positioners
- The 2" shaft shoulders up to a steel nut which the user welds to the rotating work or fixture
- Tweco Roto-Grounds have no brushes, springs or mercury
- A simple tension adjusting bolt provides maximum efficiency

#### Ordering Information

Amperage	Cable	Number of Heads	Shaft Stud	Length	Stock No.
400	1 - 4/0	1	3/4" NC	--	9210-1314
400	1 - 4/0	1	3/4" NC	8" (203 mm)	9250-1114
600	2 - 3/0	1	1-1/8" NC	10-1/4" (260 mm)	9250-1123
800	2 - 4/0	1	1-3/8" NC	10-5/8" (270 mm)	9250-1124
1500	4 - 4/0	2	1-3/8" NC	10-5/8" (270 mm)	9250-1144
2000	6 - 4/0	3	1-3/8" NC	10-5/8" (270 mm)	9250-1164



WCRG-1200



GC-600-75

### Tweco Roto-Work Clamps

- Tweco Roto-Work Ground Clamps are designed primarily to work in conjunction with the Tweco Roto-Ground Device, however they may also be used for other high amperage grounding applications
- The Roto-Ground shaft screws into the tapped back of the Roto-Work Clamp
- The clamp is quickly attached or moved from one rotation weldment or fixture to the other without removing the Roto-Ground from it, saving on welding down time
- Roto-Work Clamps are made from a copper alloy
- They come in 600, 1200 and 2000 ampere capacity
- Number WCRG-2000 has two tightening screws
- Number WCRG-600 works only with No. RG-230 due to its smaller shaft size
- Large tightening screws and ample contact surface area provide cool, efficient operation

#### Ordering Information - Tweco Roto-Work Ground Clamps

Amperage	Fits Roto-Ground	Clamp Contact	Throat Height	Throat Depth	Overall Height	Overall Width	Tapped For	Stock No.
600	RG-230	6-1/4 sq in	2-1/2" (63.5 mm)	2-1/2" (63.5 mm)	5-3/4" (146.0 mm)	2-1/2" (63.5 mm)	1-1/8" NC	9255-1106
1200	RG-240/440	9 sq in	3" (76.2 mm)	3" (76.2 mm)	6-3/4" (171.0 mm)	3" (76.2 mm)	1-3/8" NC	9255-1112
2000	RG-440/640	12 sq in	3" (76.2 mm)	3" (76.2 mm)	6-3/4" (171.0 mm)	4" (102.0 mm)	1-3/8" NC	9255-1120

#### Ordering Information - Tweco Ground Clamps with Cap Screws

Amperage	Jaw Opening	Cable	Stock No.
500	2-1/2" - Depth 1-3/8" (63.5 mm - 34.9 mm)	1/2" Cap Screw	9210-1150
600	2-1/2" - Depth 1-3/8" (63.5 mm - 34.9 mm)	3/4" Cap Screw	9255-1075
600	2-1/2" - Depth 1-3/8" (63.5 mm - 34.9 mm)	Double Ball-Point	9210-1201
600	2-1/2" - Depth 1-3/8" (63.5 mm - 34.9 mm)	Tweco Male Plug	9210-1202

ARC  
ACCESSORIES

## Ground Clamp Accessories



RG-240-11

A-14-24

2-5



8Z-L



138

### Roto-Ground Accessories

#### Ordering Information

Lubricating Cup	9922-2129
Ball-Point Cable Connection Screw	9910-2424
Special Shaft Lubricant	9900-1123
Fibre Cover Screw	9940-2125

### Tweco Shaft Lubricant

- An electrical conductive grease to be used as a lubricant for roto-grounds and may be used when making mechanical connections with copper or aluminum cables
- Effective as a lubricant on sliding or moving electrical contacts such as switches and rotating grounding devices
- Apply generously to contact area from 1 oz (29.6 mL) or 8 oz (237.0 mL) plastic bottles. Reduce electrical resistance by as much as 40 to 50%

#### Ordering Information

1 oz (29.6 mL) Plastic Squeeze Bottle	9900-1123
8 oz (237.0 mL) Plastic Squeeze Bottle	9900-1124

### Work Clamp Adapter

#### Ordering Information

Work Clamp Adapter W/ 1-1/8"-7 UNC 2A OD Thread & 5/8"-11 UNC-2A ID Thread - Fits WCRG-600 Roto-Work Clamp	9922-2018
Work Clamp Adapter W/ 1-3/8"-6 UNC 2A OD Thread & 5/8"-11 UNC-2A ID Thread - Fits WCRG-1200 & WCRG-2000 Roto-Work Clamps	9922-2038

### "C" Type Clamp Parts

#### Ordering Information

Cap Screw - 1/2" x 3/4" NC	9920-2100
Fitting-No.2 Male Plug (threaded 1/2" NC)	9920-2102
Fitting-Double Ball-Point (threaded 1/2"NC)	9920-2103
Cover	9940-2124

## Switchable Magnetic Work Holding Products

### Switchable Magnetic Ground Clamps



Easy Connect & Easy Release On/Off Knob

9255-1060



Just Turn Off & Wipe Away Debris

9255-1061



Cuts Set Up Time

9255-1062

#### Ordering Information

Amperage	Height	Width	Length	Weight	Std. Pkg.	Stock No.
200	2.5" (63.5 mm)	1.58" (40.1 mm)	2.19" (55.6 mm)	0.38 lbs	10	9255-1060
300	2.26" (57.4 mm)	1.58" (40.1 mm)	2.7" (68.6 mm)	0.61 lbs	10	9255-1061
600	2.6" (66.0 mm)	2.83" (71.9 mm)	4.09" (103.9 mm)	2.0 lbs	5	9255-1062

### Switchable Magnetic Multi-Angle Clamps



9255-1064



9255-1063

- Work-holding switchable magnetic products
- Holds flat, round, odd shaped products
- Perfect for cutting, drilling, grinding, beveling

#### Ordering Information

Description	Capacity/Power	Stock No.
Switchable Magnetic Multi Angle 300	Magnetic Power 150 lbs	9255-1064
Switchable Magnetic Multi Angle 400	Holding Power 400 lbs	9255-1063

### Switchable Magnetic Pick & Pack Lifters & Hooks



9255-1065



9255-1066

- Products to pick, place, slide and reposition steel base metals
- Ideal for small steel handling, dragging sheet, picking and pulling parts out of burn table or handling scrap

#### Ordering Information

Description	Capacity/Power	Stock No.
Switchable Magnetic Lifter Manual 60	Recommended Lift Capacity 60 lbs	9255-1065
Switchable Magnetic Lifter Hook 600	Lift Capacity 200 lbs	9255-1066

### Switchable Magnetic Right-Angle (90°) Clamp



9255-1067

- Holds base plate – flat or round – at 90-degree angles for perfect positioning for code work and precision welding or cutting
- Ideal for automated tables used in plasma cutting

#### Ordering Information

Description	Capacity/Power	Stock No.
Switchable Magnetic Right Angle 400	Holding Power 400 lbs	9255-1067

## Cable Lugs

EASY FIND GUIDE								
Cable Lugs	Style	Amperage Range					Recommended	
		50	75	150	225	250		325
Cable Lugs	Crimp Lugs for Welding Cable	50-150						T-62
		50-225						T-120
		50-325						T-3040
		50-325						T-40HD
	Crimp Lugs for Power Cable	50-75						T-810
		50-75						T-68
		50-75						T-46
	Ball-Point Lugs without Insulated Cover	50-150						10-45
		50-150						10-180
		50-325						40-45
	Ball-Point Lugs with Insulated Cover	50-150						40-180
		50-150						10-45C
50-325							10-180C	
50-325							40-45C	
Heavy Duty Lugs	50-325						40-180C	
	50-325						140-HD-180	
	50-325						140-HD-180C	
							240-HD-180	

Crimp Lugs



Ball-Point Lugs



Heavy Duty Lugs



## Cable Lugs

TwecoLugs - Crimp or Solder Type Lugs (Use Tweco "Lug-Set")



TwecoLugs (Crimp Lugs) for Welding Cable

Ordering Information					
Cable	Amp Rating	Stud Hole	I.D. Solder Socket	Std Pkg	Stock No.
6 thru 2	150	17/32" (13.5 mm)	.461" (11.7 mm)	50	9520-1115
6 thru 2	150	17/32" (13.5 mm)	.461" (11.7 mm)	5	9520-1104
1 thru 2/0	225	17/32" (13.5 mm)	.559" (14.2 mm)	50	9520-1116
1 thru 2/0	225	17/32" (13.5 mm)	.559" (14.2 mm)	5	9520-1105
3/0 & 4/0	250	17/32" (13.5 mm)	.660" (16.7 mm)	25	9520-1117
3/0 & 4/0	250	17/32" (13.5 mm)	.660" (16.7 mm)	5	9520-1107
4/0 Heavy Duty	325	21/32" (17.7 mm)	.776" (19.7 mm)	25	9520-1118
4/0 Heavy Duty	325	21/32" (17.7 mm)	.776" (19.7 mm)	5	9520-1109



TwecoLugs (Crimp Lugs) for Power Cable

Ordering Information					
Cable	Amp Rating	Stud Hole	I.D. Solder Socket	Std Pkg	Stock No.
8 thru 10	50	13/64" (5.2 mm)	.238" (6.1 mm)	10	9520-1101
6 thru 8	70	21/64" (8.3 mm)	.289" (7.3 mm)	10	9520-1102
4 thru 6	90	21/64" (8.3 mm)	.347" (8.8 mm)	10	9520-1103

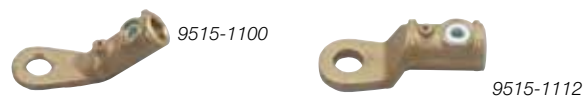

Ball-Point Lugs without Insulated Cover

Ordering Information					
Description	Cable	Amp Rating	Stud Hole	Std Pkg	Stock No.
45° Angle	thru 1/0	150	17/32" (13.5 mm)	1	9515-1100
180° Offset	thru 1/0	150	17/32" (13.5 mm)	1	9515-1102
45° Angle	thru 4/0	325	17/32" (13.5 mm)	1	9515-1110
180° Offset	thru 4/0	325	17/32" (13.5 mm)	1	9515-1112



Ball-Point Lugs with Insulated Cover

Ordering Information					
Description	Cable	Amp Rating	Stud Hole	Std Pkg	Stock No.
45° Angle	thru 1/0	150	17/32" (13.5 mm)	1	9515-1101
180° Offset	thru 1/0	150	17/32" (13.5 mm)	1	9515-1103
45° Angle	thru 4/0	325	17/32" (13.5 mm)	1	9515-1111
180° Offset	thru 4/0	325	17/32" (13.5 mm)	1	9515-1113



Heavy Duty Mechanical Ball-Point Lugs

Ordering Information					
Description	Cable	Amp Rating	Stud Hole	Length	Stock No.
180° Offset	3/0 & 4/0	325	21/32" (16.7 mm)	4-3/8" (111 mm)	9515-1120
With Insulated Cover - 180° Offset	3/0 & 4/0	325	21/32" (16.7 mm)	5-1/2" (140 mm)	9515-1121
180° Offset	3/0 & 4/0	325	21/32" (16.7 mm)	4-5/8" (131 mm)	9515-1122

ARC ACCESSORIES

## Cable Connectors



### MPC Series

Positive-CAM Mechanical Connection - zinc plated type cable & cover screws

### MPC Connectors

- Tweco MPC connectors provide a positive cam action, which optimizes interface between connector halves
- Equipped with heat and oil resistant covers
- Furnished with zinc plated cover and ball-point cable screws
- Interchangeable with older Tweco MBP Connectors
- The Whip Cable Connector is used when down sizing cable to an electrode holder
- It is a No. 2 male connector with cable hole sized to fit 4, 2, 1 or 1/0 cable
- The 2-1-MPC will fit any No. 2 or No. 4 female connector

### Ordering Information

Description	Type Cable Connection	Cable Capacity	Standard Package	Stock No.
Complete Connection	Single Ball-Point	4, 2, 1	Pkg. 1 ea. Male & Female	9425-1100
Male Half	Single Ball-Point	4, 2, 1	Pkg. 2 ea. Male Only	9425-1110
Female Half	Single Ball-Point	4, 2, 1	Pkg. 2 ea. Female Only	9425-1120
Complete Connection	Single Ball-Point	1/0, 2/0, 3/0	Pkg. 1 ea. Male & Female	9425-1200
Complete Connection	Single Ball-Point	1/0, 2/0, 3/0	Pkg. 1 ea. Male & Female	9425-1201
Male Half	Single Ball-Point	1/0, 2/0, 3/0	Pkg. 2 ea. Male Only	9425-1210
Male Half	Single Ball-Point	1/0, 2/0, 3/0	Pkg. 2 ea. Male Only	9425-1211
Female Half	Single Ball-Point	1/0, 2/0, 3/0	Pkg. 2 ea. Female Only	9425-1220
Female Half	Single Ball-Point	1/0, 2/0, 3/0	Pkg. 2 ea. Female Only	9425-1221
Complete Connection	Double Ball-Point	3/0 or 4/0	Pkg. 1 ea. Male & Female	9425-1400
Complete Connection	Double Ball-Point	3/0 or 4/0	Pkg. 1 ea. Male & Female	9425-1401
Male Half	Double Ball-Point	3/0 or 4/0	Pkg. 2 ea. Male Only	9425-1410
Male Half	Double Ball-Point	3/0 or 4/0	Pkg. 2 ea. Male Only	9425-1411
Female Half	Double Ball-Point	3/0 or 4/0	Pkg. 2 ea. Female Only	9425-1420
Female Half	Double Ball-Point	3/0 or 4/0	Pkg. 2 ea. Female Only	9425-1422
Whip Connection	Single Ball-Point	4, 2, 1, 1/0	Pkg. 2 ea.	9425-1140

\*Sold in Master Pack Boxed Quantities of 48.

\*\*Sold in Master Pack Quantities of 24.

† Clamshell packaging. Sold individually or master packed in quantities of 24 each.

‡ Clamshell packaging. Sold individually or master packed in quantities of 12 each.

### Replacement Tapered Machine Plugs Ball-Point Connection



### Ordering Information

Taper Length	Taper Dimensions	Cable	Stock No.
1-1/8" (28.6 mm)	21/64" to 23/64" (8.3 mm x 9.1 mm)	4 thru 1	9505-1800
1-1/8" (28.6 mm)	21.64" to 23/64" (8.3 mm x 9.1 mm)	1/0 thru 3/0	9505-1801

### Cable Connector Replacement Parts

MPC Series Positive-CAM - Zinc plated type cable & cover screws

### Ordering Information

Description	Stock No.
Insulating Cover Only, All 1-MPC	9940-2103
Insulating Cover Only, All 2 & 4 MPC	9940-2124
Cable Connection Screw, Zinc Plated, All 2-MPC	9910-2124
Cable Connection Screw, Zinc Plated, All 4-MPC	9910-2424
Cover Screw, Zinc Plated, All MPC Connectors	9940-2125



### Panel Receptacles

For use with MPC Connectors

### Ordering Information

Cable Fitting Type	Fits Tweco Connector	For Cable Size	Cable Attachment	Stock No.
Ball-Point	No. 1	4, 2, 1	5/16" Ball-Point (7.9 mm)	9580-1100
Threaded	No. 1	4, 2, 1, 1/0	5/16" Thread. Stud (7.9 mm)	9580-1101
Threaded	No. 2, 4	1/0, 2/0, 3/0	3/8" Thread. Stud (9.5 mm)	9580-1102
Ball-Point	No. 2, 4	1/0, 2/0, 3/0	9/16" Ball-Point (14.3 mm)	9580-1103
Threaded	No. 2, 4	1/0, 2/0, 3/0	1/2" - 20 Thread. Stud (12.7 mm)	9580-1104

## Splicers, Terminals and Accessories

### Copper Cable Splicers



9610-1103

Ordering Information				
Cable	Amp Rating	Tube I.D.	Standard Package	Stock No.
6 thru 2	150	.461" (11.7 mm)	50	9610-1105
6 thru 2	150	.461" (11.7 mm)	5	9610-1101
1 thru 2/0	225	.599" (15.2 mm)	5	9610-1102
3/0 thru 4/0	250	.660" (16.8 mm)	5	9610-1103
4/0 Heavy Duty	325	.776" (19.7 mm)	5	9610-1104

### Ball-Point Cable Splicers



9605-1103

Ordering Information				
Cable	Amp Rating	Cable Fitting Type	Standard Package	Stock No.
4 thru 1/0		Ball-Point	1	9605-1101
1/0 thru 3/0		Ball-Point	1	9605-1103
2/0 thru 4/0		Double Ball-Point	1	9605-1105

### Tweco Terminals

9505-1152



9505-1811



### Tweco Terminals and TwecoLugs

Tweco Screw-On Terminals Fits Terminal Size 1/2" (12.7 mm) NC

Ordering Information	
Accepts Tweco Connector Number	Stock No.
No. 2 & No. 4 Male Half	9505-1152

### Receptacle Conversion Adapters

Ordering Information		
Fits Cam Locking Machine Receptacle	Fits Tweco Male Plug Ends	Stock No.
Large - 11/16" I.D. (17.5 mm)	No. 2-MPC, 4-MPC	9505-1811

### Tweco Female Terminals

Stud Hole Size 17/32" (13.5 mm)



9510-1100



9510-1101

Ordering Information			
Description	Accepts Male Ends	Standard Package	Stock No.
45° Angle	1-MPC	1	9510-1100
180° Offset	1-MPC	1	9510-1101
45° Angle	2-MPC, 4-MPC	1	9510-1110
180° Offset	2-MPC, 4-MPC	1	9510-1111

### Accessories

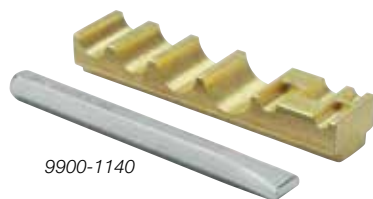

9900-1140

### Tweco "Lug-Set"

#### Block & Punch

For use with TwecoLugs

Ordering Information	
Description	Stock No.
Block & Punch	9900-1140

### Jacket Stripping Cable

#### Cutting Hand Tool

For use with lugs with an insulated cover



9900-1190

Ordering Information	
Description	Stock No.
Tweco Cable Cutting Hand Tool	9900-1190

# // GAS EQUIPMENT







**CONTENTS**

**GAS OUTFITS**

Journeyman® EDGE 2.0 ..... 93  
 Contender® EDGE 2.0 ..... 93  
 Journeyman® II EDGE 2.0 ..... 93  
 Performer® EDGE 2.0 ..... 93  
 Medalist® 350 ..... 94  
 Journeyman® Select EDGE 2.0 ..... 94  
 Medalist® 250 ..... 94  
 Cutter™ Select ST2600FC EDGE 2.0..... 94  
 Cutter™ Select ST1000FC ..... 95  
 Portable Tote Kit - 100FC Torch Handle/CA 1350 Cutting Attachment .. 95  
 Cutter™ Select ST900FC EDGE 2.0..... 95  
 Portable Tote Kit - W 270FC-V Torch Handle/CA 270-V Cutting Attachment... 95  
 G150 Portable Tote ..... 96  
 Powder Spray Torch Kit..... 96  
 Fire-Stick Torch Kit ..... 96

**GAS CONTROL**

Model Numbering Explanation ..... 97  
 How to read the Flow Data Charts ..... 98  
 Pressure Drop Reference Charts..... 99  
 Regulator Selection Guide - by Gas Service..... 100  
 EDGE™ Series Color Coding by Gas Type..... 101  
 Single Stage Regulators..... 107  
 Two Stage Regulators ..... 107  
 EDGE™ Series..... 108  
 EDGE™ 2.0 Series Regulators ..... 108  
 ESS7..... 109  
 ESS42 EDGE 2.0 ..... 109  
 ESS32 EDGE 2.0 ..... 110  
 ESS32-PFH-800..... 110  
 SR 450..... 111  
 SR 350..... 111  
 SR 250..... 112  
 G350 ..... 112  
 G250 ..... 113  
 G150..... 113  
 VTS 700 ..... 114  
 VTS 250 ..... 114  
 ETS4 Series ..... 115  
 EHP Series ..... 115  
 SR 4..... 116  
 ELC4..... 117  
 ESL4 ..... 117  
 EST4 ..... 118  
 SR 310/311/312 ..... 118  
 Flow Meter ..... 119  
 HRF 2400 ..... 120

DFM 150..... 120  
 HSR & HVTS..... 121  
 GRF 400 ..... 122  
 TPR 250 Purging Regulator ..... 122  
 HRF 1400 ..... 122  
 MECO High Pressure ..... 122  
 Handles & Cutting Attachments ..... 123  
 400 Series WH 411C Torch Handle..... 124  
 CA 411-1 Cutting Attachment ..... 124  
 CA 411-3 Cutting Attachment ..... 124  
 300 Series HD 310C Torch Handle..... 124  
 300 Series WH 315FC+ Torch Handle..... 125  
 J Series - J-28 & J-40 Torch Handles..... 125  
 100 Series 100FC Torch Handle..... 125  
 CA 2460+ Cutting Attachment ..... 126  
 CA 1260 Cutting Attachment ..... 126  
 CA 1350 Cutting Attachment ..... 126

**NOZZLES**

Type 55/55-1 Multi-Flame Heating Nozzles ..... 128  
 Type 55 Components ..... 128  
 MFN/MFN-1 Heating Nozzles ..... 129  
 MFA/MFA-1 Heating Nozzles ..... 129  
 Series 1 Heating Tips ..... 130  
 CHT Adaptor ..... 130  
 Welding Nozzles ..... 130  
 Elbow Tips..... 131  
 UM Series Universal Mixers ..... 131  
 RTE Series Replaceable Tip Ends..... 131  
 RTEN Series ..... 131  
 FE Series Flexible Elbow ..... 132  
 UN Series Universal Nozzle..... 132  
 DFE Series Dual Flexible Elbows ..... 132  
 Replaceable Tip Ends..... 132

**GAS TORCHES**

Victor “Universal Torches” ..... 133  
 HC 1500C..... 134  
 HC 1200C Series..... 135  
 Bulldog™ - HC 1100C..... 136  
 ST 2600FC Series ..... 137  
 ST 1000FC Series ..... 137  
 ST 900FC Series ..... 138  
 ST 400C Series..... 138  
 Victor Machine Torches ..... 139  
 MT 200 Series ..... 139  
 Rugged Brass Torch head..... 139  
 MT 300 Series ..... 139  
 Pre-Drilled 1.38" (35.1 mm) Diameter Barrels ..... 139

MT 300 Series .....	140
MT 5 .....	140
MT 200 Series .....	140
MT 1065.....	140
Gear Racks.....	140

## CUTTING TIPS

Series 1 – Acetylene Cutting Tips .....	142
Victor Series 1 Type 101 30° .....	143
Victor Series 1 Type 101-L .....	143
Victor Series 1 Type 108.....	143
G-Series Series 1 Type 108.....	143
Victor Series 1 Type 112.....	144
Victor Series 1 Type 118 Round).....	144
G-Series Series 1 Type 118 (Round) .....	144
Victor Series 1 Type 118 (Sides Cutaway).....	144
G-Series Series 1 Type 118 (Sides Cutaway).....	144
Series 1 – Propylene Cutting Tips .....	145
Victor Series 1 Type GPP .....	146
G-Series Series 1 Type GPP .....	146
G-Series Series 1 Type GPP-P (Plated) .....	147
Victor Series 1 Type HPP .....	147
G-Series Series 1 Type HPP .....	147
Victor Series 1 Type MTHP .....	148
G-Series Series 1 Type MTHP.....	148
Victor Series 1 Type 303MP .....	149
G-Series Series 1 Type 303MP .....	149
Victor Series 1 Type BTMP .....	149
Victor Series 1 Type GTB .....	150
Victor Series 1 Type 318MP .....	150
G-Series Series 1 Type 318MP .....	150
Series 1 – LP Cutting Tips.....	151
Victor Series 1 Type 200 .....	152
Victor Series 1 Type 207 .....	152
Victor Series 1 Type 244 .....	152
Victor Series 1 Type MCN .....	152
Victor Series 1 Type GPN.....	153
G-Series Series 1 Type GPN .....	153
G-Series Series 1 Type GPN (Plated).....	154
Victor Series 1 Type MTHN .....	154
G-Series Series 1 Type MTHN.....	155
Victor Series 1 Type HPN.....	155
G-Series Series 1 Type HPN .....	156
Victor Series 1 Type BTN.....	156
Victor Series 1 Type CSN .....	156

## SAFETY ACCESSORIES

Flashback Arrestors and Check Valves.....	157
FlameBuster™ High Flow .....	158
FlameBuster™ .....	158
FlameBuster™ Plus .....	159
Flashback Arrestor with Kwik-Connect Coupling Components FBP-1... ..	159
Flashback Arrestors.....	159
Reverse Flow Check Valves .....	159
Built-in Flash Arrestor .....	159
Vanguard™ Flashback Arrestor .....	159
Kwik-Connect .....	159



**1913**

The history of Victor begins in 1913 in San Francisco. The founder of Victor, Mr L.W. Stettner suffered a serious injury. A welder by trade, Stettner lost an eye during a welding accident, and following recovery, he was determined to design safer welding equipment and accessories – the birth of the Victor Torch.



**1941-1945**

Victor torches are integral to the war effort in World War II.



**1918**

The Victor handle was the first to feature a tube within a tube design to create a smaller diameter handle.

Victor was the first to design and invent the cutting attachment which included spiral mixers.

**1940s**

The SR 40 Oxygen Safety Regulator was a single stage reduction regulator. It featured a simplified seat mechanism which eliminated the ball housing.

**1937**

Mayor Angelo Rossi uses a Victor cutting torch to cut the chain opening the Golden Gate Bridge.



VICTOR

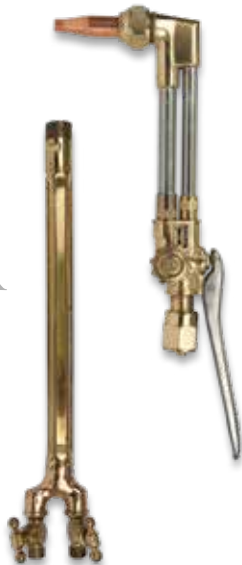

# EVOLUTION. INNOVATION. INSPIRATION.

**1980**

Victor began to manufacture the 315 welding handle with built-in check valves.



**1995**

Victor patents built-in flashback arrestors into their torches for added operator safety.



**2013**

Victor 400 series cutting torches with ergonomic handle and G Series regulators released.



**1966**

Victor Equipment Company moved to Denton, Texas.



**2009**

Victor introduced the EDGE™ regulator changing the landscape of gas regulation.



Victor manufacturing team worked overtime to produce over 5,000 pieces of equipment including special 15 and 20 foot length cutting torches to help with 9/11 clean-up efforts.



**2012**

The Golden Gate Bridge has its 75th Anniversary, Governor Schwarzenegger uses a Victor torch to recreate the original chain cutting ceremony.

**2014**

Victor becomes An ESAB Brand



## Journeyman® EDGE 2.0

Cutting, Heating and Welding Outfit

- Cuts up to 8 in. (203.2 mm), welds up to 3 in. (76.2 mm) with accessories
- Up to 1,118,000 BTUs/hour heating
- ESS42 Series regulators
- WH 315FC+ torch handle with built-in flash arrestors and check valves
- CA 2460+ cutting attachment
- Also includes cutting tip, tip cleaner, heating nozzle, striker, goggles, hose, welding nozzles and two EDGE 2.0 regulators



## Journeyman® II EDGE 2.0

Cutting and Welding Outfit

- Cuts up to 8 in. (203.2 mm), welds up to 3 in. (76.2 mm) with accessories
- ESS42 Series regulators
- WH 315FC+ torch handle with built-in flash arrestors and check valves
- CA 2460+ cutting attachment
- Also includes cutting tip, tip cleaner, heating nozzle, striker, goggles, hose, welding nozzles and two EDGE 2.0 regulators



### Ordering Information

Journeyman EDGE 2.0 540/300, 90° Plus Outfit	0384-2100
Journeyman EDGE 2.0 540/510, 90° Plus Outfit	0384-2101

### Ordering Information

Journeyman II EDGE 2.0 540/300, 90° Plus Outfit	0384-2110
Journeyman II EDGE 2.0 540/510, 90° Plus Outfit	0384-2111
Journeyman II AF EDGE 2.0 540/510LP, 90° Plus Outfit (propane)	0384-2112
Journeyman II AF EDGE 2.0 540/510LP, 90° Plus Outfit (propylene)	0384-2113

## Contender® EDGE 2.0

Cutting, Heating and Welding Outfit

- Cuts up to 8 in. (203.2 mm) and welds up to 3 in. (76.2 mm) with accessories
- ESS32 Series regulators
- WH 315FC+ torch handle with built-in flash arrestors and check valves
- CA 2460+ cutting attachment
- Also includes cutting tip, tip cleaner, striker, goggles, hose, welding nozzle, heating nozzle and two EDGE 2.0 regulators



## Performer® EDGE 2.0

Cutting, Heating and Welding Outfit

- Cuts up to 6 in. (152.4 mm) and welds up to 1/4 in. (6.4 mm) with accessories
- ESS32 Series regulators
- CA1350 cutting attachment
- WH100FC torch handle with built-in flashback arrestors and check valves
- Also includes cutting tip, tip cleaner, striker, goggles, hose, welding nozzle, heating nozzle and two EDGE 2.0 regulators



### Ordering Information

Contender 540/510 EDGE 2.0 Outfit	0384-2130
Contender 540/300 EDGE 2.0 Outfit	0384-2131
Contender AF 540/510LP EDGE 2.0 Outfit (propane & propylene tips)	0384-2132

### Ordering Information

Performer 540/510 EDGE 2.0 Outfit	0384-2125
Performer 540/300 EDGE 2.0 Outfit	0384-2126
Performer AF 540/510LP EDGE 2.0 Outfit (propane & propylene tips)	0384-2127
Journeyman II AF EDGE 2.0 540/510LP, 90° Plus Outfit (propylene)	0384-2113

## Medalist® 350

### Heavy-Duty Cutting and Welding Outfit

- Cuts up to 3/4in. (19.1 mm) or 6 in. (152.4 mm) with optional tips
- Welds up to 1/8 in. (3.2 mm) or 3in. (76.2 mm) with optional nozzles
- Heavy-duty construction
- G350 Series regulators
- WH411C torch handle with built-in check valves
- CA411-1 cutting attachment
- Also includes welding nozzle, cutting tip, RM-grade hose 25 ft. x 1/4in. (7.6 m x 6.4 mm), striker and soft-sided goggles



## Medalist® 250

### Medium-Duty Cutting and Welding Outfit

- Cuts up to 1/2 in. (12.7 mm) or 5 in. (127.0 mm) with optional tips
- Welds up to 5/64 in. (2.0 mm) or 1.25 in. (31.8 mm) with optional nozzles
- Medium duty construction
- G250 Series regulators
- WH411C torch handle with built-in check valves
- CA411-3 cutting attachment
- Also includes welding nozzle, cutting tip, RM-grade hose 25 ft. x 1/4in. (7.6 m x 6.4 mm), striker and soft-sided goggles



#### Ordering Information

Medalist 350 G350-540/300	0384-2691
Medalist 350 G350-540/510 Medalist 250	0384-2690
Medalist 350G350AF-510LP Propane/NG	0384-2692

#### Ordering Information

Medalist 250 G250-540/510	0384-2540
Medalist 250 G250-540/300	0384-2541
Medalist 250 G250AF-540/510LP Propane/NG	0384-2544
Medalist 250 G250AF-540/510LP Propylene	0384-2545

## Journeyman® Select EDGE 2.0

### Heavy-Duty Cutting Outfit

- Cuts up to 8 in. (203.2 mm) with optional tips
- WH 315FC torch handle with built-in flashback arrestors and check valves
- ESS42 Series regulators
- WH 315FC+ torch handle with built-in flash arrestors and check valves
- CA 2460+ cutting attachment



## Cutter™ Select ST2600FC EDGE 2.0

### Heavy-Duty Cutting Outfit

- Cuts up to 8 in. (203.2 mm) with accessories
- ST 2600FC cutting torch with built-in flashback arrestors and check valves
- ESS42 Series regulators
- Available with 90° head angle



#### Ordering Information

Journeyman Select EDGE 2.0 540/510, 90° Plus Outfit	0384-2081
Journeyman Select EDGE 2.0 540/510, 75° Plus Outfit	0384-2082
Journeyman Select EDGE 2.0 540/300, 90° Plus Outfit	0384-2083
Journeyman Select AF EDGE 2.0 540/510LP, 90° Plus Outfit	0384-2088

#### Ordering Information

Cutter EDGE 2.0 ST2600FC 540/510, 90° Outfit	0384-2120
Cutter EDGE 2.0 ST2600FC 540/300, 90° Outfit	0384-2121
Cutter AF EDGE 2.0 ST2600FC 540/510LP, 90° Outfit	0384-2122

### Cutter™ Select ST1000FC Heavy-Duty Cutting Outfit

- Cuts up to 5 in. (127 mm) with accessories
- Regulator for acetylene
- Cutting torch will operate on any fuel gas with proper tip
- Capable cutting from 1/8 in. (3 mm) up to 5 in. (127mm) with appropriate cutting tip
- CSR 350 Series Regulator
- ST1000FC 21" 90 degree Torch



Ordering Information	
Cutter Select ST1000FC w/ CGA 510 outfit	0384-0859
Cutter Select ST1000FC w/CGA 300 outfit	0384-0860

### Cutter™ Select ST900FC EDGE 2.0 Heavy-Duty Cutting Outfit

- Cuts up to 8 in. (203.2 mm) and welding up to 1/4 in. (6.4 mm) with accessories
- ESS32 Series regulators
- ST900FC Straight Cutting Torch with built-in flashback arrestors



Ordering Information	
Cutter 540/300 ST900FC EDGE 2.0 Outfit	0384-2140
Cutter 540/510 ST900FC EDGE 2.0 Outfit	0384-2141
Cutter AF 540/510LP ST900FC EDGE 2.0 Outfit	0384-2142

### Portable Tote Kit - 100FC Torch Handle/CA 1350 Cutting Attachment Medium-Duty Portable Outfit

- Cuts up to 1/2 in. (12.7 mm) or 4 in. (101.6 mm) with optional tips
- Welds up to 1/4 in. (6.4 mm) or 1.25 in. (31.8 mm) with optional nozzles
- CSR 150 Series regulators
- 100FC torch handle with built-in flashback arrestors and check valves
- CA 1350 cutting attachment
- Welding nozzle
- Also includes cutting tip, T-grade hose 10' x 3/16" (3.1 m x 4.8 mm), striker and goggles



**Optional**

- 10 cu ft CGA 200 acetylene cylinder
- 20 cu ft CGA 540 oxygen cylinder

Ordering Information	
Tote - Medium Duty Portable Outfit 100FC Torch Handle, CA 1350 Cutting Attachment, 540/MC CSR 150 R	0384-0935
Tote - Medium Duty Portable Outfit 100FC Torch Handle, CA 1350 Cutting Attachment, 540/MC CSR 150 R	0384-0936

### Portable Tote Kit - W 270FC-V Torch Handle/CA 270-V Cutting Attachment Medium-Duty Portable Outfit

- Rugged patented design with a molded plastic carrying case
- Cuts up to 1.25 in. (31.8 mm) or welds up to 3/32 in. (2.4 mm)
- D 150 CR regulator
- D 160 AR regulator
- WH 270FC-V welding torch with built-in flashback arrestors and check valves
- CA 270-V cutting attachment
- Also includes welding nozzle, cutting tip, Twin RM-grade hose 12.5 ft. x 3/16 in. (3.81 m x 4.8 mm)



**Optional**

- 10 cu ft CGA 200 acetylene cylinder
- 20 cu ft CGA 540 oxygen cylinder

Ordering Information	
Tote - Medium Duty Portable Outfit, WH 270FC-V Torch Handle, CA 270-V Cutting Attachment, 540/200 FP	0384-0938
Tote - Medium Duty Portable Outfit, WH 270FC-V Torch Handle, CA 270-V Cutting Attachment, 540/200 FP	0384-0939



## G150 Portable Tote Light-Duty Portable Outfit

- Designed with a patented, molded, plastic carrying case
- Ergonomic handle
- Patented balance design with small footprint
- Built-in storage compartments
- Includes G-150 regulators



## Fire-Stick Torch Kit Torch Kit

- This heating system can deliver up to 500,000 btu's avg./hr.
- Two models available – with or without regulator
- For propane – (hose approved for LP)



GAS OUTFITS

Ordering Information	
G150-100-CP Tote w/o tanks	0384-0943
G150-100-CPT Tote w/ tanks	0384-0944
G150-J-P Tote w/o tanks	0384-0945
G150-J-PT Tote w/ tanks	0384-0946
G150-J-CP Tote w/o tanks	0384-0947
G150-J-CPT Tote w/ tanks	0384-0948
G150-J-AFP Tote w/o tanks	0384-0954
G150-J-AP Tote w/o tanks	0384-0955
G150-J-APT Tote w/ tanks	0384-0956
G150-J-ACP Tote w/o tanks	0384-0957
G150-J-ACPT Tote w/ tanks	0384-0958

Ordering Information	
HT-500 Torch Kit, Fire-Stick, 500,000 BTU's	0384-1261
HS 101 Torch Kit, Fire-Stick, 350,000 BTU's	0384-1251

## Powder Spray Torch Kit Medium-Duty Torch Kit

- The Victor VPT-100 provides powder feed into the gas mixture
- Deposit thickness is controlled by the powder flow rate of the torch
- 100 FC Torch Handle
- TE tips: size 3, 4
- TEMF tip: size 6
- 1 lb of Tungsten Carbide #600
- 1 lb of Nickel base #22
- Elbow assembly
- Hopper assembly



Ordering Information	
VPT-100 Kit, 100FC Torch Handle, VPT Powder Torch, (3) Tips	0384-1265

## Model Numbering Explanation

Single or Two Stage model designations as well as those identifying delivery range are common to all regulators unless otherwise noted on individual ordering charts. When ordering be certain to specify delivery range, CGA inlet connections, and regulator part number.

### Regulator Ordering Matrix

XX  
↓

XXX  
↓

X  
↓

XXX  
↓

Single Stage Model		Series		Delivery Range		CGA Connection*			
SR	Single Stage	150	Light Duty	A	2-15 psig	CGA 200	Acetylene (MC)	CGA 580	Nitrogen, Argon, Helium
HSR	Single Stage with Flow Meter	250	Medium Duty	B	2-40 psig	CGA 300	Acetylene (Commercial)	CGA 590	Air (Industrial)
VTS	Two Stage Design	350	Heavy Duty	C	4-80 psig	CGA 320	Carbon Dioxide	CGA 660	Corrosive
HVTS	Two Stage with Flow Meter	450	Extra Heavy Duty	D	5-125 psig	CGA 326	Nitrous Oxide	CGA 677	Nitrogen, Argon & Helium
AR	Air Relieving			E	10-200 psig	CGA 346	Air (Formerly 1340)	CGA 680	Nitrogen, Argon
S	Station			F	50-750 psig	CGA 347	Air	CGA 701	Oxygen
L	Line			G	100-1500 psig	CGA 350	Fuel Gas, Hydrogen	CGA 992	British Oxygen & Inert Gas
HRF	Single Stage w/ Internal Flow Meter			J	200-3000 psig	CGA 500	Medical Mixtures	CGA 993	British Fuel Gas
AF	Argon Flow Gauge			K	300-4500 psig	CGA 510	Acetylene (POL)	CGA 996	Manifold Oxygen & Inert Gas
CF	CO2 Flow Gauge					CGA 510LP	Propane, Natural Gas, Propylene	CGA 997	Manifold Fuel Gas
DL	Dome Loaded					CGA 520	Acetylene (B)	CGA 024	Station Oxygen
BSL	Bulk System Line					CGA 540	Oxygen	CGA 025	Station Fuel Gas
DFM	Dual Flow Meter					CGA 555	Propane, Butane	CGA 034	Station Inert Gas
						CGA 577	Oxygen		

**Ordering Example: SR-250-D-540**

Single Stage, 250 Series, with 5-125 Delivery Range, for Oxygen Service CGA 540 Inlet

### Edge Series Regulator Ordering Matrix

X  
↓

XX  
↓

X  
↓

XXX  
↓

XXX  
↓

XX  
↓

Series	Type	Capacity	Max Delivery Pressure	CGA Connection*	Suffix		
E	EDGE Series	SS	Single Stage, Side Inlet	7	High Flow	R	Rear Entry
		LC	Liquid Cylinder	4	High Capacity	A	Acetylene
		ST	Station	3	Medium Capacity	F	Fuel Gas
		SL	Line			X	Oxygen
		TS	Two Stage			LP	Liquified Petroleum

15, 40, 80, 125, 200, 750, 1500, 3000, 4500

\*Same as above Chart

**Ordering Example: ESS4-125-510LP**

Edge Series Single Stage, High Capacity w/ up to 125 Delivery Range, for Liquid Petroleum Service CGA 510 Inlet

### Regulator Delivery Ranges

A	2-15 psig	F	50-750 psig
B	2-40 psig	G	100-1500 psig
C	4-80 psig	J	200-3000 psig
D	5-125 psig	K	300-4500 psig
E	10-200 psig		

Outlet pressure delivery ranges are not minimum or maximum outlet pressure limits. Regulators can be adjusted to zero psig outlet pressure and generally, to pressures in excess of those specified. The use of these regulators to control pressures outside of the specified ranges is not recommended.

### Regulator Gauges

A Range	2-30 psig	F Range	50-1000 psig
B Range	2-60 psig	G Range	100-2000 psig
C Range	4-100 psig	J Range	200-4000 psig
D Range	5-200 psig	K Range	200-6000 psig
E Range	10-400 psig		

When ordering regulators, specify part numbers. Regulators should not be used as a shut-off valve nor should they be used to protect downstream equipment. Unless otherwise noted, high pressure gauges for all oxygen, inert gas, CO<sub>2</sub> and N<sub>2</sub>O, and hydrogen models are graduated 200-4000 psig. High pressure gauges for fuel gas models are graduated 10-400 psig. Low pressure or outlet gauge ranges are determined by the regulator delivery range selected.

## How to read the Flow Data Charts:

The regulator flow data is provided to assist in determining the proper regulator for the required application. The data is given for reference purposes only. If additional information is necessary contact your local distributor or the Customer Service Department at 1-800-426-1888

The regulator flow data was established by connecting a valve to the regulator outlet. The valve was opened and the flow rates measured. The amount of pressure drop is shown on the curves as the flow increases.

### Example

An SR 450D with an inlet of 2000 psig and an internal pressure setting of 125 psig (no flow) will flow 1000 SCFH, but the delivery pressure will drop to 115 lb As the flow increased to 2000 SCFH, the pressure will drop to 108 psig.

With an inlet pressure of 200 psig and an initial setting of 125 psig, the regulator will flow 1000 SCFH with a pressure drop to 98 psig. At 2000 SCFH flow, the pressure will drop to 78 psig. If a delivery pressure other than the ones shown on the flow charts is required, use an average curve rate between the upper and lower pressures shown.

Flow (SCFH)

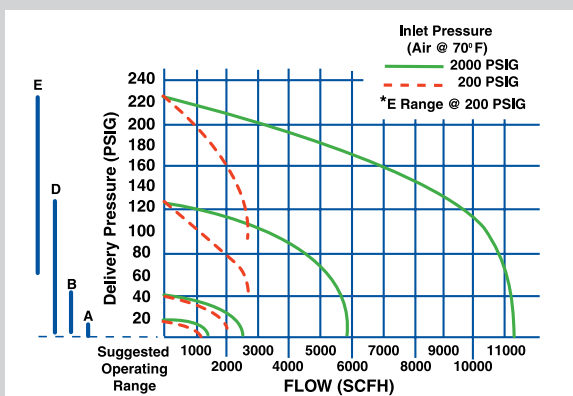

### Delivery Pressure Rise

Single stage regulators have an increase in delivery pressure as the cylinder pressure decreases. Listed below is the amount of pressure increase per 100 psig decrease in cylinder (inlet) pressure.

ESS7-125	.95 psig
ESS7-200	1.54 psig
ESS4-125-540	.59 psig
ESS3-125-540	.53 psig
SR 4 Series	J & K Range 4.8 psig
SR 5 Series	1.0 psig
SR 250 Series	0.5 psig
SR 350 Series	0.8 psig
SR 450 Series	0.6 psig
SR 600 Series	0.58 psig
SR 700 Series	1.2 psig

The change in delivery pressure of a Two Stage regulator from full to empty Cylinder (inlet pressure) is negligible.

### For Conversion to Other Gases

All flow capacity information is given in SCFH of free air (1.00). For conversion to other gases multiply the air flow by the correction factor listed below.

■ Acetylene.....	1.05
■ Argon.....	0.85
■ Carbon Dioxide.....	0.81
■ Helium.....	2.69
■ Hydrogen.....	3.79
■ Mapp®.....	0.82
■ Natural Gas.....	1.28
■ Nitrogen.....	1.02
■ Oxygen.....	0.95
■ Propane.....	0.80

**Pressure Drop Reference Charts**

**Oxygen Hose**

Delivery Pressure Pounds Per Square Inch	Oxygen Flow SCFH	Pressure Drop Pound Per Square Inch															
		Hose Length in Feet															
		3/16" Hose				1/4" Hose				5/16" Hose				3/8" Hose			
		12.5	25	50	100	12.5	25	50	100	12.5	25	50	100	12.5	25	50	100
10	100	5.0	6.3				2.0	3.8	6.0	*	*	*	2.3	*	*	*	2.0
	250					9.4				2.7	4.1	5.9		*	*	3.3	6.4
25	100	3.6	5.7	8.2	13.4	*	*	2.9	4.3	*	*	*	*	*	*	*	*
	250	13.2	18.3			6.3	7.9	11.7	16.8	*	2.4	3.2	6.7	*	*	*	3.7
50	500					21.5				6.3	8.7	12.1	19.9	2.7	4.6	6.9	11.9
	100	2.0	3.4	5.9	9.3	*	*	2.0	2.7	*	*	*	*	*	*	*	*
	250	8.0	12.6	19.4		2.7	5.0	7.9	11.0	*	*	2.2	3.9	*	*	*	2.6
	500					14.1	18.2			3.4	5.9	7.7	13.3	*	2.9	4.7	8.0
75	100	*	2.6	3.8	7.1	*	*	*	2.8	*	*	*	*	*	*	*	*
	250	6.0	9.4	13.3	23.1	3.0	3.8	6.0	8.2	*	*	*	2.8	*	*	*	2.0
	500	19.7				10.7	13.8	19.8		2.5	3.9	6.3	9.4		2.0	3.4	5.9
	750					22.5				6.6	8.8	13.7	18.8	2.7	4.1	7.0	12.2
1000	1000									11.8	14.7	22.6		4.9	6.9	12.0	20.3
	100	*	*	2.7	4	*	*	*	*	*	*	*	*	*	*	*	*
	250	4.7	6.7	10.3	16.9	2.2	2.8	4.3	6.0	*	*	*	2.2	*	*	*	*
	500	14.1	21.0			8.1	10.8	15.0	21.2	2.0	2.9	4.4	7.1	*	*	2.1	4.6
	750					17.7	23.0	32.3	42.8	4.7	6.9	10.3	15.4	*	2.9	4.9	8.7
	1000					31.0	37.0	53.0	68.5	8.6	11.8	17.4		3.1	5.2	8.8	14.4
	1500					65.5	82.0			19.1				7.7	11.8	19.4	

GAS CONTROL

**Acetylene Hose**

Delivery Pressure Pounds Per Square Inch	Acetylene Flow SCFH	Pressure Drop Pound Per Square Inch															
		Hose Length in Feet															
		3/16" Hose				1/4" Hose				5/16" Hose				3/8" Hose			
		12.5	25	50	100	12.5	25	50	100	12.5	25	50	100	12.5	25	50	100
5	25	0.3	0.5	1.0	1.8	**	**	0.5	0.8	**	**	**	0.3	**	**	**	**
	50	1.2	2.0	3.2		0.5	0.9	1.3	2.4	**	0.3	0.4	0.7	**	**	0.3	0.4
	75	2.6	3.9			1.2	1.8	2.6	4.5	0.4	0.5	0.8	1.4	**	0.3	0.5	0.8
	100	4.3				1.9	2.8	4.4		0.5	0.8	1.3	2.4	0.3	0.4	0.7	1.1
	150					4.0				1.2	1.7	2.7	4.8	0.5	0.8	1.2	2.2
10	25	0.3	0.5	0.8	1.4	**	**	0.3	0.7	**	**	**	**	**	**	**	**
	50	0.9	1.6	2.5	4.9	0.5	0.7	1.1	2.0	**	**	0.3	0.6	**	**	**	0.3
	75	2.0	3.1	6.3		0.9	1.4	2.2	3.7	0.3	0.4	0.5	0.6	**	**	0.3	0.6
	100	4.5	5.4			1.6	2.0	3.6	6.0	0.4	0.6	0.9	2.2	**	0.3	0.5	1.9
	150	7.0				3.2	4.5	7.3		0.9	1.3	2.1	3.9	0.4	0.6	1.0	2.5
	250					8.1				2.3	3.5	5.2	9.8	0.9	1.4	2.5	4.4
14	500									8.2				3.3	4.8	8.3	
	25	**	0.4		1.3	**	**	0.3	0.6	**	**	**	**	**	**	**	**
	50	0.8	1.4		4.6	0.4	0.6	0.9	1.6	**	**	**	0.4	**	**	**	0.3
	75	1.9	2.9		10.0	0.8	1.2	1.9	3.0	**	0.3	0.5	1.0	**	**	0.3	0.5
	100	3.5	5.1			1.4	2.0	3.0	4.7	0.3	0.6	0.7	1.7	**	0.3	0.4	0.8
	150	7.9				2.9	4.0	6.0	8.7	0.8	1.2	1.7	3.4	0.3	0.5	0.9	1.6
	250					7.4	9.5			2.0	3.1	4.5	8.1	0.7	1.2	2.3	3.8
	500								8.7	10.5	13.7		2.9	4.0	8.1	11.5	

\*Indicates pressure drop of less than 2.0 per sq. in.

\*\*Indicates pressure drop of less than 0.2 per sq. in.

To obtain the recommended inlet pressure at the equipment, add the pressure drop figure (shown above) to the delivery pressure at the regulator. Do not exceed 15 psig for acetylene.

## Regulator Selection Guide - By Gas Service

### Oxygen

Description	Model	Part Number	Delivery Range (psig)	Gauge Range Inlet	Gauge Range Outlet	CGA Inlet Connection	Outlet Connection	Max Inlet Pressure (psig)
ESS7 High Capacity Single Stage	ESS7-125-540	0781-5181	5-125	4000	200	540	7/8" – 14 M RH	3000
ESS7 High Capacity Single Stage	ESS7-200-540	0781-5183	10-200	4000	400	540	7/8" – 14 M RH	3000
ESS42 EDGE 2.0 High Capacity Single Stage	ESS42-60-540	0781-3600	2-60	4000	60	540	9/16" – 18 M RH	3000
ESS42 EDGE 2.0 High Capacity Single Stage	ESS42-150-540	0781-3601	5-150	4000	200	540	9/16" – 18 M RH	3000
ESS32 EDGE 2.0 Medium Capacity Single Stage	ESS32-60-540	0781-3627	0-60	4000	200	540	9/16" – 18 M RH	3000
ESS32 EDGE 2.0 Medium Capacity Single Stage	ESS32-150-540	0781-3626	0-150	4000	200	540	9/16" – 18 M RH	3000
SR 450 Heavy Duty Single Stage	SR-450D-540	0781-0527	5-125	4000	200	540	9/16" – 18 M RH	3000
SR 350 Heavy/Medium Single Stage	SR-350D-540	0781-2341	5-125	4000	200	540	9/16" – 18 M RH	3000
VTS 700 Extra Heavy Duty Two Stage	VTS700E-540	0780-0939	10-200	4000	400	540	9/16" – 18 M RH	3000
ETS4 High Capacity Two Stage	ETS4-40-540	0781-5217	2-40	4000	60	540	9/16" – 18 M RH	3000
ETS4 High Capacity Two Stage	ETS4-125-540	0781-5218	5-125	4000	200	540	9/16" – 18 M RH	3000
ETS4 High Capacity Two Stage	ETS4-200-540	0781-5219	10-200	4000	400	540	9/16" – 18 M RH	3000
VTS 250 Medium Duty Two Stage	VTS250A-540	0781-3503	2-15	4000	30	540	9/16" – 18 M RH	3000
VTS 250 Medium Duty Two Stage	VTS250B-540	0781-3504	2-40	4000	60	540	9/16" – 18 M RH	3000
VTS 250 Medium Duty Two Stage	VTS250C-540	0781-3505	4-80	4000	100	540	9/16" – 18 M RH	3000
VTS 250 Medium Duty Two Stage	VTS250D-540	0781-3506	5-125	4000	200	540	9/16" – 18 M RH	3000
SR 4 High Pressure	SR4F-540	0781-1405	30-750	4000	1000	540	1/4" Swaglok®	3000
SR 4 High Pressure	SR4G-540	0781-1425	100-1500	4000	2000	540	1/4" Swaglok®	3000
SR 4 High Pressure	SR4J-540	0781-1445	200-3000	4000	4000	540	1/4" Swaglok®	3000
SR 600 High Pressure	SR600-550-540	0781-1610	5-550	6000	1000	540	1/4" Swaglok®	3000
ELC4 High Capacity Liquid Cylinder	ELC4-125-540R	0781-5199	5-125	--	200	540	9/16" – 18 M RH	3000
ESL4 High Capacity Line	ESL4-125-250	0781-5190	5-125	--	200	1/4" NPT	1/4" NPT F	3000
EST4 High Capacity Station	EST4-40-024	0781-5191	2-40	--	60	024	9/16" – 18 M RH	200
EST4 High Capacity Station	EST4-40-024R	0781-5204	2-40	--	60	024	9/16" – 18 M RH	200
EST4 High Capacity Station	EST4-80-024	0781-5192	4-80	--	100	024	9/16" – 18 M RH	200
EST4 High Capacity Station	EST4-80-024R	0781-5205	4-80	--	100	024	9/16" – 18 M RH	200
EST4 High Capacity Station	EST4-125-024	0781-5193	5-125	--	200	024	9/16" – 18 M RH	200
EST4 High Capacity Station	EST4-125-024R	0781-5206	5-125	--	200	024	9/16" – 18 M RH	200
L700 High Flow Line	L700C-500	0780-1229	4-80	--	100	1/2" NPT F	1/2" NPT F	350
L700 High Flow Line	L700C-750	0780-1220	4-80	--	100	3/4" NPT F	3/4" NPT F	350
L700 High Flow Line	L700D-500	0780-1207	5-125	--	200	1/2" NPT F	1/2" NPT F	350
L700 High Flow Line	L700D-500PMT	0780-1236	5-125	--	200	1/2" NPT F	1/2" NPT F	350
L700 High Flow Line	L700D-750	0780-1209	5-125	--	200	3/4" NPT F	3/4" NPT F	350
L700 High Flow Line	L700E-500	0780-1221	10-200	--	400	1/2" NPT F	1/2" NPT F	350
L700 High Flow Line	L700E-750	0780-1222	10-200	--	400	3/4" NPT F	3/4" NPT F	350
DL700 Dome Load	DL700	0780-1188	5-125	--	--	1/2" NPT F	1/2" NPT F	500
BSL Bulk System Line	BSL700	0780-1200	10-200	--	400	1/2" NPT F	1/2" NPT F	350

## Regulator Selection Guide - By Gas Service

### Acetylene

Description	Model	Part Number	Delivery Range (psig)	Gauge Range Inlet	Gauge Range Outlet	CGA Inlet Connection	Outlet Connection	Max Inlet Pressure (psig)
ESS7 High Capacity Single Stage	ESS7-15-510	0781-5187	2-15	400	30	510	7/8" – 14 LH	3000
ESS7 High Capacity Single Stage	ESS7-200-350	0781-5186	10-200	4000	400	350	7/8" – 14 M LH	3000
ESS42 EDGE 2.0 High Capacity Single Stage	ESS42-15-510	0781-3602	2-15	400	30	510	9/16" – 18 M LH	3000
ESS42 EDGE 2.0 High Capacity Single Stage	ESS42-15-300	0781-3603	2-15	400	30	300	9/16" – 18 M LH	3000
ESS42 EDGE 2.0 High Capacity Single Stage	ESS42-15-993	0781-3604	2-15	400	30	993	9/16" – 18 M LH	3000
ESS42 EDGE 2.0 High Capacity Single Stage	ESS42-15-410	0781-3605	2-15	400	30	410	9/16" – 18 M LH	3000
ESS32 EDGE 2.0 Medium Capacity Single Stage	ESS32-15-510	0781-3628	0-15	400	30	510	9/16" – 18 M LH	3000
ESS32 EDGE 2.0 Medium Capacity Single Stage	ESS32-15-300	0781-3629	0-15	400	30	300	9/16" – 18 M LH	3000
SR 450 Heavy Duty Single Stage	SR460A-300	0781-0583	2-15	400	30	300	9/16" – 18 M LH	3000
SR 450 Heavy Duty Single Stage	SR460A-510	0781-0584	2-15	400	30	510	9/16" – 18 M LH	3000
SR 350 Heavy/Medium Single Stage	SR360A-300	0781-2400	2-15	400	30	300	9/16" – 18 M LH	3000
SR 350 Heavy/Medium Single Stage	SR360A-510	0781-2401	2-15	400	30	510	9/16" – 18 M LH	3000
SR 250 Medium Duty Single Stage	SR260A-300	0781-0085	2-15	400	30	300	9/16" – 18 M LH	3000
SR 250 Medium Duty Single Stage	SR260A-510	0781-0087	2-15	400	30	510	9/16" – 18 M LH	3000
VTS 700 Extra Heavy Duty Two Stage	VTS710A-510	0780-0984	2-15	400	30	510	7/8" – 14 M LH	3000
ETS4 High Capacity Two Stage	ETS4-15-300	0781-5229	2-15	400	30	300	9/16" – 18 M LH	3000
ETS4 High Capacity Two Stage	ETS4-15-510	0781-5230	2-15	400	30	510	9/16" – 18 M LH	3000
ETS4 High Capacity Two Stage	ETS4-15-993	07815-2122	2-15	400	30	993	9/16" – 18 M LH	3000
VTS 250 Medium Duty Two Stage	VTS260A-300	0781-3583	2-15	400	30	300	9/16" – 18 M LH	3000
VTS 250 Medium Duty Two Stage	VTS260A-510	0781-3484	2-15	400	30	300	9/16" – 18 M LH	3000
ESL4 High Capacity Line	ESL4-15-250A	0781-5208	2-15	--	30	1/4" NPT F	1/4" NPT F	350
EST4 High Capacity Station	EST4-15-025	0781-5194	2-15	--	30	025	9/16" – 18 M LH	200
EST4 High Capacity Station	EST4-15-025R	0781-5209	2-15	--	30	025	9/16" – 18 M LH	200
L700 High Flow Line	L710A-500	0780-1233	2-15	--	30	1/2" NPT F	1/2" NPT F	350
L700 High Flow Line	L710A-750	0780-1201	2-15	--	30	3/4" NPT F	3/4" NPT F	350

GAS CONTROL

### EDGE Series Color Coding by Gas Type



<b>YELLOW</b>	<b>RED</b>	<b>GREEN</b>	<b>BLACK</b>	<b>GRAY</b>	<b>ORANGE</b>
<b>Air</b>	<b>Acetylene</b>	<b>Oxygen</b>	<b>Inert Gas</b>	<b>Carbon Dioxide</b>	<b>LPG</b>

## Regulator Selection Guide - By Gas Service

### Air

Description	Model	Part Number	Delivery Range (psig)	Gauge Range Inlet	Gauge Range Outlet	CGA Inlet Connection	Outlet Connection	Max Inlet Pressure (psig)
ESS42 EDGE 2.0 High Capacity Single Stage	ESS42-150-346	0781-3613	5-150	4000	200	346	5/8" – 18 F LH	3000
ESS42 EDGE 2.0 High Capacity Single Stage	ESS42-150-590	0781-3614	5-150	4000	400	590	5/8" – 18 F LH	3000
ESS32 EDGE 2.0 Medium Capacity Single Stage	ESS32-150-346	0781-3637	0-150	4000	200	346	5/8" – 18 F LH	3000
SR 450 Heavy Duty Single Stage	SR450D-346	0781-0532	5-125	4000	200	346	5/8" – 18 F LH	3000
ETS4 High Capacity Two Stage	ETS4-125-346	0781-5231	5-125	4000	200	346	5/8" – 18 F LH	3000
ETS4 High Capacity Two Stage	ETS4-200-346	0781-5232	10-200	4000	400	346	5/8" – 18 F LH	3000
ETS4 High Capacity Two Stage	ETS4-125-590	0781-5224	5-125	4000	200	346	5/8" – 18 F LH	3000
VTS 250 Medium Duty Two Stage	VTS250C-346	0781-3510	4-80	4000	100	346	5/8" – 18 F LH	3000
VTS 250 Medium Duty Two Stage	VTS250D-346	0781-3512	5-125	4000	200	346	5/8" – 18 F LH	3000
SR 4 High Pressure	SR4F-347	0781-1403	50-750	6000	1000	347	1/4" Swagelok®	5500
SR 4 High Pressure	SR4G-346	0781-1422	100-1500	4000	2000	346	1/4" Swagelok	3000
SR 4 High Pressure	SR4J-346	0781-1442	200-3000	4000	4000	346	1/4" Swagelok	3000
SR 4 High Pressure	SR4K-347	0781-1463	300-4500	6000	6000	347	1/4" Swagelok	5500
SR 600 High Pressure	SR600-350-347	0781-1605	5-350	6000	600	347	1/4" Swagelok	5500
ESL4 High Capacity Line	ELS4-125-250	0781-5190	5-125	--	200	1/4" NPT F	1/4" NPT F	3000
L700 High Flow Line	L700C-500	0780-1229	4-80	--	100	1/2" NPT F	1/2" NPT F	350
L700 High Flow Line	L700C-750	0780-1220	4-80	--	100	3/4" NPT F	3/4" NPT F	350
L700 High Flow Line	L700D-500	0780-1207	5-125	--	200	1/2" NPT F	1/2" NPT F	350
L700 High Flow Line	L700D-500PMT	0780-1236	5-125	--	200	1/2" NPT F	1/2" NPT F	350
L700 High Flow Line	L700D-750	0780-1209	5-125	--	200	3/4" NPT F	3/4" NPT F	350
L700 High Flow Line	L700E-500	0780-1221	10-200	--	400	1/2" NPT F	1/2" NPT F	350
L700 High Flow Line	L700E-750	0780-1222	10-200	--	400	3/4" NPT F	3/4" NPT F	350
DL700 Dome Load	DL700	0780-1188	5-125	--	--	1/2" NPT F	1/2" NPT F	500

## Regulator Selection Guide - By Gas Service

### Inert Gas - Nitrogen, Argon, Helium

Description	Model	Part Number	Delivery Range (psig)	Gauge Range Inlet	Gauge Range Outlet	CGA Inlet Connection	Outlet Connection	Max Inlet Pressure (psig)
ESS7 High Capacity Single Stage	ESS7-125-580	0781-5182	5-125	4000	200	580	7/8" – 14 M RH	3000
ESS7 High Capacity Single Stage	ESS7-200-580	0781-5185	10-200	4000	400	580	7/8" – 14 M RH	3000
ESS42 EDGE 2.0 High Capacity Single Stage	ESS42-150-580	0781-3609	5-150	4000	200	580	5/8" – 15 F RH	3000
ESS32 EDGE 2.0 Medium Capacity Single Stage	ESS32-60-580	0781-3633	0-60	4000	60	580	5/8" – 15 F RH	3000
ESS32 EDGE 2.0 Medium Capacity Single Stage	ESS32-150-580	0781-3634	0-150	4000	200	580	5/8" – 15 F RH	3000
SR 450 Heavy Duty Single Stage	SR450D-580	0781-0528	5-125	4000	200	580	5/8" – 18 F RH	3000
SR 450 Heavy Duty Single Stage	SR450E-580	0781-0543	10-200	4000	400	580	5/8" – 18 F RH	3000
VTS Extra Heavy Duty Two Stage	VTS700D-580	0780-0928	5-125	4000	200	580	7/8" – 14 M RH	3000
VTS Extra Heavy Duty Two Stage	VTS700E-580	0780-0943	10-200	4000	400	580	7/8" – 14 M RH	3000
ETS4 High Capacity Two Stage	ETS4-40-580	0781-5221	2-40	4000	60	580	5/8" – 18 F RH	3000
ETS4 High Capacity Two Stage	ETS4-125-580	0781-5222	5-125	4000	200	580	5/8" – 18 F RH	3000
ETS4 High Capacity Two Stage	ETS4-200-580	0781-5223	10-200	4000	400	580	5/8" – 18 F RH	3000
VTS 250 Medium Duty Two Stage	VTS250A-580	0781-3507	2-15	4000	30	580	5/8" – 18 F RH	3000
VTS 250 Medium Duty Two Stage	VTS250B-580	0781-3508	2-40	4000	60	580	5/8" – 18 F RH	3000
VTS 250 Medium Duty Two Stage	VTS250C-580	0781-3509	4-80	4000	100	580	5/8" – 18 F RH	3000
VTS 250 Medium Duty Two Stage	VTS250D-580	0781-3513	5-125	4000	200	580	5/8" – 18 F RH	3000
SR 4 High Pressure	SR4F-580	0781-1408	50-750	4000	1000	580	1/4" Swagelok®	3000
SR 4 High Pressure	SR4F-680	0781-1410	50-750	6000	1000	680	1/4" Swagelok	5500
SR 4 High Pressure	SR4G-580	0781-1428	100-1500	4000	2000	580	1/4" Swagelok	3000
SR 4 High Pressure	SR4G-680	0781-1430	100-1500	6000	2000	680	1/4" Swagelok	5500
SR 4 High Pressure	SR4J-580	0781-1448	200-3000	4000	4000	580	1/4" Swagelok	3000
SR 4 High Pressure	SR4J-680	0781-1450	200-3000	6000	4000	680	1/4" Swagelok	5500
SR 4 High Pressure	SR4J-677	0781-1453	200-3000	7500	4000	677	1/4" Swagelok	7500
SR 4 High Pressure	SR4K-680	0781-1470	300-4500	6000	6000	680	1/4" Swagelok	5500
SR 4 High Pressure	SR4K-677	0781-1473	300-4500	7500	6000	677	1/4" Swagelok	7500
SR 600 High Pressure	SR600-350-580	0781-1601	5-350	6000	600	580	1/4" Swagelok	5500
SR 600 High Pressure	SR600-350-680	0781-1604	5-350	6000	600	680	1/4" Swagelok	5500
SR 600 High Pressure	SR600-550-580	0781-1611	5-550	6000	1000	580	1/4" Swagelok	3000
ELC4 High Capacity Liquid Cylinder	ELC4-125-580R	0781-5200	5-125	–	200	580	CGA 032 5/8" – 18 UNF	3000
ELC4 High Capacity Liquid Cylinder	ELC4-325-580R	0781-5202	5-325	–	400	580	CGA 032 5/8" – 18 UNF	3000
EST4 High Capacity Station	EST4-125-034	0781-5189	5-125	–	200	034	CGA 032 5/8" – 18 UNF	200
EST4 High Capacity Station	EST4-125-034R	0781-5207	5-125	–	200	034	CGA 032 5/8" – 18 UNF	200
L700 High Flow Line	L700C-500	0780-1229	4-80	–	100	1/2" NPT F	1/2" NPT F	350
L700 High Flow Line	L700C-750	0780-1220	4-80	–	100	3/4" NPT F	3/4" NPT F	350
L700 High Flow Line	L700D-500	0780-1207	5-125	–	200	1/2" NPT F	1/2" NPT F	350
L700 High Flow Line	L700D-500PMT	0780-1236	5-125	–	200	1/2" NPT F	1/2" NPT F	350
L700 High Flow Line	L700D-750	0780-1209		–	200	3/4" NPT F	3/4" NPT F	350
L700 High Flow Line	L700E-500	0780-1221	10-200	–	400	1/2" NPT F	1/2" NPT F	350
L700 High Flow Line	L700E-750	0780-1222	10-200	–	400	3/4" NPT F	3/4" NPT F	350
DL700 Dome Load	DL700	0780-1188	5-125	–	–	1/2" NPT F	1/2" NPT F	500
BSL Bulk System Line	BSL700	0780-1200	10-200	–	–	1/2" NPT F	1/2" NPT F	350



## Regulator Selection Guide - By Gas Service

### Inert Gas - Nitrogen, Argon, Helium (continued)

Description	Model	Part Number	Delivery Range (psig)	Gauge Range Inlet	Gauge Range Outlet	CGA Inlet Connection	Outlet Connection	Max Inlet Pressure (psig)
ESS3-FG Flow Gauge	ESS3-FG-580	0781-5120	0-40 psig	4000	50 CFH	580	CGA 032 5/8" - 18 UNF	3000
SLR 100 Surge Limiting Regulator	SLR100	0781-1197		--	--	030		200
FM150 Flow Meter Heavy Duty	FM150	1000-0268	10-60 Air* 10-30 Nit*	--	--	1/4" NPT M	5/8"-18 RH F	25
FM135 Flow Meter Heavy Duty	FM135	1000-0255	4-18 Argon* 10-50 Helium*	--	--	9/16"-18 RH F	5/8"-18 RH F	25
FM145 Flow Meter Heavy Duty	FM145	1000-0256	4-18 Argon* 10-50 Helium*	--	--	5/8" RH M	5/8"-18 RH F	25
FM155 Flow Meter Heavy Duty	FM155	1000-0257	4-18 Argon* 10-50 Helium*	--	--	5/8" NPT M	5/8"-18 RH F	25
FM137 Flow Meter Heavy Duty	FM137	1000-0261	15-65 Argon* 40-200 Helium*	--	--	9/16"-18 RH F	5/8"-18 RH F	25
FM147 Flow Meter Heavy Duty	FM147	1000-0262	15-70 Argon* 40-200 Helium*	--	--	5/8"-18 RH M	5/8"-18 RH F	25
FM157 Flow Meter Heavy Duty	FM157	1000-0263	15-65 Argon* 40-200 Helium*	--	--	1/4" NPT M	5/8"-18 RH F	25
FM370 Flow Meter Heavy Duty	FM370	1000-0258	5-50 Argon* 20-150 Helium*	--	--	9/16"-18 RH F	5/8"-18 RH F	25
FM371 Flow Meter Heavy Duty	FM371	1000-0259	5-50 Argon* 20-150 Helium*	--	--	5/8"-18 RH M	5/8"-18 RH F	25
FM372 Flow Meter Heavy Duty	FM372	1000-0182	5-50 Argon* 20-150 Helium*	--	--	1/4" NPT M	5/8"-18 RH F	25
HRF 2425 Medium Duty Flow Meter Regulator	HRF2425	0781-2731	10-50 Argon* 20-150 Helium*	--	--	580	5/8"-18 RH F	3000
HRF2480 Medium Duty Flow Meter Regulator	HRF2480	0781-2728	7.5-37.5 Argon*	--	--	580	5/8"-18 RH F	3000
DFM 150 Medium Duty Flow Meter Regulator	DFM150-580	0781-1153	5-50 Argon* 20-150 Helium*	--	--	580	5/8"-18 RH F	3000
HSR Medium Duty Flow Meter Regulator Single Stage	HSR2530	0781-3819	10-60 Nitrogen*	--	--	580	5/8"-18 RH F	3000
HSR Medium Duty Flow Meter Regulator Single Stage	HSR2535	0781-3867	4-18 Argon* 10-50 Helium*	--	--	580	5/8"-18 RH F	3000
HVTS Medium Duty Flow Meter Regulator Two Stage	HVTS2535	0781-3775	4-18 Argon* 10-50 Helium*	--	--	580	5/8"-18 RH F	3000
HSR Medium Duty Flow Meter Regulator Single Stage	HSR2537	0781-3871	15-65 Argon* 40-200 Helium*	--	--	580	5/8"-18 RH F	3000
HVTS Medium Duty Flow Meter Regulator Two Stage	HVTS2537	0781-3772	15-65 Argon* 40-200 Helium*	--	--	580	5/8"-18 RH F	3000
HSR Medium Duty Flow Meter Regulator Single Stage	HSR2570	0781-3873	5-50*	--	--	580	5/8"-18 RH F	3000
HSR Medium Duty Flow Meter Regulator Single Stage	HSR2570	0781-3869	4-40*	--	--	580	5/8"-18 RH F	3000
HVTS Medium Duty Flow Meter Regulator Two Stage	HVTS2570	0781-3774	20-150*	--	--	580	5/8"-18 RH F	3000

\*Delivery range measured in CFH

GAS CONTROL

**Regulator Selection Guide - By Gas Service**

**British Oxygen**

Description	Model	Part Number	Delivery Range (psig)	Gauge Range Inlet	Gauge Range Outlet	CGA Inlet Connection	Outlet Connection	Max Inlet Pressure (psig)
ESS7 High Capacity Single Stage	ESS7-200-992	0781-5220	10-200	4000	400	992	7/8" – 14 M RH	3000
ESS4 High Capacity Single Stage	ESS4-200-992	0781-5155	10-200	4000	400	992	9/16" – 18 M RH	3000
ESS4 High Capacity Single Stage	ESS4-125-992	0781-5128	5-125	4000	200	992	9/16" – 18 M RH	3000
ETS4 High Capacity Two Stage	ETS4-125-992	0785-2120	5-125	4000	200	992	9/16" – 18 M RH	3000
ETS4 High Capacity Two Stage	ETS4-200-992	0785-2121	10-200	4000	400	992	9/16" – 18 M RH	3000
DL700 Dome Load	DL700	0780-1188	5-125	–	–	1/2" NPT F	1/2" NPT F	500

**Methane/Hydrogen**

Description	Model	Part Number	Delivery Range (psig)	Gauge Range Inlet	Gauge Range Outlet	CGA Inlet Connection	Outlet Connection	Max Inlet Pressure (psig)
ESS7 High Capacity Single Stage	ESS7-200-350	0781-5186	10-200	4000	400	350	7/8" – 14 M RH	3000
ESS42 EDGE 2.0 High Capacity Single Stage	ESS42-150-350	0781-3612	5-150	4000	200	350	1/4" – 18 F	3000
ETS4 High Capacity Two Stage	ETS4-40-350	0781-5225	2-40	4000	60	350	9/16" – 18 M LH	3000
VTS 250 Medium Duty Two Stage	VTS252A-350	0781-3558	2-15	4000	30	350	9/16" – 18 M LH	3000
VTS 250 Medium Duty Two Stage	VTS252B-350	0781-3559	2-40	4000	60	350	9/16" – 18 M LH	3000
VTS 250 Medium Duty Two Stage	VTS252C-350	0781-3563	4-80	4000	100	350	9/16" – 18 M LH	3000
VTS 250 Medium Duty Two Stage	VTS252D-350	0781-3564	5-125	4000	200	350	9/16" – 18 M LH	3000
SR 4 High Pressure Manifold	SR4F-350	0781-1404	50-750	4000	1000	350	1/4" Swagelok®	3000
SR 4 High Pressure Manifold	SR4G-350	0781-1424	100-1500	4000	2000	350	1/4" Swagelok	3000
SR 4 High Pressure Manifold	SR4J-350	0781-1444	200-3000	4000	4000	350	1/4" Swagelok	3000
ESL4 High Capacity Line	ESL4-80-250F	0781-5210	4-80	–	100	1/4" NPT F	1/4" NPT F	3000
ESL4 High Capacity Line	ESL4-125-250F	0781-5211	5-125	–	200	1/4" NPT F	1/4" NPT F	3000
EST4 High Capacity Station	EST4-80-025	0781-5195	4-80	–	100	025	9/16" – 18 M LH	200
EST4 High Capacity Station	EST4-80-025R	0781-5212	4-80	–	100	025	9/16" – 18 M LH	200
EST4 High Capacity Station	EST4-125-025	0781-5196	5-125	–	200	025	9/16" – 18 M LH	200
EST4 High Capacity Station	EST4-125-025R	0781-5213	5-125	–	200	025	9/16" – 18 M LH	200
L700 High Flow Line	L711D-500	0780-1199	5-125	–	200	1/2" NPT F	1/2" NPT F	350
HSR Medium Duty Flow Meter Regulator Single Stage	HSR2533	0781-3825	5-40*	–	–	350	9/16" – 18 M LH	3000

**Nitrous Oxide**

Description	Model	Part Number	Delivery Range (psig)	Gauge Range Inlet	Gauge Range Outlet	CGA Inlet Connection	Outlet Connection	Max Inlet Pressure (psig)
ESL4 High Capacity Line	ESL4-125-250	0781-5190	5-125	–	200	1/4" NPT F	1/4" NPT F	3000
DL700 Dome Load	DL700	0780-1188	5-125	–	–	1/2" NPT F	1/2" NPT F	500

GAS CONTROL

## Regulator Selection Guide - By Gas Service

### Carbon Dioxide

Description	Model	Part Number	Delivery Range (psig)	Gauge Range Inlet	Gauge Range Outlet	CGA Inlet Connection	Outlet Connection	Max Inlet Pressure (psig)
ESS42 EDGE 2.0 High Capacity Single Stage	ESS42-150-320	0781-3615	5-150	4000	400	320	CGA 032 5/8" – 15 F RH	3000
ESS32 EDGE 2.0 Medium Capacity Single Stage	ESS32-150-320	0781-3638	0-150	4000	200	320	CGA 032 5/8" – 15 F RH	3000
ETS4 High Capacity Two Stage	ETS4-125-320	0781-5228	5-125	4000	200	320	CGA 032 5/8" – 18 UNF	3000
VTS 250 Medium Duty Two Stage	VTS253A-320	0781-3569	2-15	4000	30	320	CGA 032 5/8" – 18 UNF	3000
VTS 250 Medium Duty Two Stage	VTS253B-320	0781-3573	2-40	4000	60	320	CGA 032 5/8" – 18 UNF	3000
VTS 250 Medium Duty Two Stage	VTS253C-320	0781-3574	4-80	4000	100	320	CGA 032 5/8" – 18 UNF	3000
VTS 250 Medium Duty Two Stage	VTS253D-320	0781-3575	5-125	4000	200	320	CGA 032 5/8" – 18 UNF	3000
SR 4 High Pressure Manifold	SR4F-320	0781-1401	50-750	4000	1000	320	CGA 032 5/8" – 18 UNF	3000
ELC4 High Capacity Liquid Cylinder	ELC4-125-320R	0781-5201	5-125	–	200	320	CGA 032 5/8" – 18 UNF	3000
ESL4 High Capacity Line	ESL4-125-250	0781-5190	5-125	–	200	1/4" NPT F	1/4" NPT F	3000
DL700 Dome Load	DL700	0780-1188	5-125	–	–	1/2" NPT F	1/2" NPT F	500
ESS3-FG Flow Gauge	ESS3-FG-320	0781-5119	0-40*	4000	50 CFH	320	CGA 032 5/8" – 18 UNF	3000
SR310 Regulator Adjustable Pressure	SR310	0781-0355	10-150*	1500	200	320	CGA 032 5/8" – 18 UNF	1500
SR311 Flow Meter	SR311	0781-0353	25-100*	1500	–	320	CGA 032 5/8" – 18 UNF	1500
SR312 Flow Gauge	SR312	0781-0354	0-100*	–	–	320	CGA 032 5/8" – 18 UNF	1500
FM200 Heavy Duty Flow Meter	FM200	1000-0264	30-100*	–	–	1/4" NPT M	5/8"-18RH M	30
FM370 Flow Meter Heavy Duty	FM370	1000-0258	5-40*	–	–	9/16"-18 RH F	5/8"-18 RH F	25
FM371 Flow Meter Heavy Duty	FM371	1000-0259	5-40*	–	–	5/8"-18 RH M	5/8"-18 RH F	25
FM372 Flow Meter Heavy Duty	FM372	1000-0182	5-40*	–	–	1/4" NPT M	5/8"-18 RH F	25
HRF2480 Medium Duty Flow Meter Regulator	HRF2480	0781-2727	10-38*	–	–	320	5/8"-18 RH F	3000
HRF2480 Medium Duty Flow Meter Regulator	HRF2480	0781-2728	7.5-37.5*	–	–	320	5/8"-18 RH F	3000
DMF150 Medium Duty Flow Meter Regulator	DMF150S	0781-1206	5-40*	–	–	1/4" NPT M	5/8"-18 RH F	3000
HSR Medium Duty Flow Meter Regulator	HSR2530	0781-3819	10-60*	–	–	580	5/8"-18 RH F	3000

\*Delivery Range measured in CFH

### L.P. Gas

Description	Model	Part Number	Delivery Range (psig)	Gauge Range Inlet	Gauge Range Outlet	CGA Inlet Connection	Outlet Connection	Max Inlet Pressure (psig)
ESS7 High Capacity Single Stage	ESS7-125-510LP	0781-5188	5-125	400	200	510	7/8" – 14 M LH	350
ESS42 EDGE 2.0 High Capacity Single Stage	ESS42-60-510LP	0781-3606	2-60	510	60	510	9/16" – 18 M LH	350
ESS42 EDGE 2.0 High Capacity Single Stage	ESS42-150-510LP	0781-3607	2-150	510	200	510	9/16" – 18 M LH	350
ESS32 EDGE 2.0 Medium Capacity Single Stage	ESS32-60-510LP	0781-3631	0-60	510	60	510	9/16" – 18 M LH	350
SR450 Heavy Duty Single Stage	SR461B-510	0781-0589	2-40	400	60	510	9/16" – 18 M LH	350
SR450 Heavy Duty Single Stage	SR461D-510	0781-0595	5-125	400	200	510	9/16" – 18 M LH	350
SR 250 Medium Duty Single Stage	SR261B-510	0781-0095	2-40	400	60	510	9/16" – 18 M LH	350
SR 250 Medium Duty Single Stage	SR261C-510	0781-0098	4-80	400	100	510	9/16" – 18 M LH	350
VTS 250 Medium Duty Two Stage	VTS261B-510	0781-3594	2-40	400	60	510	9/16" – 18 M LH	350
VTS 250 Medium Duty Two Stage	VTS250BL-555	0781-3525	2-40	400	60	510	9/16" – 18 M LH	350
ESL4 High Capacity Line	ESL4-80-250F	0781-5210	4-80	–	100	1/4" NPT F	1/4" NPT F	3000
ESL4 High Capacity Line	ESL4-125-250F	0781-5211	5-125	–	200	1/4" NPT F	1/4" NPT F	3000
EST4 High Capacity Station	EST4-80-025	0781-5195	4-80	–	100	025	9/16" – 18 M LH	200
EST4 High Capacity Station	EST4-80-025R	0781-5212	4-80	–	100	025	9/16" – 18 M LH	200
EST4 High Capacity Station	EST4-125-025	0781-5196	5-125	–	20	025	9/16" – 18 M LH	200
EST4 High Capacity Station	EST4-125-025R	0781-5213	5-125	–	200	025	9/16" – 18 M LH	200
L700 High Flow Line	L711D-500	0780-1199	5-125	–	200	1/2" NPT F	1/2" NPT F	350

## Single Stage Regulators

Recommended for applications where slight delivery pressure increases (due to decreasing cylinder pressures) would not affect the performance characteristics of the work or test results.

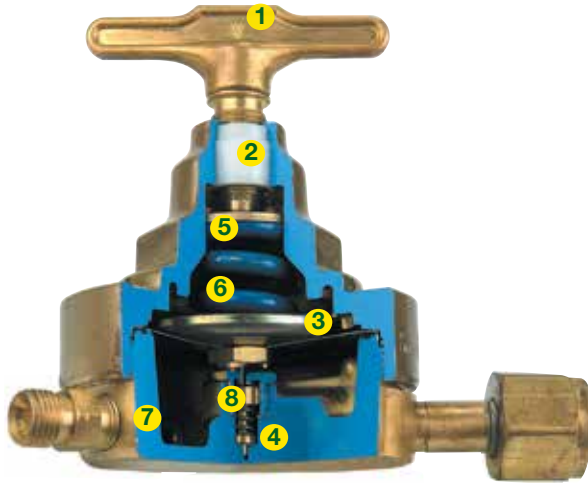

Typical Single Stage Design SR 450 Series Shown  
2.5 in. (63.5 mm) Brass Gauges External Relief Valve System

- 1 Brass Adjusting Screw with forged T-handle (SR 450 only)
- 2 Delrin Insert Bushing for durability, easier adjusting
- 3 Stainless Steel Diaphragm gives accurate long lasting service
- 4 Stem-Type Seat Mechanism inlet pressure aids in sealing
- 5 Stainless Ball in Key for easy adjustment
- 6 Adjusting Spring pretested for quality assurance
- 7 Die-Forged Brass Body for extra strength
- 8 Precision Machined Nozzle for optimum flow control

### Additional Features

- External self reseating relief valve. Not designed to protect downstream equipment (no relief valve is needed on low pressure fuel gas models)
- Sintered inlet filter, electroless nickel plated bronze
- Regulators will deliver at least the stated upper range and in some cases may exceed the stated upper range

## Two Stage Regulators

Recommended for applications that require a constant delivery pressure over a range of decreasing inlet pressures. This precise two stage regulator provides superior operating characteristics for applications where change in delivery pressure would affect performance characteristics of work or test results.

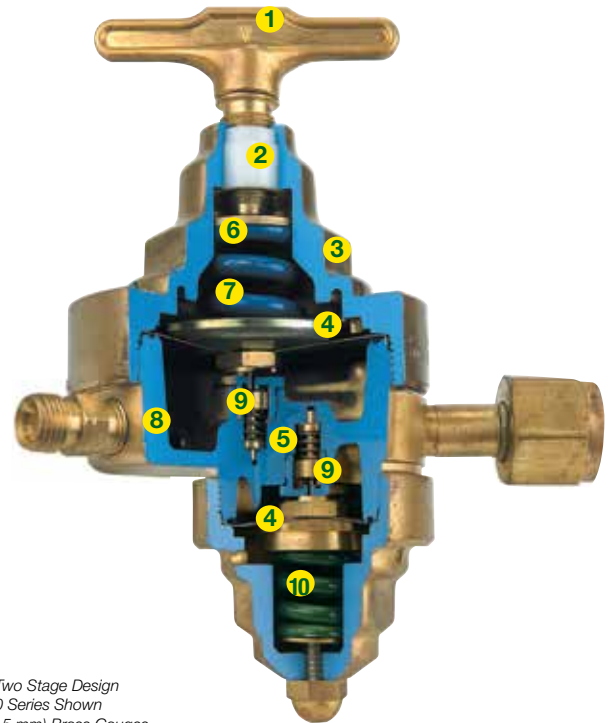

Typical Two Stage Design  
VTS 450 Series Shown  
2.5" (63.5 mm) Brass Gauges  
External Relief Valve System

### Additional Features

- 1 Brass Adjusting Screw with forged T-handle (VTS 700 only)
- 2 Delrin Insert Bushing for durability, easier adjusting
- 3 Die-Forged Brass Spring Housing Cap provides greater strength and durability
- 4 Stainless Steel Diaphragm gives accurate long lasting service
- 5 Stem-Type Seat Mechanism inlet pressure aids in sealing
- 6 Stainless Ball in Key for easy adjustment
- 7 Adjusting Spring pretested for quality assurance
- 8 Die-Forged Brass Body for extra strength
- 9 Precision Machined Nozzle for optimum flow control
- 10 Adjusting Spring designed for precise preset

### Additional Features

- External self reseating relief valve. Not designed to protect downstream equipment (no relief valve is needed on low pressure fuel gas models)
- Sintered inlet filter, electroless nickel plated bronze
- Regulators will deliver at least the stated upper range and in some cases may exceed the stated upper range

## EDGE™ Series

Innovative EDGE Series Regulators Offer Safety and Advanced Design

Victor has been the leader in gas equipment for one hundred years, and its tradition of unparalleled safety remains a cornerstone of the brand today. With the Victor Professional EDGE Series Regulators, Victor continues to offer the safest, most reliable and highest quality gas control technology, giving you more value for your purchase. In addition, standardized designs and components throughout the EDGE family greatly simplify regulator service and repair.

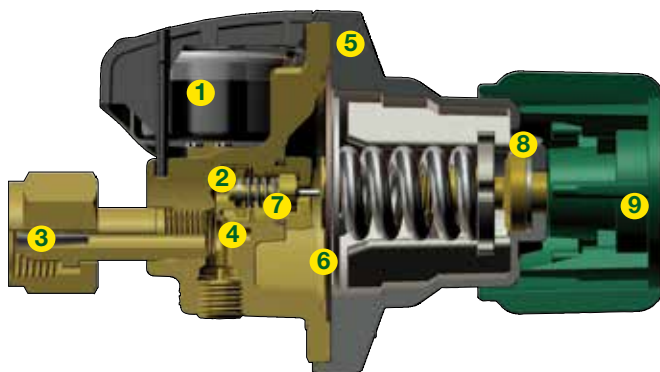

- 1 Gauges are recessed into the body for the highest level of safety and protection possible
- 2 More efficient internal flow paths translate to improved flow consistency from full to empty cylinder
- 3 Same sintered inlet filter used in all Victor industrial regulators
- 4 Innovative design elements enable the regulator to meet or exceed oxygen-related safety standards CGA E-4, UL 252, and the stringent ASTM G-175 Promoted Ignition Test
- 5 Housing cap is made from high strength zinc-aluminum alloy that has nearly twice the yield strength of forged brass
- 6 Time-tested fabric reinforced neoprene diaphragm provides superior sensitivity and control
- 7 Seat assembly and friction damper are the same tried and true components used for decades in SR 350 and SR 450
- 8 Internals remain protected from weather elements through an internal vent system protected under the knob, which is channeled to promote water run-off
- 9 SLAM™ Knob designed with multi-stage crumple zones which absorb impact energy in the event the cylinder falls over. Helps protect pressure integrity of both regulator and cylinder valve.

## EDGE 2.0 Series Regulators

High and medium capacity, single stage regulators

Victor EDGE™ Series 2.0 patented regulators are second generation, heavy-duty, high capacity single stage cylinder regulators that reset the standard for industrial regulators.

New and improved gauge designs incorporate larger faced delivery gauge (low pressure) with high contrasted colored face for easy setting. Enhanced color-coded knob designs provide more comfortable operations.

Air, Oxygen, Inert Gas, Methane, Hydrogen, Carbon Dioxide, Acetylene and LP Gas (see ordering information).

- Forged brass body
- External self reseating relief valve. Not designed to protect downstream equipment (no relief valve is needed on low pressure fuel gas models).
- Fully enclosed, highly visible modular gauges for more clarity with robust metal gauge guard
- Extra large 2 1/2 in. (63.5 mm) delivery gauge and stainless steel diaphragm
- Robust seat gives optimum performance
- Consistent pressure and flow delivery
- High resistance to oxygen related fires and SLAM knob absorbs impact in the event of a cylinder fall



Watch the Victor EDGE™ Regulator SLAM Safety Video

[www.youtube.com/watch?v=35ejr42XFmM](http://www.youtube.com/watch?v=35ejr42XFmM)



Single Impact Point

### 3-Stage Crumple Zone

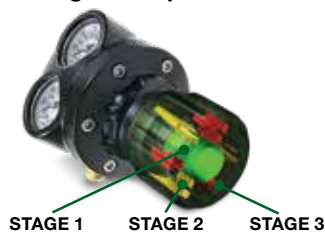

Shock Absorbing Knob

## ESS7 High Flow

### Design/Construction

- 2.5 in. (63.5 mm) gauges – brass
- 2.7 in. (68.6 mm) diaphragm – fabric reinforced neoprene



### ESS7 Flow Data - EDGE Series High-Flow

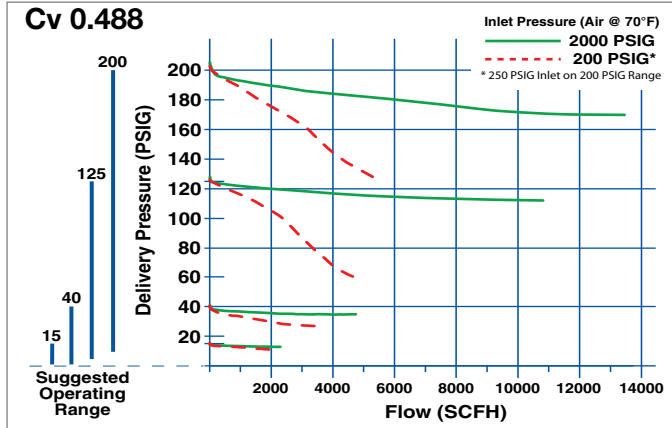

### Specifications

Dimensions L x W x H	Weight
5.4 x 6.8 x 6.9 in. (137.1 x 172.7 x 175.3 mm)	4.9 lb (2.22 kg)

### Ordering Information

Gas Service	Part No.	Model No.	Delivery Range
Air, Oxygen, Inert Gas	0781-5184	ESS7-200-346	10-200
	0781-5181	ESS7-125-540	5-125
	0781-5183	ESS7-200-540	10-200
	0781-5220	ESS7-200-992	10-200
	0781-5182	ESS7-125-580	5-125
	0781-5185	ESS7-200-580	10-200
Methane/Hydrogen	0781-5186	ESS7-200-350	10-200
Acetylene	0781-5187	ESS7-15-510	2-15
L.P. Gas	0781-5188	ESS7-125-510LP	5-125

Outlet Connection 7/8"-14(M) like other regulators



### EDGE ADJUSTING LOCK

Ideal for setting pressures and avoiding tampering by others. Comes with three color decals - red, green, black.

Part No: 0750-0221 ● ● ●

## ESS42 EDGE 2.0 High capacity, single stage

### Design/Construction

- Fully enclosed, highly visible modular gauges for more clarity with robust metal gauge guard
- Extra large 2 1/2 in. (63.5 mm) delivery gauge and stainless steel diaphragm
- Robust seat gives optimum performance
- Consistent pressure and flow delivery
- High resistance to oxygen related fires and SLAM knob absorbs impact in the event of a cylinder fall



[esab.com/edge2](http://esab.com/edge2)

### ESS42 Flow Data

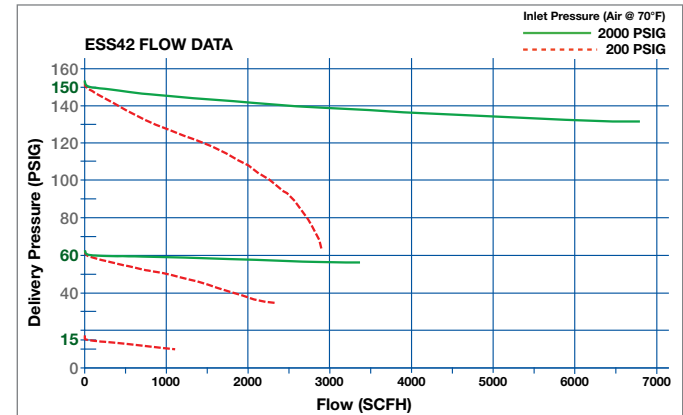

### Specifications

Dimensions L x W x H	Weight
4 x 6 x 4 in. (101.6 x 152.4 x 101.6 mm)	4.0 lb (1.81 kg)

### Ordering Information

Gas Service	Part No.	Model No.	Delivery Range (psig)
Air, Oxygen, Inert Gas	0781-3600	ESS42-60-540 Oxygen	2-60
	0781-3601	ESS42-150-540 Oxygen	5-150
	0781-3613	ESS42-150-346 Air	5-150
	0781-3614	ESS42-150-590 Air	5-150
	0781-3609	ESS42-150-580 Inert Gas	5-150
Methane/Hydrogen	0781-3612	ESS42-150-350	5-150
Acetylene	0781-3602	ESS42-15-510	2-15
	0781-3603	ESS42-15-300	2-15
	0781-3604	ESS42-15-993	2-15
	0781-3605	ESS42-15-410	2-15
L.P. Gas	0781-3606	ESS42-60-510LP	2-60
	0781-3607	ESS42-150-510LP	2-150
Carbon Dioxide	0781-3615	ESS42-150-320	5-150

## ESS32 EDGE 2.0

Medium capacity, single stage

### Design/Construction

- Fully enclosed, highly visible modular gauges for more clarity with robust metal gauge guard
- Large 2 in. (50.8 mm) delivery gauge
- Robust seat gives optimum performance
- Consistent pressure and flow delivery
- High resistance to oxygen related fires and SLAM knob absorbs impact in the event of cylinder fall



esab.com/edge2

### ESS32 Flow Data

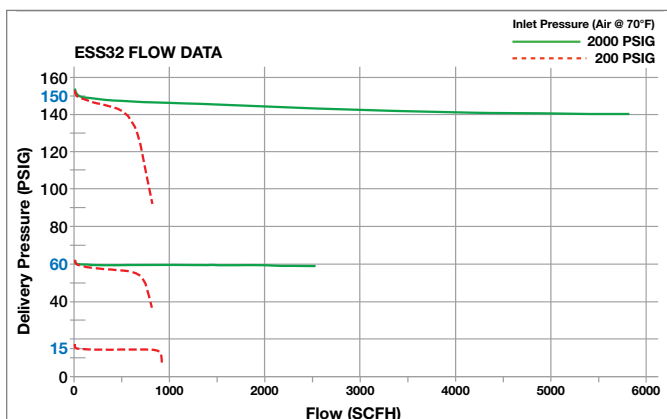

### Specifications

Dimensions L x W x H	Weight
4 x 6 x 4 in. (101.6 x 152.4 x 101.6 mm)	4.0 lb (1.81kg)

### Ordering Information

Gas Service	Part No.	Model No.	Delivery Range
Air, Oxygen, Inert Gas	0781-3627	ESS32-60-540 S/S Oxygen	0-60 psig
	0781-3626	ESS32-150-540 S/S Oxygen	0-150 psig
	0781-3633	ESS32-60-580 Inert	0-60 psig
	0781-3634	ESS32-60-580 Inert	0-150 psig
	0781-3637	ESS32-150-346 S/S Air	0-150 psig
Methane/Hydrogen	0781-3635	ESS32-60-350 S/S Hydrogen	0-60 psig
	0781-3636	ESS32-150-350 S/S Hydrogen	0-150 psig
Acetylene	0781-3628	ESS32-15-510 S/S Acetylene	0-15 psig
	0781-3629	ESS32-15-300 S/S Acetylene	0-15 psig
L.P. Gas	0781-3631	ESS32-60-510LP S/S LP	0-60 psig
Carbon Dioxide	0781-3638	ESS32-150-320 S/S CO2	0-150 psig
Ar-CO2	0781-3641	ESS32-80CFH-580 Ar-CO2 Flowgauge	0-80 cfh
	0781-3642	ESS32-80CFH-320 Ar-CO2 Flowgauge	0-80 cfh

## ESS32-PFH-800

Pressure/flow hybrid regulator

### Design/Construction

- Nitrogen CGA-580 tool-less connection
- Fully enclosed, highly visible modular gauges for optimum clarity with robust metal gauge guard for maximum protection
- SLAM™ (Shock Limitation and Absorption Mechanism) technology built into the adjusting knob, provides additional strength, safety and protection of the regulator
- Up to 800 psi testing pressure



GAS CONTROL

### Specifications

Maximum Inlet	Outlet Connection	Gas Service
3000 psig	1/4 in. SAE Flare	Nitrogen
Controlled Pressure and Flow		
3 – 6 CFH (BRAZE)		
20 – 50 CFH (PURGE)		
200 – 800 PSIG (PRESSURE TEST)		
Operating Temperature		
0° – 120° F (-17.9 – 48.9° C)		
Storage Temperature		
-20° – 140° F (-28.9 – 60° C)		

### Ordering Information

ESS32-PFH-580 Pressure-Flow Hybrid Regulator	0781-3652
--	-----------

## SR 450 Heavy-duty

### Design/Construction

- 2.5 in. (63.5 mm) gauges – brass
- 3.25 in. (82.6 mm) diaphragm – stainless steel

The shape of the SR450 Series regulator is a registered trademark of Victor.



## SR 350 Heavy/medium-duty

### Design/Construction

- High impact ABS gauge guard
- 1.5 in. (40 mm) gauges steel
- 2.7 in. (68.6 mm) diaphragm – fabric reinforced neoprene



### Flow (SCFH)

**Cv 0.27**

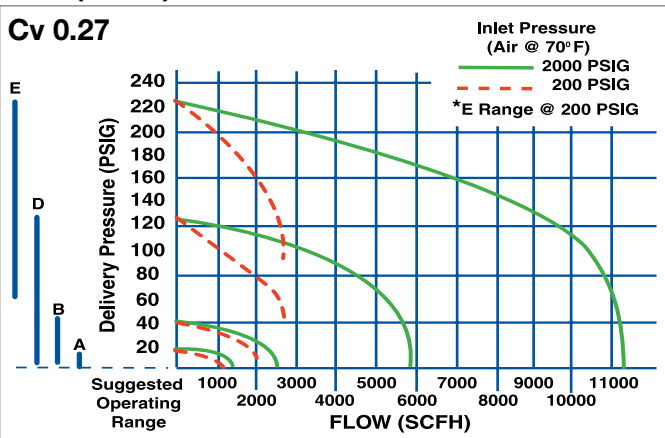

### SR350 Flow Data - (Flowing Air at STD. Conditions)

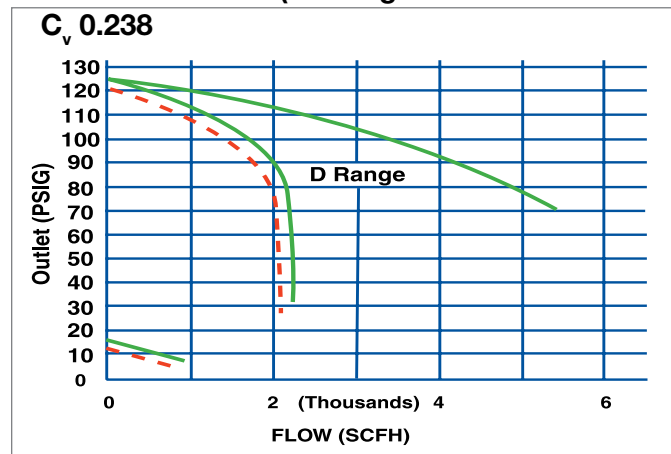

### Specifications

Maximum Inlet	Dimensions L x W x H	Weight
3000 psig	5.13 x 7.25 x 7 in. (130.3 x 184.2 x 177.8 mm)	5 lb 2 oz (2.32 kg)

### Specifications

Maximum Inlet	Dimensions L x W x H	Weight
3000 psig	4.5 x 7.5 x 6.5 in. (114.3 x 190.5 x 165.1 mm)	4 lb (1.8 kg)

### Ordering Information

Gas Service	Part No.	Model No.	Delivery Range (psig)
Air, Oxygen, Inert Gas	0781-0532	SR 450D-346	5-125
	0781-0527	SR 450D-540	5-125
	0781-0528	SR 450D-580*	5-125
	0781-0543	SR 450E-580*	10-200
Acetylene	0781-0583	SR 460A-300	2-15
	0781-0584	SR 460A-510	2-15
L.P. Gas	0781-0589	SR 461B-510	2-40
	0781-0595	SR 461D-510	5-125

Outlet Connections: Cylinder Type – 9/16"-18 (M), \*9/16"-18 (F) RH

### Ordering Information

Gas Service	Part No.	Model No.	Delivery Range (psig)
Oxygen	0781-2341	SR 350D-540	5-125
Acetylene	0781-2400	SR 360A-300**	2-15
	0781-2401	SR 360A-510	2-15

Outlet Connections: Cylinder Type – 9/16"-18 (M), \*\*9/16"-18 (M) LH



## SR 250

Medium-duty

### Design/Construction

- 2" (50.8 mm) gauges – brass
- 1.75" (44.5 mm) diaphragm – fabric reinforced neoprene



## G350

Heavy-duty

### Design/Construction

- Larger regulator body for heavy duty applications
- Color coded knobs
- Forged brass body and Zinc Aluminum housing cap
- 2 in. (50.8 mm) gauges
- 9/16"-18 outlet connection
- Internal relief



### SR250 Flow Data

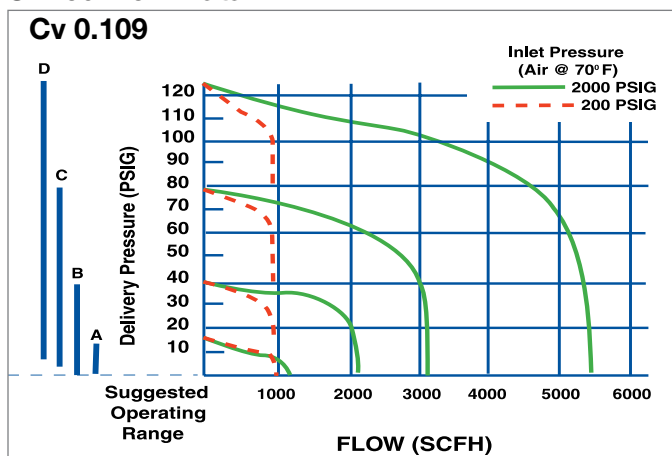

### G350 Flow Data

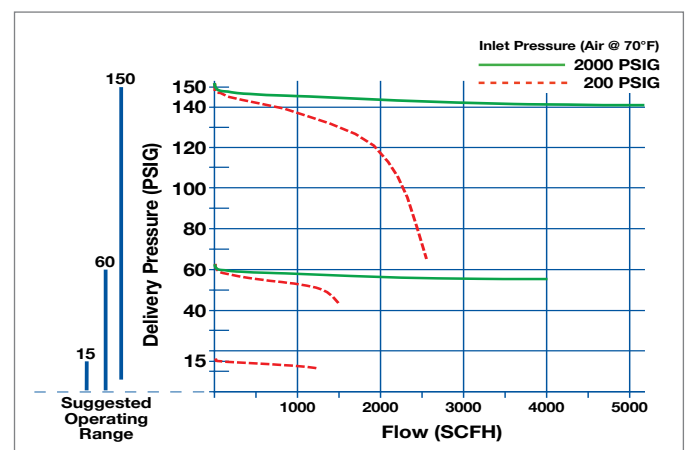

### Specifications

Maximum Inlet	Dimensions L x W x H	Weight
3000 psig	4.25 x 6.38 x 5.13 in. (108 x 162 x 130.3 mm)	2 lb 15 oz (1.3 kg)

### Ordering Information

Gas Service	Part No.	Model No.	Delivery Range (psig)
Oxygen	0781-0027	SR 250C-540	4-80
	0781-0043	SR 250D-540	5-125
Acetylene	0781-0085	SR 260A-300	2-15
	0781-0087	SR 260A-510	2-15
	0387-0115	SR 260A-510 CS	2-15
L.P. Gas	0781-0095	SR 261B-510	2-40
	0781-0098	SR 261C-510	4-80

CS = Clamshell Packaging  
 Outlet Connections: Cylinder Type – 9/16"-18 (M)

### Ordering Information

Gas Service	Part No.	Model No.	Delivery Range (psig)
Oxygen	0781-9415	G350-150-540	150
Acetylene	0781-9421	G350-15-300	15
Inert	0781-9416	G350-150-580	150
	0781-9420	G350-15-510	15
LP	0781-9422	G350-60-510LP	60

## G250

Medium-duty

### Design/Construction

- Compact size for light to medium duty applications
- Acetylene, Oxygen and LP gas models
- Color coded knobs
- Single stage
- Forged brass body & Zinc Aluminum housing cap
- 2 in. (50.8 mm) gauges
- Delivery ranges vary based on model (see ordering information)
- 9/16"-18 outlet connection
- Internal relief



## G150

Light-duty, single stage, cylinder regulator

The G150 series, single stage, cylinder regulator is a compact, light weight regulator engineered for light duty applications.

### Design/Construction

- Ergonomic color-coded adjustment knob
- High contrast gauge face
- High strength alloy bonnet
- Compact design



GAS CONTROL

### G250 Flow Data

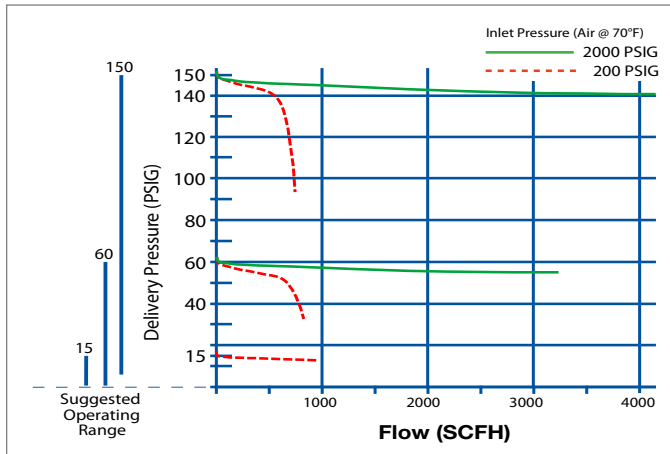

### Ordering Information

Gas Service	Part No.	Model No.	Delivery Range (psig)
Oxygen	0781-9400	G250-150-540	150
Acetylene	0781-9405	G250-15-510	15
	0781-9406	G250-15-300	15
LP	0781-9410	G250-60-510LP	60

### Ordering Information

G150-60-540	0781-4227
G150-60-540R	0781-4228
G150-60-540R 020 "A"	0781-4241
G150-15-510	0781-4233
G150-15-200	0781-4231
G150-15-200R	0781-4232
G150-15-200R 021 "A"	0781-4240
G150-15-520	0781-4235
G150-60-510LP	0781-4234
G150-60-580	0781-4229
G150-60-580 w/ hose	0781-4236
GF150-50-580 flowgauge	0781-4226
G150-60-320	0781-4230
GF150-50-320 w/ hose	0781-4237
GF150-50-320 flowgauge	0781-4225
SLR150 surge limiting	0781-1207

## VTS 700

Extra heavy-duty,  
two stage, high flow

### Design/Construction

- 2.5 in. (63.5 mm) gauges – steel
- Diaphragms – 2 in. (50.8 mm) and 3.25 in. (82.6 mm) – stainless steel



### VTS 700 Flow Data

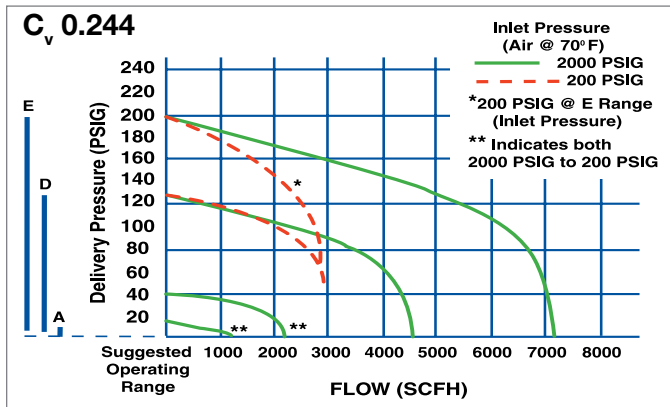

### Specifications

Maximum Inlet	Dimensions L x W x H	Weight
3000 psig	8.63 x 6.75 x 7.5 in. (219 x 171.5 x 190.5 mm)	8 lb 8 oz (3.86 kg)

### Ordering Information

Gas Service	Part No.	Model No.	Delivery Range (psig)
Oxygen, Inert Gas	0780-0928	VTS 700D-580	5-125
	0780-0939	VTS 700E-540	10-200
	0780-0943	VTS 700E-580	10-200
Acetylene	0780-0984	VTS 710A-510	2-15

Outlet Connections: 7/8"-14(M)

## VTS 250

Medium-duty,  
two stage

### Design/Construction

- Delrin Insert Bushing for durability, easier adjusting
- Die-Forged Brass Spring Housing Cap provides greater strength and durability
- Fabric reinforced neoprene diaphragm gives long lasting service
- Stem-Type Seat Mechanism inlet pressure aides in sealing
- Stainless Ball in adjusting screw for easy adjustment
- Die-Forged Brass Body for extra strength
- Precision Machined Nozzle for optimum flow control
- Adjusting Spring designed for precise adjustment



### Additional Features

- External self reseating relief valve - Not designed to protect downstream equipment (no relief valve is needed on low pressure fuel gas models)
- Sintered inlet filter - electroless nickel plated bronze
- Regulators will deliver at least the stated upper range and in some cases may exceed the stated upper range

### Ordering Information

Gas Service	Part No.	Model No.	Delivery Range (psig)
Oxygen,	0781-3503	VTS250A-540	2-15
	0781-3504	VTS250B-540	2-40
	0781-3505	VTS250C-540	4-80
	0781-3506	VTS250D-540	5-125

Outlet Connections: 9/16"-18 (M RH)

## ETS4 Series

High capacity,  
two-stage design

### Design/Construction

- Forged brass body
- Zinc-aluminum housing caps
- High impact ABS gauge guard
- 1.5 in. UL listed/recognized gauges – brass
- Stem type seat mechanism: urethane seat material – air, oxygen, inerts, CO<sub>2</sub>, N<sub>2</sub>O, other high pressure gases; neoprene seat material – low pressure fuel gases
- 2.7 in. fabric reinforced neoprene diaphragm in 2nd stage, 0.75 in. diameter brass piston in 1st stage
- External self reseating relief valve. Not designed to protect downstream equipment (no relief valve is needed on low pressure fuel gas models)
- Sintered inlet filter – nickel plated bronze
- SLAM impact absorbing safety knob
- Meets or exceeds CGA E-4, UL 252 and ASTM G-175 Promoted Ignition Test



## EHP Series

High pressure

Developed specifically for applications which require higher deliver pressure (400 or 800 PSIG maximum) Provides even higher deliver capability than the SR 600 it's replacing.

### Design/Construction

- Replaces SR 600 series
- Forged brass body
- High strength Zinc-Aluminum house cap
- High impact ABS gauge guard
- Color-coded SLAM impact absorbing safety knob



GAS CONTROL

### Specifications

Maximum Inlet	Dimensions L x W x H	Weight
3000 psig	6.25 x 6 x 6.5 in. (158.8 x 152.4 x 165 mm)	4 lb (1.81 kg)

### Ordering Information

Gas Service	Part No.	Model No.	Delivery Range (psig)
Oxygen	0781-5170	EHP3-800-540	50-750
Inert Gas	0781-5168	EHP3-400-680	50-750
	0781-5171	EHP3-800-580	50-750
Air	0781-5169	EHP3-400-347	50-750

Inlet: \*1/4" NPT(F)  
Outlet Fitting: 1/4" Swagelok type stainless steel.  
+5/8"-20 UNF(M) inlet 1/8" NPT(F) outlet

### ETS4 Flow Data

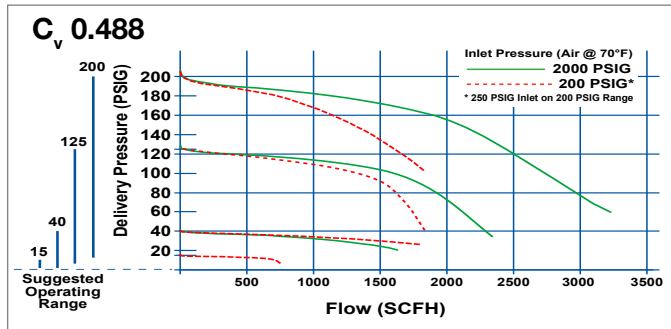

### Specifications

Dimensions L x W x H	Weight
4.72 x 6.85 x 4.4 in. (120 x 174 x 111.8 mm)	4 lb 12 oz (2.15 kg)

### Ordering Information

Gas Service	Part No.	Model No.	Delivery Range (psig)
Air, Oxygen, Inert Gas	0781-5231	ETS4-125-346	5-125
	0781-5232	ETS4-200-346	10-200
	0781-5217	ETS4-40-540	2-40
	0781-5218	ETS4-125-540	5-125
	0781-5219	ETS4-200-540	10-200
	0781-5221	ETS4-40-580	20-40
	0781-5222	ETS4-125-580	5-125
	0781-5223	ETS4-200-580	10-200
Industrial Air	0781-5224	ETS4-125-590	5-125
British Oxygen/Fuel	0785-2120	ETS4-125-992	5-125
	0785-2121	ETS4-200-992	10-200
Hydrogen/Methane	0785-2122	ETS4-15-993	2-15
	0781-5225	ETS4-40-350	2-40
Carbon Dioxide	0781-5226	ETS4-125-350	5-125
	0781-5227	ETS4-200-350	10-200
Acetylene	0781-5228	ETS4-125-320	5-125
	0781-5229	ETS4-15-300	2-15
	0781-5230	ETS4-15-510	2-15

## SR 4 High pressure

Heavy-duty, high pressure piston regulator. Ideally suited for pressure vessel and dead-end testing. Delivery pressures up to 4500 psig on some models.

### Design/Construction

- Machined brass body & housing cap
- 2.5 in. (63.5 mm) gauges – brass
- Cartridge type seat assembly with PCTFE seat
- Piston type actuation – brass
- Delrin cap bushing for smooth adjustments
- External adjustable relief valves on F and G range models
- Hydrogen models have ventable relief valves (J Series does not)
- Sintered inlet filter – bronze

### Panel Mounting Details

- All SR 4 Series regulator models may be panel mounted.
- 1.75 in. (44.5 mm) (hole required in panel for mounting).
- For a flush panel mount installation order one panel mount nut 1409-0093. For an adjustable panel mount installation order two panel mount nuts 1409-0093.



GAS CONTROL

Specifications		
Maximum Inlet	Dimensions L x W x H	Weight
7500 psig with CGA 677 6000 psig without inlet fitting 5500 psig with CGA 701, 680, 347 4000 psig with CGA 577 3000 psig with CGA 540, 580, 346, 350	6.25 x 6 x 6.5 in. (158.8 x 152.4 x 165.1 mm)	4 lb (1.81 kg)

Ordering Information			
Gas Service	Part No.	Model No.	Delivery Range (psig)
Oxygen	0781-1405	SR 4F-540	50-750
	0781-1425	SR 4G-540	100-1500
	0781-1445	SR 4J-540	200-3000
Inert Gas	0781-1408	SR 4F-580	50-750
	0781-1410	SR 4F-680	50-750
	0781-1428	SR 4G-580	100-1500
	0781-1430	SR 4G-680	100-1500
	0781-1448	SR 4J-580	200-3000
	0781-1450	SR 4J-680	200-3000
	0781-1453	SR 4J-677	200-3000
	0781-1470	SR 4K-680	300-4500
	0781-1473	SR 4K-677	300-4500
	Air	0781-1403	SR 4F-347
0781-1422		SR 4G-346	100-1500
0781-1442		SR 4J-346	200-3000
0781-1463		SR 4K-347	300-4500
Methane, Hydrogen	0781-1404	SR 4F-350	50-750
	0781-1424	SR 4G-350	100-1500
	0781-1444	SR 4J-350	200-3000
CO <sub>2</sub>	0781-1401	SR 4F-320	50-750
Panel Mount 1/4" NPT Inlet	0781-1415	*SR 4PF-250	50-750
	0781-1420	*SR 4PG-250	100-1500
	0781-1455	*SR 4PJ-250	200-3000
	0781-1475	+SR 4PK-250	300-4500
	0781-1454	SR 4TJ-996	200-3000

*Inlet: 1/4" NPT(F)  
Outlet Fitting: 1/4" Swagelok type stainless steel.  
+5/8"-20 UNF(M) inlet 1/8" NPT(F) outlet*

### SR 4 FLOW DATA

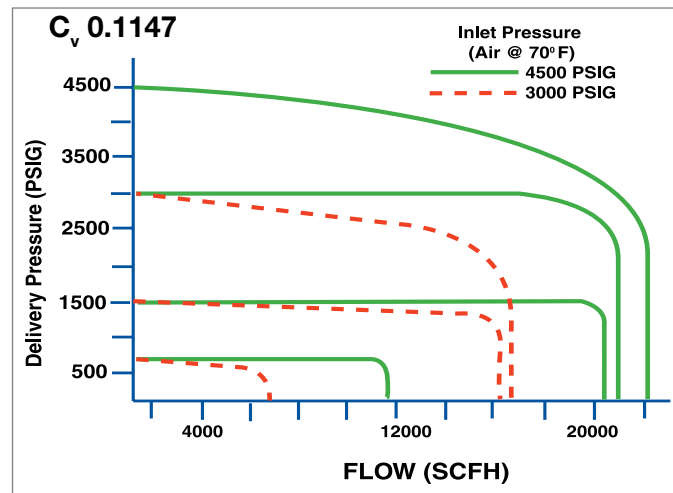

## ELC4

Liquid cylinder

### Design/Construction

- Stainless diaphragm
- Rear entry design



## ESL4

Line regulator

### Design/Construction

- Versatile – supports a variety of inlet pressures (up to 3000 psig)



GAS CONTROL

**ELC4 Flow Data - EDGE Series-Liquid Cylinder**

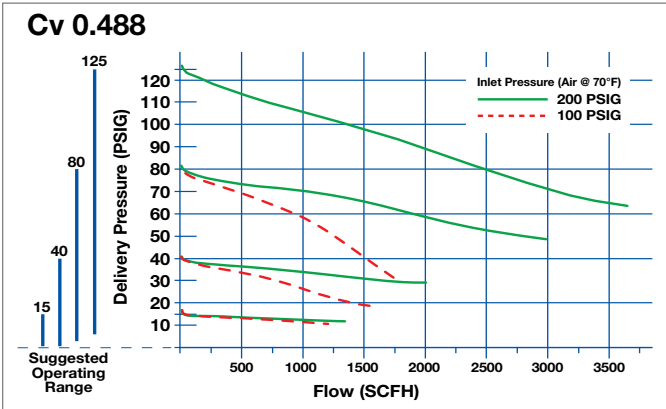

**ESL4 Flow Data - EDGE Series-Line**

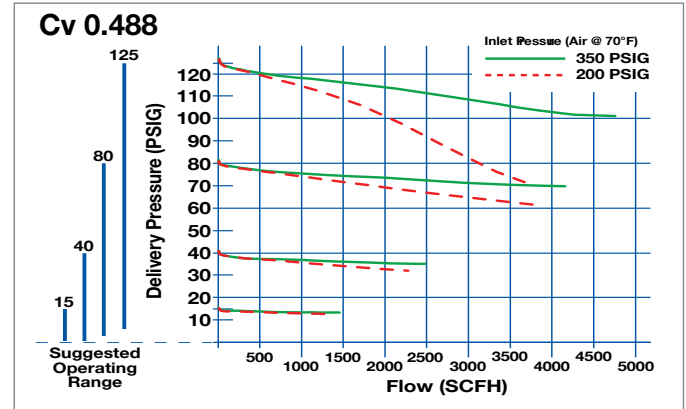

### Specifications

Maximum Inlet	Dimensions L x W x H	Weight
3000 psig	8.2 x 3.8 x 7 in. (208.3 x 96.5 x 180.3 mm)	4 lbs 5 oz (1.95 kg)

### Specifications

Maximum Inlet	Dimensions L x W x H	Weight
3000 psig	8.2 x 3.8 x 7 in. (208.3 x 96.5 x 180.3 mm)	4 lbs 5 oz (1.95 kg)

### Ordering Information

Gas Service	Part No.	Model No.	Delivery Range (psig)
Oxygen	0781-5199	ELC4-125-540R	5-125
Inert (Nitrogen, Argon, Helium)	0781-5200	ELC4-125-580R	5-125
	0781-5202	ELC4-325-580R	5-325
Carbon Dioxide	0781-5201	ELC4-125-320R	5-125

### Ordering Information

Gas Service	Part No.	Model No.	Delivery Range (psig)
Air, Inert Gas, Carbon Dioxide, Nitrous Oxide	0781-5190	ESL4-125-250	5-125
Oxygen	0781-5214	ESL4-125-250X	5-125
Hydrogen, Methane, Natural Gas, L.P. Gas	0781-5210	ESL4-80-250F	4-80
	0781-5211	ESL4-125-250F	5-125
Acetylene	0781-5208	ESL4-15-250A	2-15

## EST4 Station regulator

### Design/Construction

- Side entry and rear entry inlet versions available



## SR 310/311/312 Flow Meter

### Design/Construction

- Designed for CO<sub>2</sub> application (non-siphoned tube cylinders)
- High flow CO<sub>2</sub> applications (SR 310 100 psig) with adequate supply or source
- Designed for core wire applications
- Machined aluminum body & housing cap
- 2 in. (50.8 mm) gauge
- Stem type seat mechanism
- 1.75 in. (44.5 mm) diaphragm - fabric reinforced neoprene
- Self reseating relief valve (not designed to protect downstream equipment)
- Sintered inlet filter - bronze



### EST4 Flow Data - EDGE Series-Station

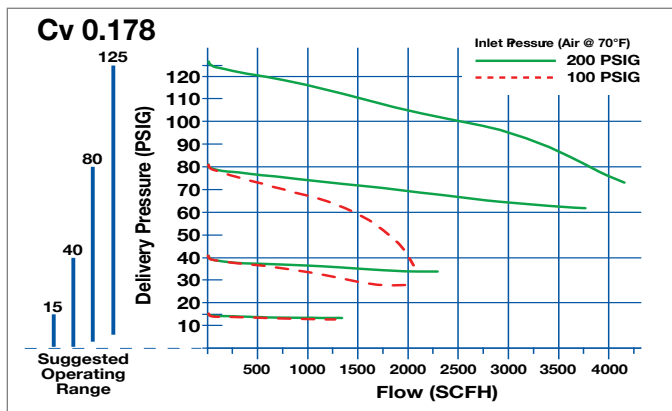

### Specifications

Maximum Inlet	Dimensions L x W x H	Weight
3000 psig	8.2 x 3.8 x 7 in. (208.3 x 96.5 x 180.3 mm)	4 lbs 5 oz (1.95 kg)

### Ordering Information

Gas Service	Part No.	Model No.	Delivery Range (psig)
Oxygen	0781-5191	EST4-40-024	2-40
	0781-5204	EST4-40-024R	2-40
	0781-5192	EST4-80-024	4-80
	0781-5205	EST4-80-024R	4-80
	0781-5193	EST4-125-024	5-125
	0781-5206	EST4-125-024R	5-125
Inert (Nitrogen, Argon, Helium)	0781-5189	EST4-125-034	5-125
	0781-5207	EST4-125-034R	5-125
Acetylene	0781-5194	EST4-15-025	2-15
	0781-5209	EST4-15-025R	2-15
Hydrogen, Methane, Natural Gas, L.P. Gas	0781-5195	EST4-80-025	4-80
	0781-5212	EST4-80-025R	4-80
	0781-5196	EST4-125-025	5-125
	0781-5213	EST4-125-025R	5-125

A regulator equipped with a flow gauge is not accurate when a back pressure in excess of 2 psig exists at the outlet. Back pressure is caused by a restriction in the equipment downstream of the flow gauge. Metering valves, kinked hoses or even very long hoses are restrictions that can cause back pressure. In applications where back pressure in excess of 2 psig can be expected, a regulator equipped with a flow meter should be used.

### Specifications

Maximum Inlet	Delivery Range
1500 psig	100 SCFH
Dimensions L x W x H	Weight
2.5 x 8.38 x 7.25 in. (63.5 x 212.9 x 184.2 mm)	2 lb 15 oz (1.33 kg)

### Ordering Information

Model	Diameter	Part No.
SR 310 Adjustable Pressure Gauge	1.75 in. (44.5 mm)	0781-0355
SR 310 Adjustable Pressure Gauge	2 in. (50.8 mm)	0781-0355
SR 311 (Preset @ 80 psig) Flow Meter	1.75 in. (44.5 mm)	0781-0353
SR 311 (Preset @ 80 psig) Flow Meter	2 in. (50.8 mm)	0781-0353
SR 312 Flow Gauge	1.75 in. (44.5 mm)	0781-0354
SR 312 Flow Gauge	2 in. (50.8 mm)	0781-0354

**WARNING:** High gas withdrawal rates may cause regulator freeze up and will require cylinder manifoldng. Consult your gas supplier. See below for Gas Heater.

## Flow Meter

### Heavy-duty

#### Design/Construction

- Gas flow measurement in SCFH
- MIG / TIG applications
- Flowtube and outer tube are made of impact resistant lexan for severe applications
- Pressure compensated for low surge requirement
- Cover tube contains overpressure protection

All Victor flow meters are back pressure compensated to ensure accurate readings at all times, even if line restrictions are present. All flow meters are calibrated to operate at 25 psig inlet pressure to minimize surge, except the FM 200 which is calibrated to operate at 80 psig.

**WARNING:** Not designed for cylinder use. Do not exceed calibrated inlet pressure.



GAS CONTROL

Ordering Information						
Part No.	Model No.	Flow Range (SCFH)	Inlet Fitting	Outlet Fitting	Replacement Flow Tube	Inlet Pressure (psig)
<b>Units with single gas calibration</b>						
1000-0264	FM 200	30-100 CO <sub>2</sub>	1/4" NPT(M)	5/8"-18 RH(F)	1015-0066	80
<b>Units with 2 gas calibrations</b>						
1000-0268	FM 150	10-60 Air, 10-60 Nitrogen	1/4" NPT(M)	5/8"-18 RH(F)	1015-0060	25
1000-0255	FM 135	4-18 Argon , 10-50 Helium	9/16"-18 RH(F)	5/8"-18 RH(F)	1015-0063	25
1000-0256	FM 145	4-18 Argon, 10-50 Helium	5/8"-18 RH(M)	5/8"-18 RH(F)	1015-0063	25
1000-0257	FM 155	4-18 Argon, 10-50 Helium	1/4" NPT(M)	5/8"-18 RH(F)	1015-0063	25
1000-0261	FM 137	15-65 Argon, 40-200 Helium	9/16"-18 RH(F)	5/8"-18 RH(F)	1015-0064	25
1000-0262	FM 147	15-70 Argon, 40-200 Helium	5/8"-18 RH(M)	5/8"-18 RH(F)	1015-0064	25
1000-0263	FM 157	15-65 Argon, 40-200 Helium	1/4" NPT(M)	5/8"-18 RH(F)	1015-0064	25
<b>Units with 3 gas calibrations</b>						
1000-0258	FM 370	5-40 CO <sub>2</sub> , 5-50 Argon, 20-150 Helium	9/16"-18 RH(F)	5/8"-18 RH(F)	1015-0057	25
1000-0259	FM 371	5-40 CO <sub>2</sub> , 5-50 Argon, 20-150 Helium	5/8"-18 RH(M)	5/8"-18 RH(F)	1015-0057	25
1000-0182	FM 372	5-40 CO <sub>2</sub> , 5-50 Argon, 20-150 Helium	1/4" NPT(M)	5/8"-18 RH(F)	1015-0057	25

To ensure proper gas flow and to prevent tampering to your flowmeter use a Victor Locking Valve(Part No. 0662-0079).



## HRF 2400

### Medium-duty, flow meter

#### Design/Construction

- Regulator / flow meter combination in one compact unit
- MIG / TIG applications
- Ideal for all applications where dependability is needed
- Calibrated tube at 25 psig (not on HRF 2480)
- Machined brass body & housing cap
- Back pressure compensated
- Fabric reinforced neoprene diaphragm
- Internal self reseating relief valve – not designed to protect downstream equipment
- Sintered inlet filter – bronze
- Cover tube contains overpressure protection



**WARNING:** High gas withdrawal rates on carbon dioxide may require cylinder manifolding. Consult your gas supplier.

Specifications	
<b>Maximum Inlet</b>	<b>Outlet Pressure</b>
3000 psig	Preset
<b>Dimensions L x W x H</b>	<b>Weight</b>
3 x 5.63 x 8.25 in. (76.2 x 143 x 209.6 mm)	2 lb 8 oz (1.13 kg)

Ordering Information					
Gas Service	Part No.	Model No.	Flow Range (SCFH)	Specify CGA Inlet Connection	Replacement Flow Tube
Argon, Argon/Carbon Dioxide Mix, Helium	0781-2731	HRF 2425 Preset @ 25 psig	10-50 (Argon), 20-150 (Helium)	580	1015-0057
Carbon Dioxide, Carbon Dioxide Mix	0781-2727	HRF 2480 Preset @ 80 psig	10-38 (CO <sub>2</sub> )	320	1015-0058
	0781-2728	HRF 2480 Preset @ 80 psig	7.5-37.5 (Argon)	320, 580	

*Outlet Connections: 5/8"-18 RH(F), CGA 032*

## DFM 150

### Medium-duty

#### Design/Construction

- Designed to monitor two separate processes or gas flows
- Ideal for applications where shielding gas and back purge requirements are needed
- Designed to offer convenience for the maintenance and fabrication industries
- Brass body
- Teflon seat mechanism
- Sintered inlet filter – bronze
- Music wire – spring
- Piston – brass
- Cover tube – lexan

Specifications	
<b>Maximum Inlet</b>	<b>Outlet Pressure</b>
3000 psig	25 psig (preset)
<b>Dimensions L x W x H</b>	<b>Weight</b>
5 x 5.5 x 6.5 in. (127 x 139.7 x 165.1 mm)	2 lb 9 oz (1.16 kg)



Ordering Information							
Gas Service	Part No.	Model No.	Flow Range (SCFH)	CGA Inlet Connection	Max Inlet (psig)	HP Gauge	Replacement Flow Tube
Argon, Helium	0781-1153	DFM 150-580	5-50 (Argon), 20-150 (Helium)	580	3000	0-4000	1015-0057
Argon, Argon / Carbon Dioxide, Helium Low Pressure	0781-1206	DFM 150S	5-50 (Argon), 5-40 (Argon/CO <sub>2</sub> ) 20-150 (Helium)	1/4" NPT (F)	75	0-100	1015-0057

*Outlet Connection: 5/8"-18 RH(F), CGA 032, Preset Pressure: 25 psig*

## HSR & HVTS

Medium-duty, flow meter

### HSR Models (Single Stage)

#### Design/Construction

- Single or two stage design
- Compact in size
- Accurate regulator for gas flow
- MIG / TIG applications
- Two stage version provides extremely accurate flow rates as cylinder pressure declines
- Low surge rates – 25 psi preset



### HVTS Models (Two Stage)

#### Design/Construction

- Forged brass body and housing cap
- 2 in. (50.8 mm) high pressure gauge
- Stem type seat mechanism
- Fabric reinforced neoprene diaphragm
- External self reseating relief valve (not designed to protect downstream equipment)
- Sintered inlet filter – bronze



**WARNING:** High gas withdrawal rates on carbon dioxide may require cylinder manifolding. Consult your gas supplier.

#### Specifications

Model	Maximum Inlet	Outlet Pressure	Dimensions L x W x H	Weight
HSR	3000 psig	25 psig (preset), 80 psig on CO2	4.25 x 7 x 6.25 in. (108 x 177.8 x 158.8 mm)	3 lb 3 oz (1.45 kg)
HVTS	3000 psig	25 psig (preset), 80 psig on CO2	6.5 x 7 x 5.5 in. (165 x 177.8 x 139.7 mm)	4 lb 10 oz (2.1 kg)

#### Ordering Information

Gas Service	Part No.	Model No.	Flow Range (SCFH)	Specify CGA Inlet Connection	Replacement Flow Tube	Gas Calibrations
Nitrogen/Air	0781-3819	*HSR 2530	10-60	580	1015-0070	2
Argon/Helium	0781-3867	*HSR 2535	4-18 / 10-50	580	-	2
	0781-3775	*HVTS 2535	4-18 / 10-50	580	-	2
	0781-3871	*HSR 2537	15-65 / 40-200	580	1015-0064	2
	0781-3772	*HVTS 2537	15-65 / 40-200	580	1015-0064	2
Argon, Argon/Carbon Dioxide Mix, Helium	0781-3873	*HSR 2570	5-50	580	1015-0057	3
	0781-3869	*HSR 2570	5-40	580	1015-0057	3
	0781-3774	*HVTS 2570	20-150	580	1015-0057	3
Hydrogen	0781-3825	HSR 2533	5-40	350	1015-0070	2
Argon, Argon/Carbon Dioxide, Helium (Max Inlet – 200 psig)	0781-1245	S2570	5-50, 5-40, 20-140	034	1015-0057	3
Inert	0781-3880	HSR 1470-680	50-140-40	680	1015-0057	AR-HE-CO2

\*Outlet Connections: 5/8"-18 RH(F)

## GRF 400

Light-duty, flow meter

### Design/Construction

- Regulator / Flow meter
- Single stage piston design
- Argon, Argon/CO<sub>2</sub> mix & CO<sub>2</sub> models
- 25 psig or 80 psig pre-set pressure
- Up to 50 CFH for Argon and up to 38 CFH for CO<sub>2</sub> delivery
- Available in CGA 320 & 580 inlet connections
- Optional MIG kit available with 10 ft. (3.1 m) hose



Specifications	
<b>Maximum Inlet</b>	<b>Outlet Pressure</b>
3000 psig	Preset
<b>Dimensions L x W x H</b>	<b>Weight</b>
6.25 x 6 x 6.5 in. (158.8 x 152.4 x 165 mm)	2 lb (0.91 kg)

Ordering Information	
0781-2701	GRF400-580
0781-2702	GRF400-580 (with 10' (3.1 m) hose)
0781-2703	GRF400-320
0781-2704	GRF400-320 (with 10' (3.1 m) hose)

*Outlet Connection: CGA 032*

## HRF 1400

Light-duty, flow meter

### Design/Construction

- Regulator / Flow meter
- Single stage piston design
- Argon, Argon/CO<sub>2</sub> mix and CO<sub>2</sub> models
- 25 psig or 80 psig pre-set pressure
- Up to 50 CFH for Argon and up to 38 CFH for CO<sub>2</sub> delivery
- Available in CGA 320 & 580 inlet connections
- Optional MIG kit available with 10 ft. (3.1 m) hose



Specifications	
<b>Maximum Inlet</b>	<b>Weight</b>
3000 psig	2 lb (0.91 kg)
<b>Outlet Pressure</b>	
preset HRF 1425 – 25 psig, HRF 1480 – 80 psig	

Ordering Information	
0781-2723	HRF 1425-580
0387-0240	HRF 1425-580 CS
0781-2743	HRF 1425-580 (with 10' (3.1 m) hose)
0781-2725	HRF 1480-320
0781-2745	HRF 1480-320 (with 10' (3.1 m) hose)
0781-2724	HRF 1480-580
0781-2744	HRF 1480-580 (with 10' (3.1 m) hose)

*Outlet Connection: 5/8"-18 RH(F), CS = Clamshell Package*

## TPR 250 Purging Regulator

Light Duty

### Design/Construction

- Single stage design
- Forged brass body and housing cap
- 2 in. (50.8 mm) gauges
- Stem type seat mechanism
- Neoprene diaphragm



Specifications		
<b>Maximum Inlet</b>	<b>Dimensions L x W x H</b>	<b>Weight</b>
3000 psig	4.25 x 6.38 x 5.1 in. (108 x 162 x 130.3 mm)	2 lb 15 oz (1.33 kg)

Ordering Information		
<b>Part No.</b>	<b>Model No.</b>	<b>Delivery Pressure (psig)</b>
0781-9133	TPR 250-125-580 CS	5-125
0781-9127	TPR 250-125-320	5-125
0781-9134	TPR 250-200-580 CS	10-250
0781-9135	TPR 250-500-580 CS	10-250

*Outlet Connection: 1/4"-37" flare, CS = Clamshell Package*

## MECO High Pressure

### Design/Construction

- Single-stage design
- Heavy-duty applications such as oil/gas industry
- Stainless steel diaphragm
- Positive pressure yoke type regulator
- Multi-seat 4 way seat block
- Available as a preset model or with adjusting T-screw



Specifications	
<b>Maximum Inlet</b>	<b>Weight</b>
5500 psig	4 lb 9 oz (2.2 kg)

Ordering Information				
<b>Part No.</b>	<b>Description</b>	<b>Adjusting Mechanism</b>	<b>Pressure</b>	<b>Inlet</b>
5641-8461	P Regulator 125 psi	Cap nut	125	1/4 -18 NPT
5641-8464	P Regulator 150 psi	T screw	150	1/4 -18 NPT
5641-8465	P Regulator 150 psi	Cap nut	150	1/4 -18 NPT
5641-8470	P Regulator 225 psi	T screw	225	1/4 -18 NPT
5641-8468	P Regulator 225 psi	T screw	225	1/4 -18 NPT

## Handles & Cutting Attachments

Design and Construction Features

Model 315FC (Illustrated)

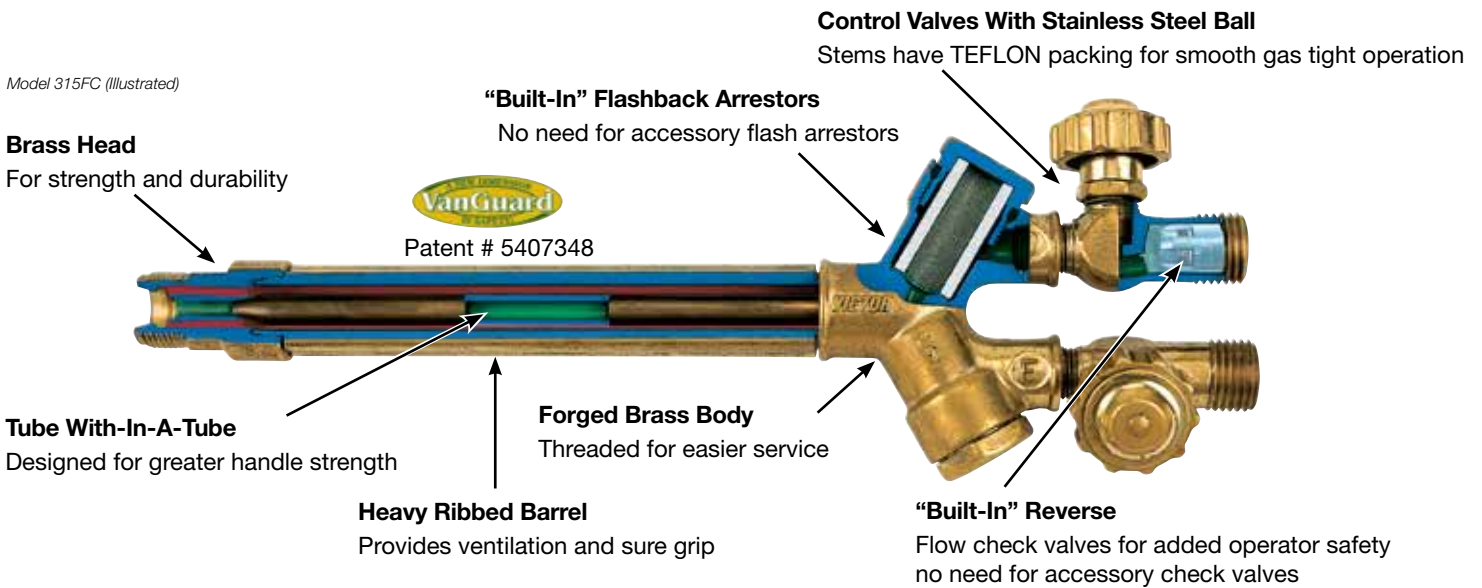

### Rugged, Efficient Design - Threaded Assembly for Ease of Service

#### VICTOR TORCH HANDLES GIVE YOU TWICE THE VALUE

Each torch handle is designed and built to withstand rugged job site conditions. In case of damage, Victor's threaded assembly design lets you replace parts quickly and economically.

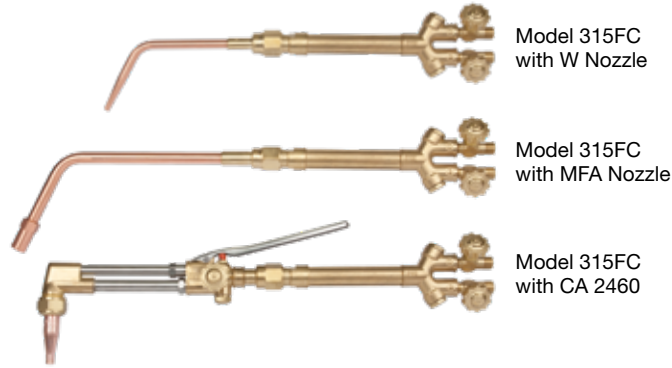

#### PERFORMANCE PROVEN TUBE-WITHIN-A-TUBE DESIGN

Victor torch handles include one oxygen tube within a massive, heavy ribbed handle which also serves as the gas tube. The result is greater strength and durability plus a reduction in overall size and weight for ease of operation.

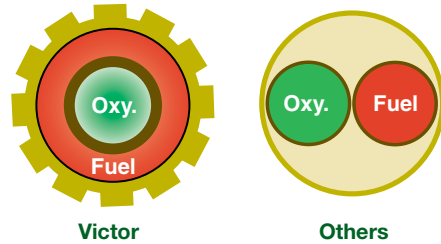

**VICTOR WITHIN-DESIGN**

**TUBE-A-TUBE**

Victor torch handles have greater wall thickness than other designs.

### Compact Balanced Attachments:

For cutting or heating. Each torch handle is designed for optimal balance and feel with its own nozzles and attachments. With proper balance of length and weight, operator fatigue is minimized.

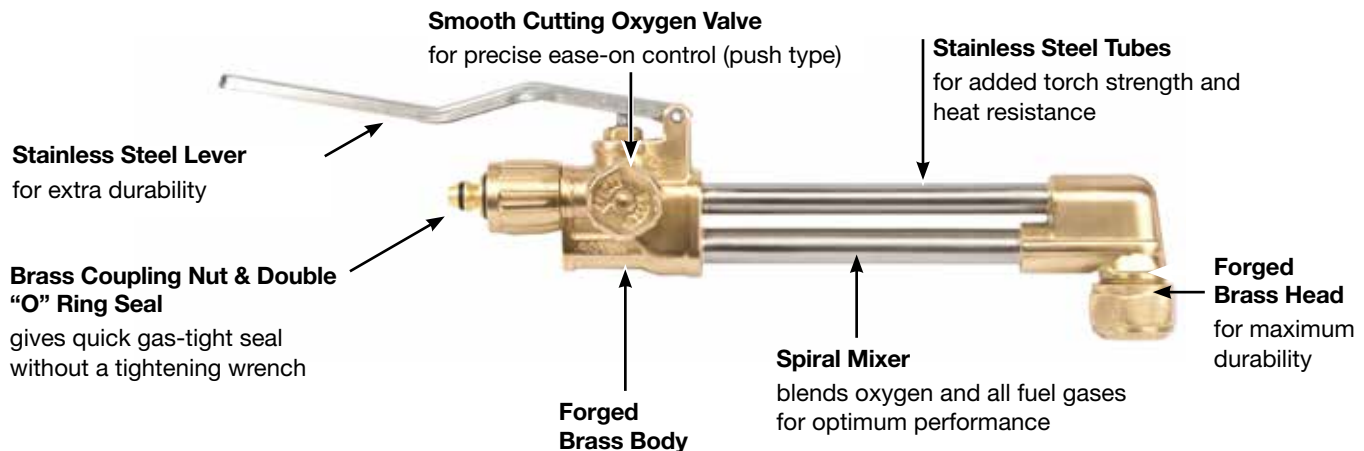

## 400 Series WH 411C Torch Handle

Heavy-duty



- Accepts CA411-3 & CA411-1 Cutting Attachments, W Series Welding Tips and MFA/MFN/Type55 Heating Assemblies
- 5 Year Warranty

### Special designed alloy material:

- 3x the tensile strength of Brass
- Ergonomic, textured, precision contoured handle is designed to reduce operator fatigue and provide better grip
- Durable to withstand tough use and prevention of dents and scratches

### Intuitive knobs:

- Color-coded
- Clearly marked lettering with increase/decrease label
- Understandable in any language

### Ordering Information

Part No.	Model No.	Hose Connection	Gas
0382-0355	WH 411C	"B" 9/16"-18 (CGA 022 & 023)	All

## CA 411-1 Cutting Attachment

Heavy-duty

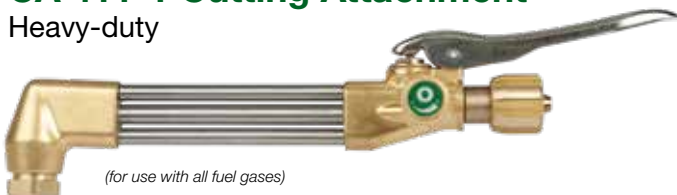

(for use with all fuel gases)

## CA 411-3 Cutting Attachment

Medium-duty



(for use with all fuel gases with appropriate tip)

### Performance matched for each torch handle series.

- Efficient Universal Spiral Head Mixer
- 1 Cutting Attachment for All Fuel Gases
- Redesigned inlet nut increases grip for Hand Tightening
- Inline stainless tubes for better visibility
- Improved Stainless Lever provides increased comfort and reduced operator hand fatigue
- 5 Year Warranty

### Ordering Information

Part No.	Model No.	Cutting Range	Tip Series	Head Angle
0381-1940	CA411-1	6 in. (152.4 mm)	1	90°
0381-1939	CA411-3	5 in. (127.0 mm)	3	90°

Heavy and medium duty cutting attachments for use with acetylene, propane, butane, liquid air fuel gas, natural gas (2 PSI & above) and propylene. Cutting attachment accepts all Victor Style Tips.

## 300 Series HD 310C Torch Handle

Victor heavy industry



Built tough to withstand rugged job site conditions. Threaded assembly permits economical repair if service is necessary. The HD 310C has "B" hose connections with built-in reverse flow check valves for added safety.

The HD 310C is compatible with high capacity heating nozzles and all Victor 300 Series equipment.

### Welding & Cutting Equipment:

- MFA & MFN heating nozzles
- Type 55 high capacity heating nozzles
- CA 2460 cutting attachment
- W Series welding nozzles

### Ordering Information

Part No.	Model No.	Hose Connection	Gas	Weight	Length
0382-0015	HD 310C	"B" 9/16"-18 (CGA 022 & 023)	All	28 oz	11 in. (279.4 mm)

### WARNING: USE FLASHBACK ARRESTORS

Although built to Victor's quality and safety standards, due to the flow capacity requirements, flashback arrestors are not manufactured into this Victor heavy industry torch handle. To reduce the risk of personal injury, death and/or property damage, use sufficient capacity flashback arrestors with all Victor heavy industry torch products.

### Recommended For Best Performance:

#### Flashback Arrestors

Part No.	Model	Type
<b>Oxygen: (Select one of the following)</b>		
0657-0010	*FB-0	Torch Mount
0657-0014	FB-OR	Regulator Mount
<b>Fuel: (Select one of the following)</b>		
0657-0011	*FB-F	Torch Mount
0657-0015	FB-FR	Regulator Mount
<b>Pair Packs</b>		
0656-0001	*FB-1	Oxy/Fuel Torch Mount
0656-0004	FBR-1	Oxy/Fuel Regulator Mount

\*Torch mount models also protect the hose.

### 300 Series WH 315FC+ Torch Handle

Heavy-duty



- Improved head durability, preheat control valve flow and reduced user fatigue due to improved balance
- Improved access and reparability of mixer with single nut removal
- No wrench flats on connection nut indicates hand tightening only for safer operation
- Internal connection snap ring prevents coupling nut sliding and exposure to o-rings for reduced damage
- Use with CA 2460+ cutting attachment

### 100 Series 100FC Torch Handle

Medium-duty



**Victor torch handles are available with VanGuard™ safety features:**

- Built-in flashback arrestors - no need for accessory flash arrestors
- Built-in reverse flow check valves - no need for accessory check valves
- Works with all fuel gases (pressure restrictions for different gases)

#### Ordering Information

WH 315FC+ Welding Handle	0382-0093
Plus Torch Replacement Pack - WH 315FC+/CA 2460+ 90 deg	0381-1937

#### Ordering Information

Part No.	Description	Hose Connection	Gas	Weight	Length
0382-0032	"VanGuard" Medium Duty	9/16 in.-18	All	14 oz	8.5 in. (215.9 mm)
0387-0011	"VanGuard" Medium Duty (Clamshell)	9/16"-18	All	14 oz	8.5 in. (215.9 mm)

VanGuard torch handles are offered in extra heavy duty (H 315FC) and medium duty (100FC) models, and available in Victor's most popular system models. VanGuard torch handles also feature Victor traditional threaded assemblies for economical repair if service is necessary.

### J Series - J-28 & J-40 Torch Handles

Light-duty

Victor torch handles cover the full range of welding, cutting and heating needs. Choose from patented standard models. Performance matched cutting attachments are available for each torch handle series.

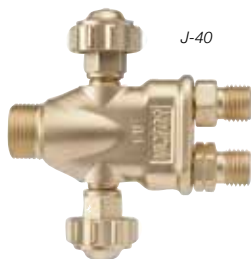

J-28



#### Ordering Information

Part No.	Model No.	Description	Hose Connection	Gas	Weight	Length
0382-0006	J-40	Standard, Light-Duty	"A" Hose CGA 021/022	All	5.5 oz	3.75 in. (95.3 mm)
0382-0127	J-28	Light-Duty	"A" Hose CGA 021/022	All	8.5 oz	6 in. (152.4 mm)

J-40 handle does not have check valves or flashback arrestors included. J-28 handle includes accessory reverse flow check valves for regulator use

## CA 2460+ Cutting Attachment

Heavy-duty



- Improved head durability, preheat control valve flow and reduced user fatigue due to improved balance
- Improved access and reparability of mixer with single nut removal
- Superior cutting oxygen valve with improved Feathering/Ease-On control
- No wrench flats on connection nut indicates hand tightening only for safer operation
- Internal connection snap ring prevents coupling nut sliding and exposure to o-rings for reduced damage
- Use with WH 315FC+ torch handle

Ordering Information	
CA 2460+ Cutting Attachment, 90 Deg	0381-1928
CA 2460+ Cutting Attachment, 75 Deg	0381-1930
CA 2460+ Cutting Attachment, 180 Deg	0381-1932
Plus Torch Replacement Pack - WH 315FC+/CA 2460+ 90 deg	0381-1937

## CA 1350 Cutting Attachment

Medium-duty



(for use with all fuel gases with appropriate tip)

### Performance matched for each torch handle series.

- Forged brass head
- Spiral mixer blends oxygen and fuel
- Smooth cutting valve (pull type)
- Stainless steel tubes
- Brass coupling nut and double "O" ring seal gives quick gas-tight seal tightening with out wrench
- Length 8 in. (203.2 mm)
- Weight 13 oz (0.37 kg)

Ordering Information				
Part No.	Model No.	Cutting Range	Tip Series	Head Angle
0381-0418	CA 1350	6" (152.4 mm)	3	90°
0387-0005	CA 1350 CS	6" (152.4 mm)	3	90°
0381-0420	CA 1351	6" (152.4 mm)	3	75°
0381-0421	CA 1352	6" (152.4 mm)	3	180°

CS = Clamshell Package

HANDLES & ATTACHMENTS

## CA 1260 Cutting Attachment

Light-duty



(for use with all fuel gases with appropriate tip)

### Performance matched for each torch handle series.

- Forged brass head
- Spiral mixer blends oxygen & fuel
- Smooth cutting valve (pull type)
- Stainless steel tubes
- Brass coupling nut & double "O" ring seal gives quick gas-tight seal tightening without wrench
- Length 8 in. (203.2 mm)
- Weight 13 oz (0.37 kg)

Ordering Information				
Part No.	Model No.	Cutting Range	Tip Series	Head Angle
0381-0162	CA 1260	3" (76.2 mm)	3	90°
0387-0003	CA 1260 CS	3" (76.2 mm)	3	90°

CS = Clamshell Package

Exclusive "OPTIMIZED" nozzles with a large choice of types and sizes, plus uniformity of tip orifice and size for all series

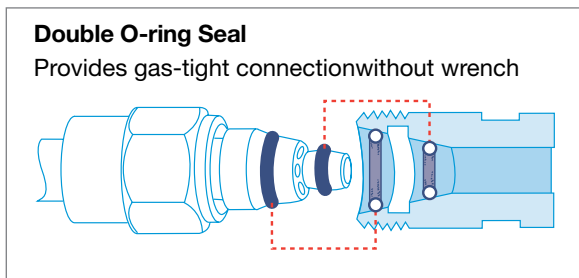
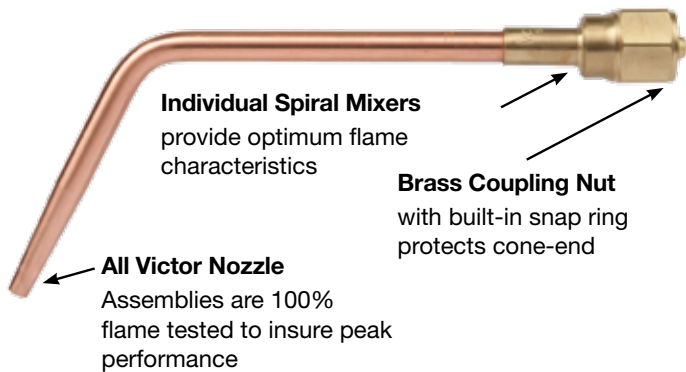

Victor offers a complete range of nozzles, tips and elbows with a size for every application including: welding, brazing, heating, descaling, hard facing, flame priming, etc.

**Nozzles Designed for "Optimum" Performance**

Each complete nozzle has its own built-in spiral mixer, individually designed for each tip size and flame characteristic. Each nozzle is individually swaged to insure proper alignment for uniform flame, sizing and free-flow contour.

**Orifice Sizes are Common for All Series**

Regardless of nozzle series (W, W-1, W-J), flame characteristic or fuel gas used. The uniformity of orifice sizes simplifies nozzle selection, eliminates chances of ordering and wrong size when changing from one type of nozzle to another.

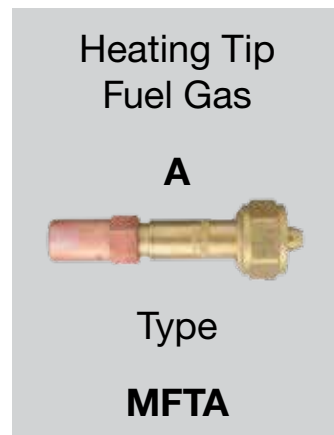

NOZZLES

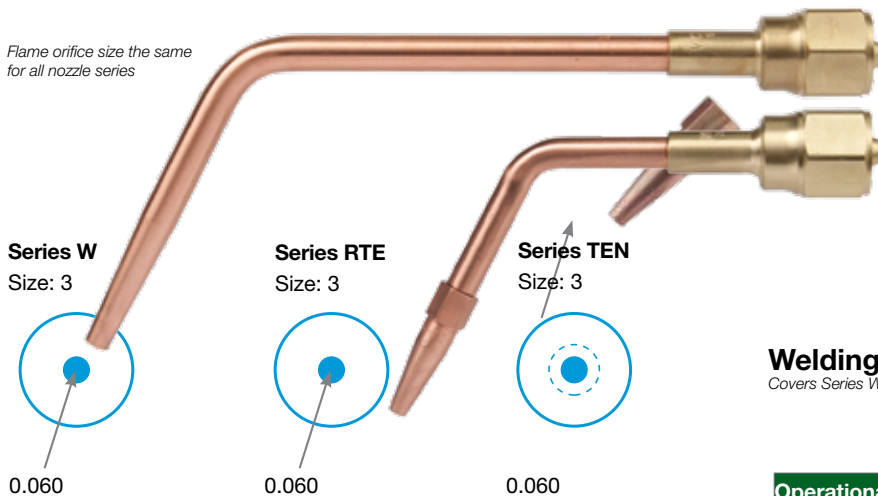

**Welding Nozzle Operational Data/Acetylene**

Covers Series W (Heavy Duty), W-1 (Medium Duty) And W-J (Light Duty) Series

Oxy-Acetylene & Oxy-Hydrogen				
Application	Torch Series	Nozzle Type	Available Sizes	Illustration
General purpose welding & heating. Uses replaceable tip ends. Flame characteristic – Long cone	315FC H 315FC	RTE	000-6, 8, 10	65°  Sizes: 000-6, 8 (Length 4.5") Size: 10 (Length 14")
General purpose welding & preheating. Swaged one-piece copper elbow. Flame characteristic – Long cone	315FC 100FC	W W-1	000-8, 10 000-7	65°  Sizes: 000-8 (Length 4.5") Size: 10 (Length 14")
	J-28 J-40	W-J	000-4	

Operational & Performance Data					
Metal Thickness	Tip Size	Drill Size	Oxygen (psig)	Acetylene (psig)	Acetylene (Scfh)
1/32" (0.8 mm)	000	75 (0.022)	3/5	3/5	1/2
3/64" (1.2 mm)	00	70 (0.028)	3/5	3/5	1.5/3
5/64" (1.9 mm)	0	65 (0.035)	3/5	3/5	2/4
3/32" (2.4 mm)	1	60 (0.040)	3/5	3/5	3/6
1/8" (3.2 mm)	2	56 (0.046)	3/5	3/5	5/10
3/16" (4.8 mm)	3	53 (0.060)	4/7	3/6	8/18
1/4" (6.4 mm)	4	49 (0.073)	5/10	4/7	10/25
1/2" (12.7 mm)	5	43 (0.089)	6/12	5/8	15/35
3/4" (19.0 mm)	6	36 (0.106)	7/14	6/9	25/45
1 1/4" (32.0 mm)	7	30 (0.128)	8/16	8/10	30/60
2" (51.0 mm)	8	29 (0.136)	10/19	9/12	35/75
3" (76.2 mm)	10	27 (0.144)	12/24	12/15	50/100

WARNING: At no time should the withdrawal rate of an individual acetylene cylinder exceed 1/7 of the cylinder contents per hour. If additional flow capacity is required use an acetylene manifold system of sufficient size to supply the necessary volume.

Oxygen consumption (SCFH) is 1.1 times the acetylene under neutral flame conditions.



## Type 55/55-1 Multi-Flame Heating Nozzles

Use with 300, HD 310C Series Torch Handles  
Victor Heavy Industry

The Type 55 Series multi-flame heating nozzles feature a raised center point on the head to prevent bumping the plate and compressing the flame. The center point and improved mixer design combine to provide greater resistance to sustained backfire and improved flow performance. Type 55s can be ordered as a complete assembly or as individual components.

- High capacity heating head for heat treating, straightening, and priming
- LP Gases

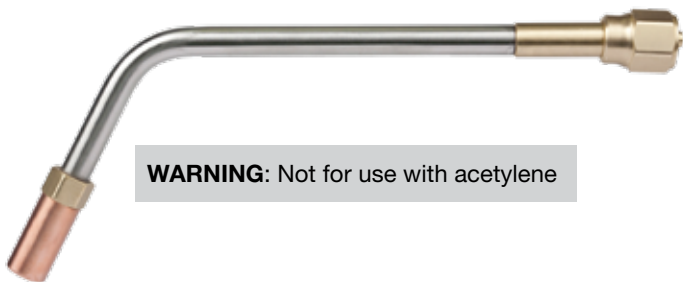

**WARNING:** Not for use with acetylene

Ordering Information				
Part No.	Type	Available size	Available Length	Series
0323-0326	55	20*	28 in. (711.2 mm)	HD 310C
0323-0325	55	15*	28 in. (711.2 mm)	HD 310C
0323-0324	55	10*	28 in. (711.2 mm)	HD 310C
0323-0328	55	8	11 in. (279.4 mm)	HD 310C/300
0323-0327	55	6	11 in. (279.4 mm)	300
0324-0188	55-1	6	11 in. (279.4 mm)	100

\*Size 10, 15 and 20 Type 55 heating nozzles must be used with HD 310C torch handle and 3/8" (9.5 mm) hose.

### Type 55 – for use with Propylene based fuel gases, Methane, Propane, Butane, & pressurized Natural Gas

Tip Size	Oxygen Pressure (psig)	Fuel Pressure (psig)	Oxygen Consumption (SCFH)	Fuel Consumption (SCFH)	BTU/h
20	100/150	30/50	900/1150	400/500	See Chart
15	90/120	20/35	600/800	250/350	
10	70/100	15/25	356/460	150/200	
8	70/85	15/25	220	85	
6	70/80	15/20	160	65	

### BTU Per Hour

To approximate gross BTU output, multiply flow rate by BTU value listed below:

Propane	2498
Natural Gas	1000
Butane	3374
Propylene	2371

### Warning:

- Use flashback arrestors
- Although built to Victor's quality and safety standards, due to the cutting capacity and/or design of each torch, flashback arrestors are not manufactured into the 310C Series Victor heavy industry torches
- To reduce the risk of personal injury, death and/or property damage, use sufficient capacity flashback arrestors with all Victor heavy industry torch products
- Alternative fuel gas only refers to propane, natural gas, propylene gases. Acetylene, hydrogen and gasoline are NOT included as an alternative gas

## Type 55 Components

### 300 Series

Type 55 Series multi-flames are available as components. Threaded elbows give you the flexibility to easily service or extend the length of the nozzles. Use the special extensions adapter to extend the tip tube to the required length.



**0328-0012 & 0328-0013**  
Mixer and Nut Assembly

Ordering Information					
Part No.	Available Size	Application/Description	Available Length	Available Angles	Series
0311-0232	20*	Multi-Flame Heads	–	–	HD 310C
0311-0231	15*	Multi-Flame Heads	–	–	HD 310C
0311-0230	10*	Multi-Flame Heads	–	–	HD 310C
0311-0241	8	Multi-Flame Heads	–	–	HD 310C/300
0311-0240	6	Multi-Flame Heads	–	–	300
0304-0002	–	Multi-Flame Elbows	14" (355.6 mm)	65°	HD 310C/300
0304-0095	–	Multi-Flame Elbows	16" (406.4 mm)	180°	HD 310C/300
0304-0011	–	Multi-Flame Elbows	26" (660.4 mm)	65°	HD 310C/300
0328-0012	Mixer and nut assembly, for use with pressures from 10 psig and up.				HD 310C/300
0328-0013	Mixer and nut assembly, for use with pressures from 2 - 10 psig.				HD 310C/300
0312-0064	Extension Adapter - Thread specifications: 1/4"- 18 NPT(F) X 1/2"- 27 UNS(F)"				HD 310C/300

\*Size 10, 15 and 20 Type 55 heating nozzles must be used with HD 310C torch handle and 3/8" (9.5 mm) hose.

## MFN/MFN-1 Heating Nozzles

Use with 100, 300 & HD310C Series Torch Handles  
Victor Heavy Industry

- Multi-flame heating head for preheating, priming and straightening
- LP Gases

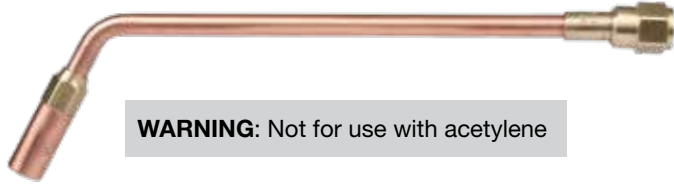

**WARNING:** Not for use with acetylene

Ordering Information					
Part No.	Type	Size	Tip End Replacement	Length	Series
0323-0303	MFN	12*	–	17.5" (444.5 mm)	HD 310C
0323-0304	MFN	15*	–	17.5" (444.5 mm)	HD 310C
0323-0305	MFN	20*	–	17.5" (444.5 mm)	HD 310C
0323-0292	MFN	8	–	12.0" (304.8 mm)	300
0323-0302	MFN	10	–	17.5" (444.5 mm)	300
0324-0117	MFN-1	6	0311-0611	12.0" (304.8 mm)	100
0324-0118	MFN-1	8	0311-0612	12.0" (304.8 mm)	100

\*Size 12, 15 and 20 MFN heating nozzles must be used with HD 310C torch handle and 3/8" (9.5 mm) hose.

### Type MFN, MFN-1 – for use with Propane & Natural Gas

Tip Size	Oxygen Pressure (psig)	Fuel Pressure (psig)	Oxygen Consumption (SCFH)	Fuel Consumption (SCFH)	BTU Per Hour
6	8/20	2/10	20/80	5.5/20	See Chart
8	10/20	10/15	40/140	10/35	
10	10/30	12/20	80/320	20/80	
12	30/125	15/25	120/640	30/160	
15	30/125	15/25	200/800	50/200	
20	40/135	15/25	300/1000	75/250	

### BTU Per Hour

To approximate gross BTU output, multiply flow rate by BTU value listed below:

Propane	2498
Natural Gas	1000
Butane	3374
Propylene	2371

### Warning:

- Use flashback arrestors
- Although built to Victor's quality and safety standards, due to the cutting capacity and/or design of each torch, flashback arrestors are not manufactured into the 310C Series Victor heavy industry torches
- To reduce the risk of personal injury, death and/or property damage, use sufficient capacity flashback arrestors with all Victor heavy industry torch products
- Alternative fuel gas only refers to propane, natural gas, propylene gases. Acetylene, hydrogen and gasoline are NOT included as an alternative gas

## MFA/MFA-1 Heating Nozzles

Use with J, 100, 300 & HD310C Series Torch Handles  
Victor Heavy Industry

- Multi-flame heating head for heat treating, straightening and priming
- Acetylene / Hydrogen



Ordering Information						
Part No. Boxed	Part No. Clamshell	Type	Size	Tip End Replacement	Length	Series
0323-0261	0387-0064	MFA	12	0311-0540	17.5" (444.5 mm)	HD 310C
0323-0262	0387-0065	MFA	15	–	17.5" (444.5 mm)	HD 310C
0323-0250	0387-0060	MFA	4	0311-0536	12.0" (304.8 mm)	300
0323-0251	0387-0061	MFA	6	0311-0537	12.0" (304.8 mm)	300
0323-0252	0387-0062	MFA	8	0311-0538	12.0" (304.8 mm)	300
0323-0260	0387-0063	MFA	10	0311-0539*	12.0" (304.8 mm)	300
0324-0108	–	MFA-1	2	0311-0598	12.0" (304.8 mm)	100
0324-0109	0387-0071	MFA-1	4	0311-0599	12.0" (304.8 mm)	100
0324-0110	0387-0072	MFA-1	6	0311-0600	12.0" (304.8 mm)	100
0324-0111	0387-0073	MFA-1	8	0311-0601	12.0" (304.8 mm)	100
0325-0104	–	MFA-J	2	–	–	J
0325-0105	–	MFA-J	4	–	–	J
0325-0106	0387-0077	MFA-J	6	–	–	J

\*Size 12, 20 and MFA heating nozzles must be used with HD 310C torch handle and 3/8" (9.5 mm) hose.

### Type MFA, MFA-1 – for use with Acetylene

Tip Size	Oxygen Pressure (psig)	Acetylene Pressure (psig)	Oxygen Consumption (SCFH)	Acetylene Consumption (SCFH)	BTU Per Hour
2	4/8	4/8	3/10	3/9	See Chart
4	8/12	6/10	7/22	6/20	
6	10/15	8/12	15/44	14/40	
8	20/30	10/15	33/88	30/80	
10	30/40	12/15	44/110	40/100	
12	50/60	12/15	66/165	60/150	
15	50/60	12/15	99/244	90/220	

### BTU Per Hour

To approximate gross BTU output, multiply flow rate by BTU value listed below:

Acetylene	1470
Methane	1000

### Warning:

At no time should the withdrawal rate of an individual acetylene cylinder exceed 1/7 of the cylinder contents per hour. If additional flow capacity is required use an acetylene manifold system of sufficient size to supply the necessary volume.

## Series 1 Heating Tips Type MFTA – Acetylene



For preheating before welding, descaling and paint burning, etc.



### Ordering Information

Size	Part No.
6	0330-0527
8	0330-0528
*10	0330-0523
*12	0330-0524

*\*Use 3/8" (9.5 m) hose and straight torch  
Required pressures: 12/15 Acetylene; 70/80 psig Oxygen  
Size 8 is maximum size for use with cutting attachments*

## Type MFTN – LP (Propane/Natural Gas)



For preheating before welding, descaling and paint burning, etc.



### Ordering Information

Size	Part No.
10	0330-0521
12	0330-0522

*Not for use with cutting attachments*

## CHT Adaptor

- Concentrated Heating Tip Adaptor for straightening, bending and forming of plate
- For Use with Alternate Fuels
- Use with HPP or HPN size 5 cutting tip, multi-flame elbow, or mixer and nut assembly



### Ordering Information

CHT Adaptor	0312-0089
-------------	-----------

## Welding Nozzles W Series

For use with  
300 Series torch handles



### W-1 Series

For use with  
100 Series torch handles



### W-J Series

For use with  
J Series torch handles



- General purpose welding & preheating
- Fuel gas usage - acetylene, hydrogen
- 65° tip angle
- Long cone flame
- One piece copper elbow tip

### Ordering Information

Model	Size	Part No.		Series
		Boxed	Clamshell	
W	000	0323-0110	–	300
	00	0323-0111	0387-0019	300
	0	0323-0112	0387-0020	300
	1	0323-0120	0387-0021	300
	2	0323-0121	0387-0022	300
	3	0323-0122	0387-0023	300
	4	0323-0130	0387-0024	300
	5	0323-0131	–	300
	6	0323-0132	–	300
	7	0323-0140	–	300
W-1	000	0324-0068	0387-0028	100
	00	0324-0069	0387-0029	100
	0	0324-0070	0387-0030	100
	1	0324-0071	0387-0031	100
	2	0324-0072	0387-0032	100
	3	0324-0073	0387-0033	100
	4	0324-0074	0387-0034	100
	5	0324-0075	–	100
	6	0324-0076	–	100
	W-J	000	0325-0081	–
00		0325-0082	0387-0039	J
0		0325-0083	0387-0040	J
1		0325-0084	0387-0041	J
2		0325-0085	0387-0042	J
3		0325-0086	0387-0043	J
5		0325-0088	–	J
6		0325-0089	–	J
7	0325-0090	–	J	

## Elbow Tips

### ET Series

For use with  
300 Series torch handles



### ET-1 Series

For use with  
100 Series torch handles



### ET-J Series

For use with  
J Series torch handles



- One piece copper elbow tip
- Long cone flame
- Fuel gas usage - acetylene, hydrogen

Ordering Information			
Model	Size	Part No.	Series
ET	000	0311-0055	300
	00	0311-0056	300
	0	0311-0057	300
	1	0311-0058	300
	2	0311-0059	300
	3	0311-0572	300
	4	0311-0573	300
	5	0311-0574	300
	6	0311-0575	300
	7	0311-0576	300
ET-1	3	0311-0345	100
	4	0311-0340	100
	5	0311-0602	100
	6	0311-0603	100
	ET-J	000	0311-0123
00		0311-0124	J
0		0311-0125	J
1		0311-0126	J
2		0311-0127	J
3		0311-0128	J
4	0311-0129	J	

## UM Series Universal Mixers

Oxy-Acetylene universal mixers used when exact performance & Individual nozzles are not needed.



Ordering Information					
Type	Part No.	Fuel Gas Usage	Elbow Tips	Length	Series
4-UM-1	0328-0005	Oxy-Acetylene	000-2 ET, 3 ET-1, 4 ET-1	1.75" (44.5 mm)	100
7-UM-1	0328-0009	Oxy-Acetylene	5 ET-1, 6 ET-1	1.75" (44.5 mm)	100

## RTE Series Replaceable Tip Ends

For use with 300 Series torch handles

- General purpose welding & preheating
- Uses replacement tip ends (TE Series)
- 65° tip angle



## RTEN Series

- General purpose brazing & preheating
- Long cone flame
- Uses TEN tip ends

Ordering Information				
Model	Size	Part No.	Fuel Gas Usage	Series
RTE	00	0323-0307	Acetylene, Hydrogen	300
	0	0323-0308	Acetylene, Hydrogen	300
	1	0323-0309	Acetylene, Hydrogen	300
	2	0323-0310	Acetylene, Hydrogen	300
	3	0323-0311	Acetylene, Hydrogen	300
	4	0323-0312	Acetylene, Hydrogen	300
	5	0323-0313	Acetylene, Hydrogen	300
	6	0323-0314	Acetylene, Hydrogen	300
	8	0323-0316	Acetylene, Hydrogen	300
	10	0323-0317	Acetylene, Hydrogen	300
RTEN	6	0323-0284	Natural Gas, Propane	300

## FE Series Flexible Elbow

- Flexible elbow for special welding, brazing, and heating needs
- Multi-fuel gas service
- Uses replaceable tip ends
- Thread: 5/16"-27



Ordering Information					
Type	Part No.	Fuel Gas Usage	Tip End Replacements	Length	Series
FE	0323-0191	Multi-Gas Fuel Service	TE, TEN, TEMFA, TEMFN, TEMF	11.5 in. (292.1 mm)	300
FE-1	0324-0066	Multi-Gas Fuel Service	TE, TEN, TEMFA, TEMFN, TEMF	11.5 in. (292.1 mm)	100
FE-J	0325-0102	Multi-Gas Fuel Service	TE, TEN, TEMFA, TEMFN, TEMF	11.5 in. (292.1 mm)	J

## UN Series Universal Nozzle

- Standard bend nozzle for welding, brazing and heating
- Uses replaceable tip ends
- 65° tip angle
- Thread: 5/16"-27



Ordering Information					
Type	Part No.	Fuel Gas Usage	Tip End Replacements	Length	Series
UN	0323-0242	Multi-Gas Fuel Service	TE, TEN, TEMFA, TEMFN, TEMF	5 in. (127.0 mm)	300
UN-1	0324-0094	Multi-Gas Fuel Service	TE, TEN, TEMFA, TEMFN, TEMF	5 in. (127.0 mm)	100
UN-J	0325-0101	Multi-Gas Fuel Service	TE, TEN, TEMFA, TEMFN, TEMF	5 in. (127.0 mm)	J

## DFE Series Dual Flexible Elbows

- Dual flexible elbow nozzle assembly for special welding, brazing and heating
- Uses replaceable tip ends
- Thread: 5/16"-27

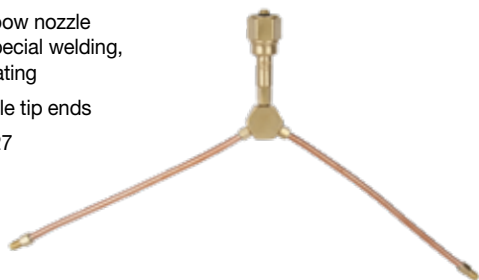

Ordering Information				
Type	Part No.	Fuel Gas Usage	Tip End Replacements	Series
DFE	0323-0192	Multi-Gas Fuel Service	TE, TEN, TEMFA, TEMFN, TEMF	300
DFE-1	0324-0092	Multi-Gas Fuel Service	TE, TEN, TEMFA, TEMFN, TEMF	100
DFE-J	0325-0108	Multi-Gas Fuel Service	TE, TEN, TEMFA, TEMFN, TEMF	J

## Replaceable Tip Ends

TE, TEN, TEMFA, TEMFN & TEMF 300, 100 & J Series

For All Nozzles Using Replaceable Tip Ends			
Type	Application, Description	Fuel Gas	Illustration
TE	Welding, brazing Flame – long Cone One piece	Acetylene	
TEN	Brazing, silver brazing Flame – long Cone One piece	Natural Gas, Propane	
TEMFA	Brazing, silver brazing, heating Flame – multi-flame One piece	Acetylene	
TEMFN	Brazing, silver brazing, heating Flame – multi-flame One piece	All Fuel Gases Except Acetylene	
TEMF	Brazing, soldering, heating Flame – multi-flame Two piece	All Fuel Gases Except Acetylene	

Tip Size, Length, Thread Size				
Type	Size(s)	Length	Thread	Part No.
TE	000	1.5 in. (38.1 mm)	5/16-27	0311-0471
	00	1.5 in. (38.1 mm)	5/16-27	0311-0472
	0	1.5 in. (38.1 mm)	5/16-27	0311-0473
	1	1.5 in. (38.1 mm)	5/16-27	0311-0474
	2	1.5 in. (38.1 mm)	5/16-27	0311-0475
	3	1.63 in. (41.4 mm)	5/16-27	0311-0587
	4	1.88 in. (47.8 mm)	5/16-27	0311-0588
	5	2 in. (50.8 mm)	5/16-27	0311-0589
	6	2.25 in. (57.2 mm)	0.393-27	*0311-0590
	8	2.75" (69.9 mm)	0.393-27	*0311-0592
TEN	10	3" (76.2 mm)	0.440-27	*0311-0593
	0	1.5 in. (38.1 mm)	5/16-27	0311-0483
	2	1.5 in. (38.1 mm)	5/16-27	0311-0485
	3	1.63 in. (41.4 mm)	5/16-27	0311-0486
	4	1.88 in. (47.8 mm)	5/16-27	0311-0487
	5	2 in. (50.8 mm)	5/16"-27	0311-0488
	6	2.25 in. (57.2 mm)	0.393-27	*0311-0585
TEMFA	1	1.5 in. (38.1 mm)	5/16-27	0311-0215
	2	1.5 in. (38.1 mm)	5/16-27	0311-0216
	3	1.5 in. (38.1 mm)	5/16-27	0311-0217
	4	1.5 in. (38.1 mm)	5/16-27	0311-0218
	5	1.5 in. (38.1 mm)	5/16-27	0311-0219
TEMFN	3	1.5 in. (38.1 mm)	5/16-27	0311-0306
	4	1.5 in. (38.1 mm)	5/16-27	0311-0307
	5	1.5 in. (38.1 mm)	5/16-27	0311-0308
TEMF	6	1.5 in. (38.1 mm)	5/16-27	0311-0676
	7	1.5 in. (38.1 mm)	5/16-27	0311-0677
	8	1.5 in. (38.1 mm)	5/16-27	0311-0678
	9	1.5 in. (38.1 mm)	5/16-27	0311-0679
	10	1.5 in. (38.1 mm)	5/16-27	0311-0680

Adapter for tip ends to fit tip tube: 5/16"-27(F) x 1/8"-27(M) 0312-0071 \*Fit nozzles RTE only

## Victor “Universal Torches”

They combine the spiral and injector mixer principles. The result is a high performance torch that operates on any fuel gas.

Universal torch cutting capacity from 1/8 in. (3.2 mm) to 8 in. (203.2 mm).

*Model ST 2600FC Illustrated  
Patent # 5407348*

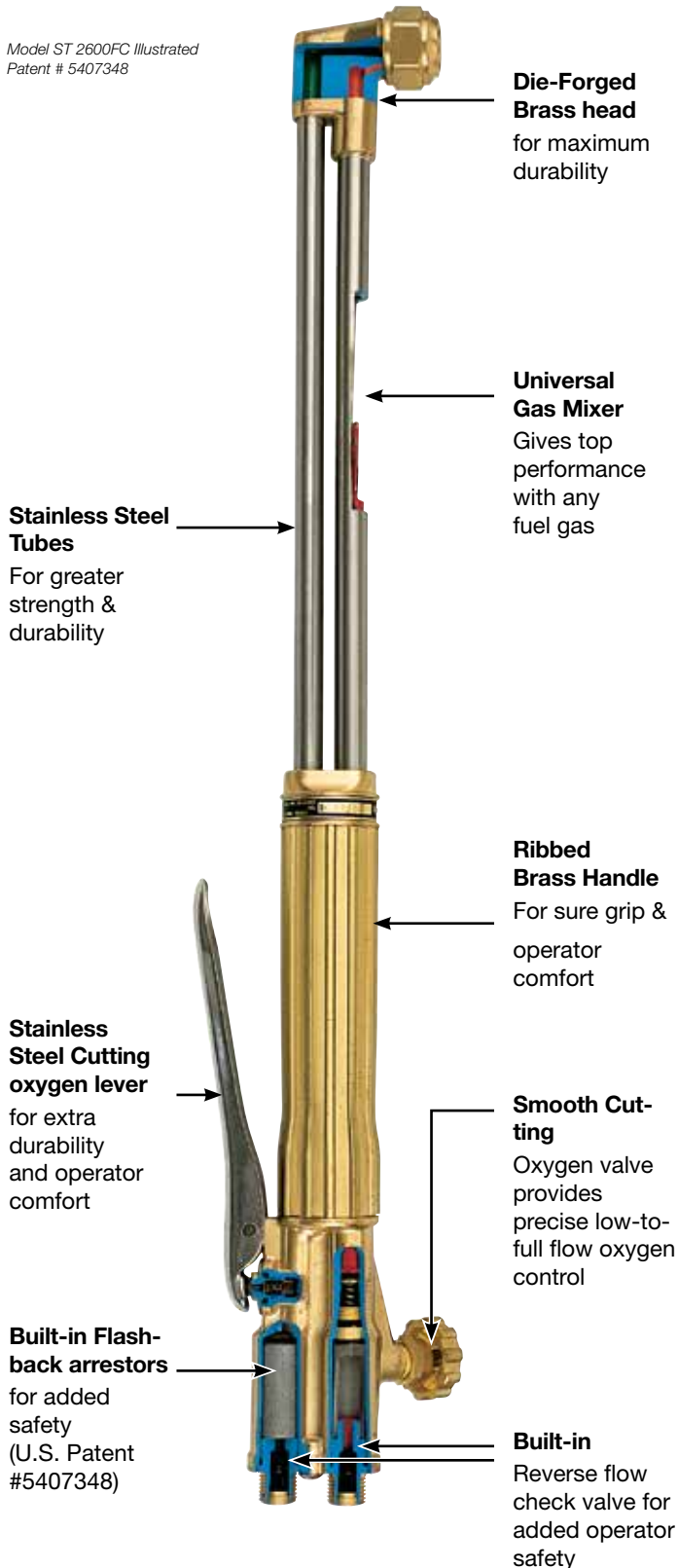

The high capacity straight torches in this section are designed for heavy cutting applications found in such industries as scrapping, demolition and foundries.

Although built to Victor’s quality and safety standards, due to the cutting capacity and/or design of each torch, flashback arrestors are not manufactured into these Victor Heavy Industry torches.

**WARNING:** Use add-on flashback arrestors

To reduce the risk of personal injury, death and/or property damage, use sufficient capacity flashback arrestors with all Victor Heavy Industry torch products.

Alternative fuel gas only refers to propane, natural gas, propylene gases. **Acetylene, hydrogen and gasoline** are **NOT** included as an alternative gas.

**Do you need special length torches?  
If you don't see what you need contact  
Technical Services**

**1-800-569-0547**

**Reference Heavy Industry Products**  
Victor welcomes your request for special length torches.

**Built-in Reverse flow check valve**  
for added operator safety

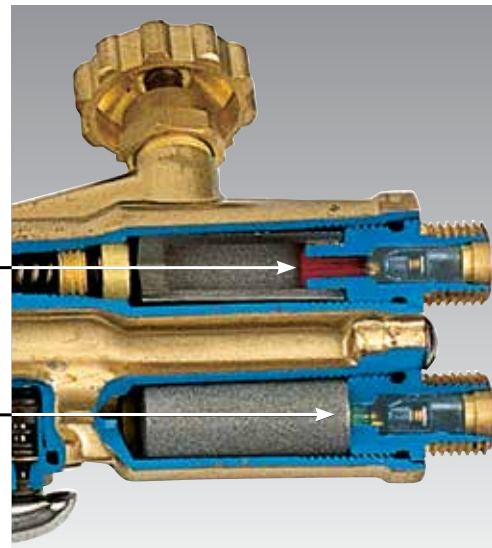

**Most Victor Hand Cutting Torches**  
are equipped with built-in reverse flow check valves and flash arrestors

## HC 1500C

Victor heavy industry

### Three hose scrap straight cutting torches



The HC 1500C Series is a three hose design with a 48 in. cutting capacity and is ideal for heavy steel, scrap cutting. The torch has "C" 7/16"-14 (RH) oxygen connection and standard "B" 9/16"-18 oxygen/fuel preheat connections.

The HC 1500C is manufactured without built-in flashback arrestors. Reverse flow check valves are installed at the inlet connection.

- Three hose connection
- Extra heavy-duty
- Cutting capacity 48 in. (121.9 cm)
- Length: 56 in. (142.2 cm)
- For use with propane or natural gas
- Not for use with acetylene
- Uses Series 2-285N (two piece) cutting tips
- Special lengths available on request

**WARNING:** Use add-on flashback arrestors.  
Not for use with acetylene.

#### Ordering Information

Part No.	Model No.	Head Angle	Hose Connection Preheat	Hose Connection Cutting (Oxygen)	Length	Fuel Gas	Cutting Capacity
0381-0444	HC 1500C	180°	"B" 9/16" -18 LH & RH	"C" 7/8 in. -14 RH	48 in. (121.9 cm)	Natural Gas & Propane	48 in. (121.9 cm)
0381-0509	HC 1500C	90°	"B" 9/16" -18 LH & RH	"C" 7/8 in. -14 RH	84 in. (213.4 cm)	Natural Gas & Propane	48 in. (121.9 cm)
0381-0515	HC 1500C	90°	"B" 9/16" -18 LH & RH	"C" 7/8 in. -14 RH	96 in. (243.8 cm)	Natural Gas & Propane	48 in. (121.9 cm)

*Uses Series 2-285N (two piece) cutting tips. See chart below*

**For best performance, use the following recommended equipment:**

#### Flashback Arrestors

Gas Service	Part No.	Model	Type
Cutting Oxygen	Not required		
Preheat Oxygen	0657-0076	*FBHC-O	Torch Mount
	0657-0078	FBHC-OR	Regulator Mount

*\*Torch mount models also protect the hose*

#### Hoses

(Contact local distributor for hose information)

- Cutting Oxygen:
  - 1/2" I.D. with "C" hose (7/16"-14 RH) connections
  - Use T-grade or RM-grade hose
- Preheat Oxygen:
  - 3/8" I.D. with "B" hose (9/16"-18 RH) connections
  - Use T-grade hose
- Preheat Fuel:
  - 3/8" I.D. with "B" hose (9/16"-18 LH) connections
  - Use T-grade hose

#### Regulators

- Cutting Oxygen:
  - ELC4, ESS4-125-540R, ESS7-125-540, SR 700D- 540, or S or L 700D-500/750 line supply
- Preheat Oxygen:
  - ESS4-125-540, SR 450D-540, or S or L 700D-500/750 line supply
- Preheat Fuel:
  - ESS4-125-510LP, SR 461D-510, or S or L 711D-500/750 line supply

#### 2-285N Two Piece Tips – for use with HC 1500C torches

Part No.	Model No.	Size	Cutting Range	Cutting Orifice Dia.	*Cutting Oxygen (psig)	Cutting Oxygen (SCFH)	Preheat Oxygen (psig)	Preheat Oxygen (SCFH)	*Fuel (psig)	Fuel (SCFH)
0336-0041	2-285N	0.25	14" to 20"	0.25	25/45	1500/2400	25/50	250/400	15/20	60/120
0336-0042	2-285N	0.312	20" to 26"	0.312	25/45	2300/3500	25/50	250/400	15/20	60/120
0336-0043	2-285N	0.375	26" to 34"	0.375	20/40	2300/3900	25/50	250/400	15/20	60/120
0336-0044	2-285N	0.437	34" Over	0.437	20/40	2400/4500	25/50	250/400	15/20	60/120

*\*Pressure is measured at back of torch when torch is flowing*

*Oxygen Consumption:*

*1. Adequate volume required. Dual supplies recommended when using cylinders.*

*2. When operating from bulk oxygen supply it is recommended that separate oxygen drop stations are used.*

## HC 1200C Series

Victor heavy industry

High capacity/heavy-duty



**WARNING:** Use add-on flashback arrestors.  
Not for use with acetylene.

The HC 1200C Series torches are high capacity, heavy duty cutting torches that have a cutting capacity up to 18" (45.7 cm). These torches are used in a wide variety of heavy industrial applications that include scrapping and demolition.

The HC 1200C is manufactured without built-in flashback arrestors. Revers flow check valves are installed at the inlet connection.

- For use with any fuel gas, 2 psig and above
- Universal mixer
- Cutting capacity 18" (45.7 cm)
- Standard Lengths: 21" (53.3 cm) - 96" (243.8 cm)
- Uses Series 1 cutting tips
- "B" 9/16"-18 hose connections
- Extra length models available upon request
- Lock down lever kit available. Part number: 0307-0062

Ordering Information			
Torch Part No.	Model No.	Head Angle	Length
0381-1402	HC 1200C	90°	21 in. (53.3 cm)
0381-1403	HC 1201C	75°	21 in. (53.3 cm)
0381-1404	HC 1202C	180°	21 in. (53.3 cm)
0381-1405	HC 1230C	90°	36 in. (91.4 cm)
0381-1406	HC 1231C	75°	36 in. (91.4 cm)
0381-1407	HC 1232C	180°	36 in. (91.4 cm)
0381-1408	HC 1250C	90°	48 in. (121.9 cm)
0381-1432	HC 1250LC*	90°	48 in. (121.9 cm)
0381-1409	HC 1251C	75°	48 in. (121.9 cm)
0381-1415	HC 1252C	180°	48 in. (121.9 cm)
0381-1419	HC 1262C	180°	60 in. (152.4 cm)
0381-1412	HC 1270C	90°	72 in. (182.9 cm)
0381-1413	HC 1271C	75°	72 in. (182.9 cm)
0381-1414	HC 1272C	180°	72 in. (182.9 cm)
0381-1424	HC 1280C	90°	84 in. (213.4 cm)
0381-1418	HC 1290C	90°	96 in. (243.8 cm)

\*Locking Lever

For best performance, use the following recommended equipment:

### Flashback Arrestors

Gas Service	Part No.	Model	Type	Recommended Tip Size
Oxygen	0657-0010	*FB-O	Torch Mount	Up to size: 8
	0657-0014	FB-OR	Regulator Mount	Up to size: 8
	0657-0076	*FBHC-O	Torch Mount/High Flow	10 and larger
	0657-0078	FBHC-OR	Regulator Mount/High Flow	10 and larger
Fuel	0657-0011	*FB-F	Torch Mount	-
	0657-0015	FB-FR	Regulator Mount	-

\* Torch mount models also protect the hose

### Hoses

(Contact local distributor for hose information)

- Oxygen:
  - 3/8" (9.5 mm) I.D. with "B" hose (9/16"-18 LH) connections
  - Use T-grade hose
- Fuel:
  - 3/8" (9.5 mm) I.D. with "B" hose (9/16"-18 LH) connections
  - Use T-grade hose

### Regulators

- Oxygen:
  - ELC4, ESS4-125-540R, ESS7-125-540, SR 450D- 540 Cylinder, SR 700D-540 cylinder or L 700D/E-500/750 line supply
- Fuel:
  - ESS4-125-510, SR 461D-510 cylinder, SR 711B/C/D-510 or L 711B/C/D-500/750 line supply



## Bulldog™ - HC 1100C

Victor Heavy Industry  
Scrap Straight Cutting Torch



With Bulldog torches, superior performance and productivity are assured. The low profile head and lightweight design, strength and durability put Bulldog in a class by itself.

The HC 1100C is manufactured without built-in flashback arrestors. Revers flow check valves are installed at the inlet connection

- Patented head and mixer
- Bottom rear lever with pin/clip design
- Specially designed 'supercharged' preheat oxygen valve
- Reduces flame blow-off
- Bottom located valves for right or left hand use
- Threaded inlet connections with integral check valve for ease of repair
- Body designed for high flow applications
- 3 heavy duty tube supports for ultra strength and durability on extra length models
- UltraMix low-pressure mixer specially designed for LP gas
- Sleek low profile head with no protrusions to hinder cutting
- For use with propane and natural gas

### Bulldog tips by Victor offer a cost effective alternative for efficient scrap cutting

- For scrap cutting
- Heavy wall - two piece design
- Resists slag build-up
- Available in Victor and Harris® styles

Ordering Information					
Part No.	Model No.	Lever Position	Tip Series	Head Angle	Overall Length
<b>Victor Bulldog with Victor Head</b>					
0381-1703	HC 1100C	Bottom Rear	1	90°	21 in. (53.3 cm)
0381-1704	HC 1101C	Bottom Rear	1	75°	21 in. (53.3 cm)
0381-1709	HC 1130C	Bottom Rear	1	90°	36 in. (91.4 cm)
0381-1710	HC 1131C	Bottom Rear	1	75°	36 in. (91.4 cm)
0381-1711	HC 1132C	Bottom Rear	1	180°	36 in. (91.4 cm)
0381-1712	HC 1150C	Bottom Rear	1	90°	48 in. (121.9 cm)
0381-1713	HC 1151C	Bottom Rear	1	75°	48 in. (121.9 cm)
0381-1714	HC 1152C	Bottom Rear	1	180°	48 in. (121.9 cm)
0381-1716	HC 1161C	Bottom Rear	1	75°	60 in. (152.4 cm)
0381-1717	HC 1162C	Bottom Rear	1	180°	60 in. (152.4 cm)
0381-1718	HC 1170C	Bottom Rear	1	90°	72 in. (182.9 cm)
0381-1719	HC 1171C	Bottom Rear	1	75°	72 in. (182.9 cm)
0381-1720	HC 1172C	Bottom Rear	1	180°	72 in. (182.9 cm)
<b>Victor Bulldog with Seat Designed for Harris® Style Tip</b>					
0381-1698	HC 1100C H1	Bottom Rear	1	90°	21" (53.3 cm)
0381-1721	HC 1131C H1	Bottom Rear	1	75°	36" (91.4 cm)
0381-1722	HC 1151C H1	Bottom Rear	1	75°	48" (121.9 cm)
0381-1745	HC 1171C H1	Bottom Rear	1	75°	72" (182.9 cm)

Harris® is a registered trademark of the Lincoln Electric Company.

**WARNING:** Use add-on flashback arrestors.  
Not for use with acetylene.

For best performance, use the following recommended equipment:

### Flashback Arrestors

Gas Service	Part No.	Model	Type	Recommended Tip Size
Oxygen	0657-0010	*FB-O	Torch Mount	Up to size: 8
	0657-0014	FB-OR	Regulator Mount	Up to size: 8
	0657-0076	*FBHC-O	Torch Mount/High Flow	Size: 10 and larger
	0657-0078	FBHC-OR	Regulator Mount/High Flow	Size: 10 and larger
Fuel	0657-0011	*FB-F	Torch Mount	–
	0657-0015	FB-FR	Regulator Mount	–

\*Torch mount models also protect the hose

### Hoses

(Contact local distributor for hose information)

- Oxygen:
  - 3/8" (9.53 mm) I.D. with "B" hose (9/16"-18 LH) connections.
  - Use T-grade hose
- Fuel:
  - 3/8" (9.53 mm) I.D. with "B" hose (9/16"-18 LH) connections.
  - Use T-grade hose

### Regulators

- Oxygen:
  - ELC4, ESS4-125-540R, ESS7-125-540, SR 450D-540, SR 700D-540 cylinder, SR 700E-540 cylinder or L 700D/E-500/750 line supply, LC 350DR 540 liquid cylinder
- Fuel:
  - ESS4-125-510LP, SR 461D-510 cylinder, SR 711B/C/D-510, L 711B/C/D-500/750 line supply

## ST 2600FC Series

Heavy-duty straight cutting torch



For use with all fuel gases with appropriate tip.

- Cutting capacity 1/8" (3.2 mm) to 8" (203.2 mm)
- Includes built-in patented flashback arrestors and reverse flow check valves for added safety

### Ordering Information

Part No.	Model No.	Lever Position	Tip Series	Head Angle	Length
0381-1486	SST 2600FC	Top Rear	1	90°	17 in. (43.2 cm)
0381-1487	SST 2601FC	Top Rear	1	75°	17 in. (43.2 cm)
0381-1480	ST 2600FC	Top Rear	1	90°	21 in. (53.3 cm)
0381-1482	ST 2601FC	Top Rear	1	75°	21 in. (53.3 cm)
0381-1483	ST 2601FCL*	Top Rear	1	75°	21 in. (53.3 cm)
0381-1484	ST 2602FC	Top Rear	1	180°	21 in. (53.3 cm)
0381-1490	ST 2610FC	Top Rear	1	90°	27 in. (68.6 cm)
0381-1491	ST 2611FC	Top Rear	1	75°	27 in. (68.6 cm)
0381-1492	ST 2612FC	Top Rear	1	180°	27 in. (68.6 cm)
0381-1496	ST 2630FC	Top Rear	1	90°	36 in. (91.4 cm)
0381-1498	ST 2631FC	Top Rear	1	75°	36 in. (91.4 cm)
0381-1500	ST 2632FC	Top Rear	1	180°	36 in. (91.4 cm)
0381-1502	ST 2650FC	Top Rear	1	90°	48 in. (121.9 cm)
0381-1503	ST 2651FC	Top Rear	1	75°	48 in. (121.9 cm)
0381-1514	ST 2651FCL*	Top Rear	1	75°	48 in. (121.9 cm)
0381-1504	ST 2652FC	Top Rear	1	180°	48 in. (121.9 cm)
0381-1515	ST 2652FCL*	Top Rear	1	180°	48 in. (121.9 cm)
0381-1506	ST 2670FC	Top Rear	1	90°	72 in. (182.9 cm)
0381-1508	ST 2671FC	Top Rear	1	75°	72 in. (182.9 cm)
0381-1510	ST 2672FC	Top Rear	1	180°	72 in. (182.9 cm)

\*Locking lever

## ST 1000FC Series

Heavy-duty straight cutting torch



For use with all fuel gases with appropriate tip.

- Cutting capacity 1/8" (3.2 mm) to 5" (127.0 mm)
- Includes built-in patented flashback arrestors and reverse flow check valves for added safety
- Built-in flashback arrestors no need for accessory flash arrestors
- Built-in reverse flow check valves no need for accessory check valves

### Ordering Information

Part No.	Model No.	Lever Position	Tip Series	Head Angle	Length
0381-1640	SST 1000FC	Bottom Rear	1	90°	17" (43.2 cm)
0381-1642	SST 1001FC	Bottom Rear	1	75°	17" (43.2 cm)
0381-1641	ST 1000FC	Bottom Rear	1	90°	21" (53.3 cm)
0381-1643	ST 1001FC	Bottom Rear	1	75°	21" (53.3 cm)
0381-1644	ST 1030FC	Bottom Rear	1	90°	36" (91.4 cm)
0381-1645	ST 1031FC	Bottom Rear	1	75°	36" (91.4 cm)
0381-1646	ST 1032FC	Bottom Rear	1	180°	36" (91.4 cm)
0381-1647	ST 1050FC	Bottom Rear	1	90°	48" (121.9 cm)
0381-1648	ST 1051FC	Bottom Rear	1	75°	48" (121.9 cm)
0381-1649	ST 1052FC	Bottom Rear	1	180°	48" (121.9 cm)

## ST 900FC Series

Heavy duty straight cutting torch



For use with all fuel gases with appropriate tip.

- Cutting capacity: 1/8 in. (3.2 mm) to 5 in. (127.0 mm)
- Hose connections are 9/16 in. -18 unless noted
- Includes built-in patented flashback arrestors and reverse flow check valves for added safety
- Built-in flashback arrestors no need for accessory flash arrestors
- Built-in reverse flow check valves no need for accessory check valves

### Ordering Information

Part No.	Model No.	Lever Position	Tip Series	Head Angle	Length
0381-1620	SST 900FC	Top Rear	1	90°	17 in. (43.2 cm)
0381-1622	SST 901FC	Top Rear	1	75°	17 in. (43.2 cm)
0381-1621	ST 900FC	Top Rear	1	90°	21 in. (53.3 cm)
0381-1623	ST 901FC	Top Rear	1	75°	21 in. (53.3 cm)
0381-1628	ST 912FC	Top Rear	1	180°	27 in. (68.6 cm)
0381-1624	ST 930FC	Top Rear	1	90°	36 in. (91.4 cm)
0381-1625	ST 931FC	Top Rear	1	75°	36 in. (91.4 cm)
0381-1626	ST 932FC	Top Rear	1	180°	36 in. (91.4 cm)
0381-1629	ST 950FC	Top Rear	1	90°	48 in. (121.9 cm)
0381-1630	ST 951FC	Top Rear	1	75°	48 in. (121.9 cm)
0381-1631	ST 952FC	Top Rear	1	180°	48 in. (121.9 cm)
0381-1654	ST 972FC	Top Rear	1	180°	72 in. (182.9 cm)
0381-1685	ST 991FC	Top Rear	1	75°	96 in. (243.8 cm)

## ST 400C Series

Heavy-duty



For use with all fuel gases 5 psig and above.

- Cutting capacity up to 6 in. (300.0 mm)
- Hose connections are 9/16in.-18 unless noted
- Built-in reverse flow check valves no need for accessory check valves

### Special designed alloy Material:

- 3x the tensile strength of Brass
- Ergonomic, textured, precision contoured handle is designed to reduce operator fatigue and provide better grip
- Durable to withstand tough use and prevention of dents and scratches

### Intuitive knobs:

- Color-coded
- Clearly marked lettering with increase/decrease label
- Understandable in any language

### Ordering Information

Part No.	Model No.	Lever Position	Tip Series	Head Angle	Length
0381-1987	ST 400C	Top Rear	1	90°	21 in. (53.3 cm)

## Victor Machine Torches

Available in two and three hose versions. Two hose torches are available in 4.5 in. (114.3 mm), 10 in. (254.0 mm) and 18 in. (457.2 mm) models, and three hose torches are available in 10 in. (254.0 mm) and 18 in. (457.2 mm) models.

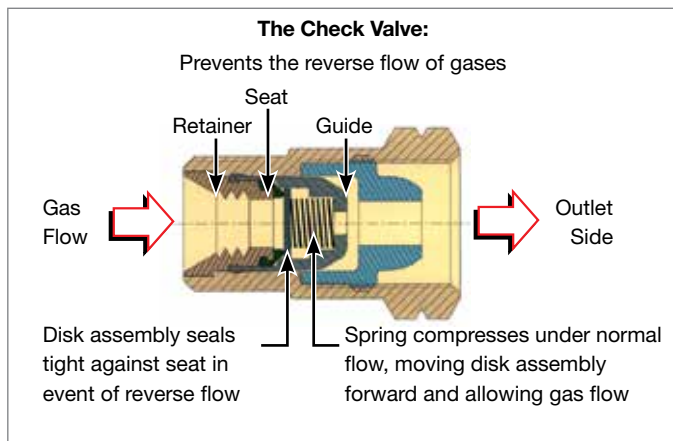

## Straight Cutting Torches & Cutting Machine Reference Guide

Torch Model	Tip Series	Fuel Gas Usage	Cut Capacity
<b>"FC" Models</b>			
ST 2600FC VanGuard	1	Any Fuel Gas	1/8 in. to 8 in. (3.2 to 203.2 mm)
ST 1000FC VanGuard	1	Any Fuel Gas	1/8 in. to 5 in. (3.2 to 127.0 mm)
ST 900FC VanGuard	1	Any Fuel Gas	1/8 in. to 5 in. (3.2 to 127.0 mm)
<b>Machine Torches</b>			
MT 200 (2 Hose)	1	Any Fuel Gas	7 in. (177.8 mm)
MT 300 (3 Hose)	1	Any Fuel Gas	12" (304.8 mm)
MT 1065 (3 Hose)	1	Any Fuel Gas	7 in. (177.8 mm)
MT 5 (3 Hose)	1	Any Fuel Gas	7 in. (177.8 mm)

### Tip Type

**BTN** for use with Natural Gas & Propane.

**BTMP** for use with Propylene Gases

(For use with MT200, MT300 Series Machine Cutting Torches)

Length of Bevel	Tip Size	Speed IPM	Oxygen Pressure	Fuel Pressure	Cutting Oxygen Pressure
<b>MT 200 Series</b>					
1	4	10/18	60/75	8/10	—
1.5	4	8/16	60/75	8/10	—
2	4	6/14	60/75	8/10	—
2.5	4	5/12	60/75	8/10	—
3	5	6/11	60/75	8/12	—
3.5	5	5/10	60/75	8/12	—
4	5	4/9	60/75	8/12	—
4.5	5	4/8	60/75	8/12	—
5	6	3/8	65/85	8/15	—
5.5	6	3/7	65/85	8/15	—
6	6	3/6	65/85	8/15	—
<b>MT 300N Series</b>					
1	4	10/18	35/65	10/12	40/60
1.5	4	8/16	35/65	10/12	40/60
2	4	6/14	35/65	10/12	40/60
2.5	4	5/12	35/65	10/12	40/60
3	5	6/11	35/65	10/12	40/65
3.5	5	5/10	35/65	10/12	40/65
4	5	4/9	35/65	10/12	40/65
4.5	5	4/8	35/65	10/12	40/65
5	6	3/8	35/65	10/12	40/75
5.5	6	3/7	35/65	10/12	40/75
6	6	3/6	35/65	10/12	40/75

Bevels of 30° to 70° are possible on mild steel and most alloy steel without a preheat attachment. High gas withdrawal rates will require manifolding. Consult your gas supplier.

Check Valve  
Pair Pack



Accessory  
Reverse Flow  
Check Valves  
Supplied with  
all machine  
torches  
or added  
operator  
safety

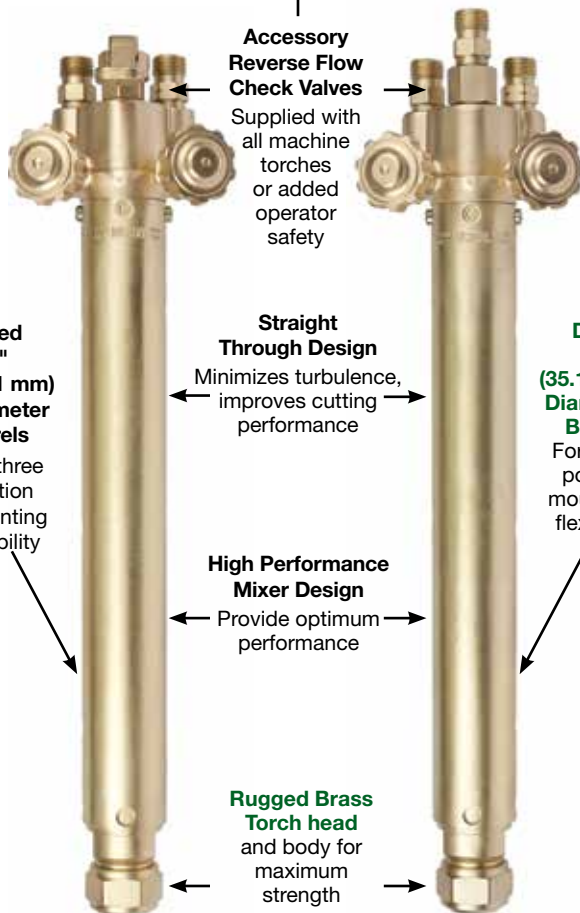

**Pre-Drilled 1.38" (35.1 mm) Diameter Barrels**  
For three position mounting flexibility

**Straight Through Design**  
Minimizes turbulence, improves cutting performance

**Pre-Drilled 1.38" (35.1 mm) Diameter Barrels**  
For three position mounting flexibility

**High Performance Mixer Design**  
Provide optimum performance

**Rugged Brass Torch head and body** for maximum strength

**MT 200 Series**  
Two hose model

**MT 300 Series**  
Three hose model

Victor machine cutting torches are available in two and three hose models. Three hose torches are high performance “straight through” design that minimizes turbulence and improves cut quality. Accessory reverse flow check valves are supplied for use at the torches inlet connection. All machine torches use Series 1 cutting tips and are supplied with accessory reverse flow check valves to be used on the torch inlet connections.

## MT 300 Series

Three Hose



- Cut capacity: 12 in. (304.8 mm)
- Series 1 cutting tips

Ordering Information					
Part No.	Model No.	Total Length	Barrel Length	Racking Length	Gas
0380-0222	MT 310A	14 in. (355.6 mm)	10 in. (254.0 mm)	7 in. (177.8 mm)	Acetylene*
0380-0220	MT 310N	14 in. (355.6 mm)	10 in. (254.0 mm)	7 in. (177.8 mm)	LP/Natural Gas**
0380-0221	MT 310NV	14 in. (355.6 mm)	10 in. (254.0 mm)	7 in. (177.8 mm)	LP/Natural Gas**
0380-0223	MT 310AV	14 in. (355.6 mm)	10 in. (254.0 mm)	7 in. (177.8 mm)	Acetylene*
0380-0227	MT 318A	22.5 in. (571.5 mm)	18 in. (457.2 mm)	15 in. (381.0 mm)	Acetylene*
0380-0228	MT 318AV	22.5 in. (571.5 mm)	18 in. (457.2 mm)	15 in. (381.0 mm)	Acetylene*
0380-0225	MT 318N	22.5 in. (571.5 mm)	18 in. (457.2 mm)	15 in. (381.0 mm)	LP/Natural Gas**
0380-0226	MT 318NV	22.5 in. (571.5 mm)	18 in. (457.2 mm)	15 in. (381.0 mm)	LP/Natural Gas**

*\*May also be used on other pressurized fuel gases.  
\*\*May also be used on other fuel gases except acetylene.  
\*\*\*Supplied with rack soldered to barrel.  
Other machine torch models available. Ask for details.  
Gear racks: Must be ordered separately.*

## MT 5

Three Hose



- Cutting capacity - 7" (177.8 mm)
- For use with any fuel gas 2 PSI and above
- Series 1 cutting tips
- Supplied with rack soldered to barrel

Ordering Information						
Part No.	Model No.	Total Length	Barrel Diameter	Barrel Length	Racking Length	Gas
0380-0208	MT 5	8.5 in. (215.9 mm)	1.38 in. (35.1 mm)	5.38 in. (136.7 mm)	5.38 in. (136.7 mm)	All

## MT 200 Series

Two Hose



- Cut capacity: 7 in. (177.8 mm)
- Series 1 cutting tips

Ordering Information					
Part No.	Model No.	Total Length	Barrel Length	Racking Length	Gas
0380-0215	MT 204A	8.5 in. (215.9 mm)	4.5 in. (114.3 mm)	–	Acetylene*
0397-0217	MT 204A***	8.5 in. (215.9 mm)	4.5 in. (114.3 mm)	–	Acetylene*
0380-0217	MT 210A	14 in. (355.6 mm)	10 in. (254.0 mm)	7 in. (177.8 mm)	Acetylene*
0380-0216	MT 210N	14 in. (355.6 mm)	10 in. (254.0 mm)	7 in. (177.8 mm)	LP/Natural Gas**

*\*May also be used on other pressurized fuel gases.  
\*\*May also be used on other fuel gases except acetylene.  
\*\*\*Supplied with rack soldered to barrel.  
Other machine torch models available. Ask for details.  
Gear racks: Must be ordered separately.*

## MT 1065

Three Hose



- Cut capacity: 7 in. (177.8 mm)
- For use with all fuel gases
- Series 1 cutting tips
- Multi-torch beveling

Ordering Information					
Part No.	Model No.	Total Length	Barrel Diameter	Barrel Length	Gas
0399-1065	MT 1065N	8 in. (203.2 mm)	1.25 in. (31.8 mm)	4 in. (101.6 mm)	All
0399-1121	MT 1065A	8 in. (203.2 mm)	1.25 in. (31.8 mm)	4 in. (101.6 mm)	Acetylene

## Gear Racks

- For use with MT 200 and MT 300 Series cutting torches
- Must be ordered separately



Ordering Information				
Part No.	Length	Pitch	Cutting Machine	Actual Length
0319-0054	10 in. (254.0 mm) Rack Kit	32	MT 210 & MT 310	7.8 in. (198.1 mm)
0319-0055	18 in. (457.2 mm) Rack Kit	32	MT 318	14.5 in. (368.3 mm)

Section & Reference Information

**Cutting Orifice Reference Chart - Cutting Tip Size**

For all standard cutting tips except Series MTH high speed models

000	00	0	1	2	3	4	5	6	7	8	10	12
0.027	0.033	0.041	0.047	0.060	0.071	0.083	0.100	0.121	0.141	0.162	0.185	0.221

**Orifice Diameter** - inches (Orifice diameters shown actual size)

**Code for Fuel Gases**

<b>A</b>	<b>Acetylene</b>
<b>LP</b>	<b>Propane/Natural Gas</b>
<b>P</b>	<b>Propylene</b>

**Material Thickness – Tip Size**

Material Thickness		Tip Size
Inches	mm	
1/8 in.	3.2 mm	000
1/4 in.	6.4 mm	00
3/8 – 1/2 in.	9.5 - 12.7 mm	0
3/4 in.	19.1 mm	1
1 – 1 1/2 in.	25.4 - 38.1 mm	2
2 – 2 1/2 in.	50.8 - 63.5 mm	3
3 in.	76.2 mm	4
4 – 5 in.	102 - 127 mm	5
6 – 8 in.	152 - 203 mm	6*
10 in.	254 mm	7*
12 in.	305 mm	8*

\*For best results, use "High Flow Handles" and 3/8" hose

**Preheat Chart for Propylene & LP Tips**

Torch Series	Preheat Oxygen (psig)	Preheat Fuel (psig)
MT 200	--	8 oz and up
MT 300	30/35	8 oz and up
ST 2600FC	--	1 psig and up
ST 900FC	--	5 psig and up
ST 1000FC	--	5 psig and up

**Cutting Torches**

Handle	Cutting Attachment	Fuel Gas
<b>Cutting Torches</b>		
315FC, H 315FC	CA 2460-90°	All
315FC, H 315FC	CA 2461-75°	All
315FC, H 315FC	CA 2462-180°	All
<b>Straight Torches</b>		
ST 2600FC	–	All
ST 1000FC	–	All
ST 900FC	–	All
*HC 1200C	–	All
<b>Machine Torches</b>		
MT 200	–	A, LP
MT 300	–	A, LP

**Gouging Depth Tip Chart**

Approximate Gouge Depth				
Depth of gouge will vary due to angle of tip and cutting pressure.				
Type	Tip Size	Depth of Gouge	O <sub>2</sub> psi	C <sub>2</sub> H <sub>2</sub> psi
118	0	1/8 in. - 1/4 in.	30-45	5-7
	2	1/4 in. - 3/8 in.	30-45	5-7
	8	1/4 in. - 1/2 in.	30-55	6-8
218	4	1/4 in. - 3/4 in.	30-65	8-10
	6	3/8 in. - 1 in.	30-65	10-12

CUTTING TIPS

**Tip Nut**

**0309-0018**

For Series 1 cutting tips









**0309-0003**

For Series 3 cutting tips

## Series 1 – Acetylene Cutting Tips

### Acetylene

Series 1 tip style, fuel gas usage and Victor equipment compatibility shown below

Type		Fuel Gas	Application
101		A	<ul style="list-style-type: none"> <li>General purpose</li> <li>Hand and machine torch cutting</li> </ul>
101 30°		A	<ul style="list-style-type: none"> <li>General purpose</li> <li>Hand and machine torch cutting 30°, with torch perpendicular</li> </ul>
101-L		A	<ul style="list-style-type: none"> <li>General purpose, extra length tips</li> </ul>
108		A	<ul style="list-style-type: none"> <li>Boiler tube removal</li> <li>Tips are short to insert head and tip inside tube</li> </ul>
112		A	<ul style="list-style-type: none"> <li>Cutting close to bulk heads</li> <li>Hand cutting of rivet heads</li> </ul>
118 Tip (Round)		A	<ul style="list-style-type: none"> <li>Deseaming, scarfing, gouging, weld preparation, removing defective welds, washing rivets</li> </ul>
118 Tip (Sides Cutaway)		A	<ul style="list-style-type: none"> <li>Deseaming, scarfing, gouging, weld preparation, removing defective welds, washing rivets</li> </ul>

Tip packaging is color coded with reference to fuel gas usage. Other special application tips available. Contact Technical Services at 1-800-426-1888



CUTTING TIPS

Data compiled using mild steel as test material.

\*Applicable for three hose machine torch only. With a two hose cutting torch, preheat pressure is set by the cutting oxygen.

\*\*For best results use ST2600FC series torches and 3/8 in. hose when using tip size 6 or larger.

\*\*\*All pressures are measured at the regulator using 25 ft. x 1/4 in. hose through tip size 5 and 25 ft. x 3/8 in.

\*\*\*\*Oxygen consumption is 1.1 times the acetylene under neutral flame conditions.

**WARNING:** At no time should the withdrawal rate of an individual acetylene cylinder exceed 1/7 of the cylinder contents per hour. If additional flow capacity is required use an acetylene manifold system of sufficient size to supply the necessary volume.

## Victor Series 1 Type 101 30°



- General purpose
- Hand and machine torch cutting 30°, with torch perpendicular

Metal Thickness	Size	Part No.	Cutting Oxygen*** (psig)	Cutting Oxygen (SCFH)	Preheat Oxygen *(psig)	Preheat Oxygen (SCFH)	Acetylene (psig)	Acetylene ****(SCFH)	Speed ipm	Kerf Width
3/8 in. (0.9 mm)	0	0330-0198	25 / 30	55 / 60	3 / 5	5 / 9	3 / 5	5 / 8	24 / 28	.06
1/2 in. (1.2 mm)	0	0330-0198	30 / 35	60 / 65	3 / 6	7 / 11	3 / 5	6 / 10	20 / 24	.06
3/4 in. (1.9 mm)	1	0330-0199	30 / 35	80 / 85	4 / 7	9 / 14	3 / 5	8 / 13	17 / 21	.07
1 in. (2.5 mm)	2	0330-0284	35 / 40	140 / 150	4 / 9	11 / 18	3 / 6	10 / 16	15 / 19	.09

## Victor Series 1 Type 101-L

- General purpose
- Extra length tips



Metal Thickness	Size	Part No.	Cutting Oxygen *** (psig)	Cutting Oxygen (SCFH)	Preheat Oxygen * (psig)	Preheat Oxygen (SCFH)	Acetylene (psig)	Acetylene ****(SCFH)	Speed ipm	Kerf Width
3 in. (7.6 mm)	4	0330-0531	40 / 50	270 / 320	6 / 17	20 / 33	5 / 10	18 / 30	9 / 12	.12
6 in. (15.2 mm)	6**	0330-0535	45 / 40	500 / 600	10 / 22	33 / 48	7 / 13	30 / 44	6 / 8	.18

## Victor Series 1 Type 108



- Boiler tube removal
- Tip is short to insert head and tip inside tube

Metal Thickness	Size	Part No.	Cutting Oxygen *** (psig)	Cutting Oxygen (SCFH)	Preheat Oxygen * (psig)	Preheat Oxygen (SCFH)	Acetylene (psig)	Acetylene ****(SCFH)	Speed ipm	Kerf Width
3/8 in. (0.9 mm)	0	0330-0058	25 / 30	55 / 60	3 / 5	5 / 9	3 / 5	5 / 8	24 / 28	.06
1/2 in. (1.2 mm)	0	0330-0058	30 / 35	60 / 65	3 / 6	7 / 11	3 / 5	6 / 10	20 / 24	.06
3/4 in. (1.9 mm)	1	0330-0059	30 / 35	80 / 85	4 / 7	9 / 14	3 / 5	8 / 13	17 / 21	.07
1 in. (2.5 mm)	2	0330-0063	35 / 40	140 / 150	4 / 9	11 / 18	3 / 6	10 / 16	15 / 19	.09
1 1/2 in. (3.8 mm)	2	0330-0063	40 / 45	150 / 160	4 / 12	13 / 20	3 / 7	12 / 18	13 / 17	.09
2 in. (5 mm)	3	0330-0064	40 / 45	210 / 225	5 / 14	15 / 24	4 / 9	14 / 22	12 / 15	.11
2 1/2 in. (6.4 mm)	3	0330-0064	45 / 50	225 / 240	5 / 16	18 / 29	4 / 10	16 / 26	10 / 13	.11
3 in. (7.6 mm)	4	0330-0065	40 / 50	270 / 320	6 / 17	20 / 33	5 / 10	18 / 30	9 / 12	.12

## G-Series Series 1 Type 108

Metal Thickness	Size	Part no.	Model no.	Cutting Oxygen *** (psig)	Cutting Oxygen (SCFH)	Preheat Oxygen * (psig)	Preheat Oxygen (SCFH)	Acetylene (psig)	Acetylene ****(SCFH)	Speed ipm	Kerf Width
3/8 in. (0.9 mm)	0	6700C2990	CS11080	25 / 30	55 / 60	3 / 5	5 / 9	3 / 5	5 / 8	24 / 28	.06
1/2 in. (1.2 mm)	0	6700C2990	CS11080	30 / 35	60 / 65	3 / 6	7 / 11	3 / 5	6 / 10	20 / 24	.06
3/4 in. (1.9 mm)	1	6700C2991	CS11081	30 / 35	80 / 85	4 / 7	9 / 14	3 / 5	8 / 13	17 / 21	.07
1 in. (2.5 mm)	2	6700C2992	CS11082	35 / 40	140 / 150	4 / 9	11 / 18	3 / 6	10 / 16	15 / 19	.09
1 1/2 in. (3.8 mm)	2	6700C2992	CS11082	40 / 45	150 / 160	4 / 12	13 / 20	3 / 7	12 / 18	13 / 17	.09
2 in. (5 mm)	3	6700C2993	CS11083	40 / 45	210 / 225	5 / 14	15 / 24	4 / 9	14 / 22	12 / 15	.11
2 1/2 in. (6.4 mm)	3	6700C2993	CS11083	45 / 50	225 / 240	5 / 16	18 / 29	4 / 10	16 / 26	10 / 13	.11
3 in. (7.6 mm)	4	6700C2994	CS11084	40 / 50	270 / 320	6 / 17	20 / 33	5 / 10	18 / 30	9 / 12	.12

CUTTING TIPS

Data compiled using mild steel as test material.

\*Applicable for three hose machine torch only. With a two hose cutting torch, preheat pressure is set by the cutting oxygen.

\*\*For best results use ST2600FC series torches and 3/8 in. hose when using tip size 6 or larger.

\*\*\*All pressures are measured at the regulator using 25 ft. x 1/4 in. hose through tip size 5 and 25 ft. x 3/8 in. hose for tip size 6 and larger.

\*\*\*\*Oxygen consumption is 1.1 times the acetylene under neutral flame conditions.

**WARNING:** At no time should the withdrawal rate of an individual acetylene cylinder exceed 1/7 of the cylinder contents per hour. If additional flow capacity is required use an acetylene manifold system of sufficient size to supply the necessary volume.



## Victor Series 1 Type 112



- Cutting close to bulk heads
- Hand cutting of rivet heads

Metal Thickness	Size	Part No.	Cutting Oxygen (psig) ***	Cutting Oxygen (SCFH)	Preheat Oxygen (psig) *	Preheat Oxygen (SCFH)	Acetylene (psig)	Acetylene ****(SCFH)	Speed ipm	Kerf Width
1 in. (2.5 mm)	2	0330-0086	35 / 40	140 / 150	4 / 9	11 / 18	3 / 6	10 / 16	15 / 19	.09
1 1/2 in. (3.8 mm)	2	0330-0086	40 / 45	150 / 160	4 / 12	13 / 20	3 / 7	12 / 18	13 / 17	.09

## Victor Series 1 Type 118 Round



- Deseaming, scarfing, gouging
- Rivet washing
- Weld preparation

Metal Thickness	Size	Part No.	Cutting Oxygen (psig) ***	Cutting Oxygen (SCFH)	Preheat Oxygen (psig) *	Preheat Oxygen (SCFH)	Acetylene (psig)	Acetylene ****(SCFH)	Speed ipm	Kerf Width
3/8 in. (0.9 mm)	0	0330-0109	25 / 30	55 / 60	3 / 5	5 / 9	3 / 5	5 / 8	24 / 28	.06
1/2 in. (1.2 mm)	0	0330-0109	30 / 35	60 / 65	3 / 6	7 / 11	3 / 5	6 / 10	20 / 24	.06
1 in. (2.5 mm)	2	0330-0113	35 / 40	140 / 150	4 / 9	11 / 18	3 / 6	10 / 16	15 / 19	.09
1 1/2 in. (3.8 mm)	2	0330-0113	40 / 45	150 / 160	4 / 12	13 / 20	3 / 7	12 / 18	13 / 17	.09
3 in. (7.6 mm)	4	0330-0114	40 / 50	270 / 320	6 / 17	20 / 33	5 / 10	18 / 30	9 / 12	.12

## G-Series Series 1 Type 118 (Round)

Metal Thickness	Size	Part no.	Model no.	Cutting Oxygen (psig) ***	Cutting Oxygen (SCFH)	Preheat Oxygen (psig) *	Preheat Oxygen (SCFH)	Acetylene (psig)	Acetylene ****(SCFH)	Speed ipm	Kerf Width
3/8 in. (0.9 mm)	0	6700C2700	CS11180	25 / 30	55 / 60	3 / 5	5 / 9	3 / 5	5 / 8	24 / 28	.06
1/2 in. (1.2 mm)	0	6700C2700	CS11180	30 / 35	60 / 65	3 / 6	7 / 11	3 / 5	6 / 10	20 / 24	.06
1 in. (2.5 mm)	2	6700C2701	CS11182	35 / 40	140 / 150	4 / 9	11 / 18	3 / 6	10 / 16	15 / 19	.09
1 1/2 in. (3.8 mm)	2	6700C2701	CS11182	40 / 45	150 / 160	4 / 12	13 / 20	3 / 7	12 / 18	13 / 17	.09
3 in. (7.6 mm)	4	6700C2702	CS11184	40 / 50	270 / 320	6 / 17	20 / 33	5 / 10	18 / 30	9 / 12	.12

## Victor Series 1 Type 118 (Sides Cutaway)



- Deseaming, scarfing, gouging
- Rivet washing
- Weld preparation

Metal Thickness	Size	Part No.	Cutting Oxygen (psig) ***	Cutting Oxygen (SCFH)	Preheat Oxygen (psig) *	Preheat Oxygen (SCFH)	Acetylene (psig)	Acetylene ****(SCFH)	Speed ipm	Kerf Width
6 in. (15.2 mm)	6**	0330-0115	45 / 40	500 / 600	10 / 22	33 / 48	7 / 13	30 / 44	6 / 8	.18
8 in. (20.3 mm)	6**	0330-0115	45 / 55	500 / 600	10 / 25	37 / 55	7 / 14	34 / 50	5 / 6	.19
12 in. (30.5 mm)	8**	0330-0116	45 / 55	900 / 1000	20 / 35	53 / 68	10 / 15	48 / 62	3 / 5	.41

## G-Series Series 1 Type 118 (Sides Cutaway)

Metal Thickness	Size	Part no.	Model no.	Cutting Oxygen (psig) ***	Cutting Oxygen (SCFH)	Preheat Oxygen (psig) *	Preheat Oxygen (SCFH)	Acetylene (psig)	Acetylene ****(SCFH)	Speed ipm	Kerf Width
6 in. (15.2 mm)	6**	6700C2703	CS11186	45 / 40	500 / 600	10 / 22	33 / 48	7 / 13	30 / 44	6 / 8	.18
8 in. (20.3 mm)	6**	6700C2703	CS11186	45 / 55	500 / 600	10 / 25	37 / 55	7 / 14	34 / 50	5 / 6	.19
12 in. (30.5 mm)	8**	6700C2704	CS11188	45 / 55	900 / 1000	20 / 35	53 / 68	10 / 15	48 / 62	3 / 5	.41

Data compiled using mild steel as test material.

\*Applicable for three hose machine torch only. With a two hose cutting torch, preheat pressure is set by the cutting oxygen.

\*\*For best results use ST2600FC series torches and 3/8" hose when using tip size 6 or larger.

\*\*\*All pressures are measured at the regulator using 25' x 1/4" hose through tip size 5 and 25' x 3/8" hose for tip size 6 and larger.















\*\*\*\*Oxygen consumption is 1.1 times the acetylene under neutral flame conditions.

**WARNING:** At no time should the withdrawal rate of an individual acetylene cylinder exceed 1/7 of the cylinder contents per hour. If additional flow capacity is required use an acetylene manifold system of sufficient size to supply the necessary volume.

Series 1 – Propylene Cutting Tips

Propylene

Series 1 tip style, fuel gas usage and Victor equipment compatibility shown below

Type		Fuel Gas	Application
GPP	 	P	<ul style="list-style-type: none"> <li>General purpose</li> <li>Hand and machine torch cutting</li> </ul>
HPP	 	P	<ul style="list-style-type: none"> <li>Heavy preheat for scrap, bevel and other heavy preheat requirements</li> </ul>
MTHP	 	P	<ul style="list-style-type: none"> <li>High speed machine cutting through 10" (252 mm)</li> </ul>
303MP	 	P	<ul style="list-style-type: none"> <li>General purpose</li> <li>Hand and machine torch cutting</li> </ul>
BTMP	 	P	<ul style="list-style-type: none"> <li>High performance</li> <li>Bevel cutting</li> </ul>
GTB	 	P	<ul style="list-style-type: none"> <li>Gouging tip (bent)</li> <li>Removing welds</li> </ul>
318MP	 	P	<ul style="list-style-type: none"> <li>General purpose</li> <li>Gouging and rivet washing</li> </ul>

Tip packaging is color coded with reference to fuel gas usage. Other special application tips available. Contact Technical Services at 1-800-426-1888



## Victor Series 1 Type GPP



- General purpose
- Hand and machine torch cutting

Metal Thickness	Size	Part No.	Cutting Oxygen *** (psig)	Cutting Oxygen (SCFH)	Preheat Oxygen *(psig)	Preheat Oxygen (SCFH)	Fuel (psig)	Fuel **** (SCFH)	Speed ipm	Kerf Width
1/8 in. (3.2 mm)	000	0333-0260	20/25	12/14	REFERENCE PREHEAT CHART ON PAGE 56	23/108	3/5	5/6	24/28	0.04
1/4 in. (6.4 mm)	00	0333-0261	20/25	22/26		23/108	3/5	5/7	21/25	0.04
3/8 in. (9.5 mm)	0	0333-0262	25/30	45/55		23/108	3/5	8/10	20/24	0.06
3/8 in. (9.5 mm)	0	0387-0154#	25/30	45/55		23/108	3/5	8/10	20/24	0.06
1/2 in. (12.7 mm)	0	0333-0262	30/35	50/55		23/108	3/5	8/10	18/22	0.06
1/2 in. (12.7 mm)	0	0387-0154#	30/35	50/55		23/108	3/5	8/10	18/22	0.06
3/4 in. (19.1 mm)	1	0333-0263	30/35	70/80		23/108	4/6	10/12	15/20	0.08
3/4 in. (19.1 mm)	1	0387-0155#	30/35	70/80		23/108	4/6	10/12	15/20	0.08
1 in. (25.4 mm)	2	0333-0264	35/40	115/125		23/108	4/8	12/15	14/18	0.09
1 in. (25.4 mm)	2	0387-0156#	35/40	115/125		23/108	4/8	12/15	14/18	0.09
1 1/2 in. (38.1 mm)	2	0333-0264	40/45	125/135		23/108	5/9	12/15	12/16	0.09
2 in. (50.8 mm)	3	0333-0265	40/50	150/175		23/108	5/9	14/18	10/14	0.10
2 1/2 in. (63.5 mm)	3	0333-0265	45/50	175/200		23/108	6/10	14/18	9/12	0.10
3 in. (76.2 mm)	4	0333-0266	45/50	210/250		23/108	8/12	16/20	8/11	0.12
4 in. (102 mm)	5	0333-0267	45/55	300/360		23/108	8/12	20/30	7/10	0.14
5 in. (127 mm)	5	0333-0267	50/55	330/360		23/108	8/12	20/30	6/9	0.14
6 in. (152 mm)	6**	0333-0268	45/55	400/500		23/153	10/15	25/35	5/7	0.17
8 in. (203 mm)	6**	0333-0268	55/65	450/500		23/153	10/15	25/35	4/6	0.18
10 in. (254 mm)	7	0333-0269	55/65	450/500		23/153	8/12	25/35	3/5	0.34
12 in. (305 mm)	8	0333-0270	60/70	450/500		23/153	10/14	25/35	3/4	0.14

## G-Series Series 1 Type GPP

Metal Thickness	Size	Part no.	Model no.	Cutting Oxygen *** (psig)	Cutting Oxygen (SCFH)	Preheat Oxygen *(psig)	Preheat Oxygen (SCFH)	Fuel (psig)	Fuel **** (SCFH)	Speed ipm	Kerf Width
1/8 in. (3.2 mm)	000	6700C2588	CSGPP000	20/25	12/14	REFERENCE PREHEAT CHART ON PAGE 56	23/108	3/5	5/6	24/28	0.04
1/4 in. (6.4 mm)	00	6700C2589	CSGPP00	20/25	22/26		23/108	3/5	5/7	21/25	0.04
3/8 in. (9.5 mm)	0	6700C2590	CSGPP0	25/30	45/55		23/108	3/5	8/10	20/24	0.06
1/2 in. (12.7 mm)	0	6700C2590	CSGPP0	30/35	50/55		23/108	3/5	8/10	18/22	0.06
3/4 in. (19.1 mm)	1	6700C2591	CSGPP1	30/35	70/80		23/108	4/6	10/12	15/20	0.08
1 in. (25.4 mm)	2	6700C2592	CSGPP2	35/40	115/125		23/108	4/8	12/15	14/18	0.09
1 1/2 in. (38.1 mm)	2	6700C2592	CSGPP2	40/45	125/135		23/108	5/9	12/15	12/16	0.09
2 in. (50.8 mm)	3	6700C2593	CSGPP3	40/50	150/175		23/108	5/9	14/18	10/14	0.10
2 1/2 in. (63.5 mm)	3	6700C2593	CSGPP3	45/50	175/200		23/108	6/10	14/18	9/12	0.10
3 in. (76.2 mm)	4	6700C2594	CSGPP4	45/50	210/250		23/108	8/12	16/20	8/11	0.12
4 in. (102 mm)	5	6700C2595	CSGPP5	45/55	300/360		23/108	8/12	20/30	7/10	0.14
5 in. (127 mm)	5	6700C2595	CSGPP5	50/55	330/360		23/108	8/12	20/30	6/9	0.14
6 in. (152 mm)	6**	6700C2596	CSGPP6	45/55	400/500		23/153	10/15	25/35	5/7	0.17
8 in. (203 mm)	6**	6700C2596	CSGPP6	55/65	450/500		23/153	10/15	25/35	4/6	0.18
10 in. (254 mm)	7**	6700C2597	CSGPP7	55/65	450/500		23/153	8/12	25/35	3/5	0.34
12 in. (305 mm)	8**	6700C2598	CSGPP8	60/70	450/500		23/153	10/14	25/35	3/4	0.14

Data compiled using mild steel as test material.

\*Applicable for three hose machine torch only. With a two hose cutting torch, preheat pressure is set by the cutting oxygen.

\*\*For best results use ST2600FC series torches and 3/8 in. hose when using tip size 6 or larger.

\*\*\*All pressures are measured at the regulator using 25 ft. x 1/4 in. hose through tip size 5 and 25 ft. x 3/8 in. hose for tip size 6 and larger.

\*\*\*\*Oxygen consumption is 1.1 times the acetylene under neutral flame conditions.

## G-Series Series 1 Type GPP-P (Plated)



- General purpose
- Two-piece
- Medium preheat

Metal Thickness	Size	Part no.	Model no.	Cutting Oxygen *** (psig)	Cutting Oxygen (SCFH)	Preheat Oxygen * (psig)	Preheat Oxygen (SCFH)	Fuel (psig)	Fuel **** (SCFH)	Speed ipm	Kerf Width
1/4 in. (6.4 mm)	00	6700C2949	CSGPPP00	20/25	22/26	REFERENCE PREHEAT CHART ON PAGE 56	23/108	3/5	5/7	21/25	0.04
3/8 in. (9.5 mm)	0	6700C2950	CSGPPP0	25/30	45/55		23/108	3/5	8/10	20/24	0.06
1/2 in. (12.7 mm)	0	6700C2950	CSGPPP0	30/35	50/55		23/108	3/5	8/10	18/22	0.06
3/4 in. (19.1 mm)	1	6700C2951	CSGPPP1	30/35	70/80		23/108	4/6	10/12	15/20	0.08
1 in. (25.4 mm)	2	6700C2952	CSGPPP2	35/40	115/125		23/108	4/8	12/15	14/18	0.09
1 1/2 in. (38.1 mm)	2	6700C2952	CSGPPP	40/45	125/135		23/108	5/9	12/15	12/16	0.09
2 in. (50.8 mm)	3	6700C2953	CSGPPP3	40/50	150/175		23/108	5/9	14/18	10/14	0.10
2 1/2 in. (63.5 mm)	3	6700C2953	CSGPPP3	45/50	175/200		23/108	6/10	14/18	9/12	0.10
3 in. (76.2 mm)	4	6700C2954	CSGPPP4	45/50	210/250		23/108	8/12	16/20	8/11	0.12
4 in. (102 mm)	5	6700C2955	CSGPPP5	45/55	300/360		23/108	8/12	20/30	7/10	0.14
5 in. (127 mm)	5	6700C2955	CSGPPP5	50/55	330/360		23/108	8/12	20/30	6/9	0.14
6 in. (152 mm)	6**	6700C2956	CSGPPP6	45/55	400/500		23/153	10/15	25/35	5/7	0.17
8 in. (203 mm)	6**	6700C2956	CSGPPP6	55/65	450/500		23/153	10/15	25/35	4/6	0.18
10 in. (254 mm)	7**	6700C2957	CSGPPP7	55/65	450/500		23/153	8/12	25/35	3/5	0.34

## Victor Series 1 Type HPP



- Heavy preheat
- Scrap and bevel
- Hand and machine cutting

Metal Thickness	Size	Part No.	Cutting Oxygen *** (psig)	Cutting Oxygen (SCFH)	Preheat Oxygen * (psig)	Preheat Oxygen (SCFH)	Fuel (psig)	Fuel **** (SCFH)	Speed ipm	Kerf Width
1/2 in. (12.7 mm)	0	0333-0282	30/35	70/80	REFERENCE PREHEAT CHART ON PAGE 56	44/240	3/5	22/110	18/22	0.06
3/4 in. (19.1 mm)	1	0333-0283	30/35	70/80		44/240	3/6	22/110	15/20	0.08
1 in. (25.4 mm)	2	0333-0284	35/40	115/125		44/240	3/6	22/110	14/18	0.09
1 1/2 in. (38.1 mm)	2	0333-0284	40/45	125/135		44/240	4/8	22/110	12/16	0.09
2 in. (50.8 mm)	3	0333-0285	40/45	150/175		44/240	4/8	22/110	10/14	0.10
2 1/2 in. (63.5 mm)	3	0333-0285	45/50	175/200		44/240	5/9	22/110	9/12	0.10
3 in. (76.2 mm)	4	0333-0286	40/50	210/250		44/240	6/9	22/110	8/11	0.12
4 in. (102 mm)	5	0333-0287	45/55	300/360		44/240	6/9	22/110	7/10	0.14
5 in. (127 mm)	5	0333-0287	50/55	330/360		44/240	6/10	22/110	6/9	0.14
6 in. (152 mm)	6**	0333-0288	45/55	400/500		44/240	6/10	22/110	5/7	0.17
8 in. (203 mm)	6**	0333-0288	55/65	450/500		44/240	8/12	22/110	4/6	0.18
12 in. (305 mm)	8**	0333-0290	60/70	750/850		50/265	10/14	25/120	3/4	0.41
15 in. (381 mm)	10**	0333-0291	45/55	1000/1200		50/265	10/16	25/120	2/4	--
18 in. (457 mm)	12**	0333-0292	45/55	1150/1350		60/290	10/16	30/130	2/3	--

## G-Series Series 1 Type HPP

Metal Thickness	Size	Part no.	Model no.	Cutting Oxygen *** (psig)	Cutting Oxygen (SCFH)	Preheat Oxygen * (psig)	Preheat Oxygen (SCFH)	Fuel (psig)	Fuel **** (SCFH)	Speed ipm	Kerf Width
3/4 in. (19.1 mm)	1	6700C2901	CSHPP1	30/35	70/80	REFERENCE PREHEAT CHART ON PAGE 56	44/240	3/6	22/110	15/20	0.08
1 in. (25.4 mm)	2	6700C2902	CSHPP2	35/40	115/125		44/240	3/6	22/110	14/18	0.09
1 1/2 in. (38.1 mm)	2	6700C2902	CSHPP2	40/45	125/135		44/240	4/8	22/110	12/16	0.09
2 in. (50.8 mm)	3	6700C2903	CSHPP3	40/45	150/175		44/240	4/8	22/110	10/14	0.10
2 1/2 in. (63.5 mm)	3	6700C2903	CSHPP3	45/50	175/200		44/240	5/9	22/110	9/12	0.10
3 in. (76.2 mm)	4	6700C2904	CSHPP4	40/50	210/250		44/240	6/9	22/110	8/11	0.12
4 in. (102 mm)	5	6700C2905	CSHPP5	45/55	300/360		44/240	6/9	22/110	7/10	0.14
5 in. (127 mm)	5	6700C2905	CSHPP5	50/55	330/360		44/240	6/10	22/110	6/9	0.14
6 in. (152 mm)	6**	6700C2906	CSHPP6	45/55	400/500		44/240	6/10	22/110	5/7	0.17
8 in. (203 mm)	6**	6700C2906	CSHPP6	55/65	450/500		44/240	8/12	22/110	4/6	0.18
10 in. (254 mm)	7**	6700C2907	CSHPP7	55/65	450/500		23/153	5/12	25/35	3/5	0.34
12 in. (305 mm)	8**	6700C2908	CSHPP8	60/70	750/850		50/265	10/14	25/120	3/4	0.41

Data compiled using mild steel as test material.

\*Applicable for three hose machine torch only. With a two hose cutting torch, preheat pressure is set by the cutting oxygen.

\*\*For best results use ST2600FC series torches and 3/8 in. hose when using tip size 6 or larger.

\*\*\*All pressures are measured at the regulator using 25 ft. x 1/4 in. hose through tip size 5 and 25 ft. x 3/8 in. hose for tip size 6 and larger.

\*\*\*\*Oxygen consumption is 1.1 times the acetylene under neutral flame conditions.

CUTTING TIPS

## Victor Series 1 Type MTHP



- High speed machines cutting up to 8" (203.2 mm)
- Two-piece
- Medium preheat

Metal Thickness	Size	Part No.	Cutting Oxygen (psig) ***	Cutting Oxygen (SCFH)	Preheat Oxygen (psig) *	Preheat Oxygen (SCFH)	Fuel (psig)	Fuel **** (SCFH)	Speed ipm	Kerf Width
1/4 in. (6.4 mm)	00	0333-0352	85/95	68/75	30/35	23/140	8 oz +	12/65	23/30	0.05
3/8 in. (9.5 mm)	00	0333-0352	85/95	68/75	30/35	23/140	8 oz +	12/65	22/29	0.05
1/2 in. (12.7 mm)	0	0333-0353	85/95	110/120	30/35	23/140	8 oz +	12/65	20/28	0.06
3/4 in. (19.1 mm)	0	0333-0353	85/95	110/120	30/35	23/140	8 oz +	12/65	18/26	0.06
1 in. (25.4 mm)	1	0333-0354	85/95	145/160	30/35	23/140	8 oz +	12/65	17/24	0.07
1 1/4 in. (31.75 mm)	1	0333-0354	85/95	145/160	30/35	23/140	8 oz +	12/65	16/20	0.07
1 1/2 in. (38.1 mm)	1	0333-0354	85/95	145/160	30/35	23/140	8 oz +	12/65	12/16	0.07
1 1/2 in. (38.1 mm)	2	0333-0355	85/95	230/250	30/35	23/140	8 oz +	12/65	11/15	0.09
2 in. (50.8 mm)	2	0333-0355	85/95	230/250	30/35	23/140	8 oz +	12/65	10/13	0.09
2 1/2 in. (63.5 mm)	2	0333-0355	85/95	230/250	30/35	23/140	8 oz +	12/65	9/11	0.09
3 in. (76.2 mm)	3	0333-0356	85/95	285/320	30/35	23/140	8 oz +	12/65	7/10	0.11
4 in. (102 mm)	3	0333-0356	85/95	285/320	30/35	23/140	8 oz +	12/65	6/8	0.11
5 in. (127 mm)	3	0333-0356	85/95	285/320	30/35	23/140	8 oz +	12/65	5/7	0.11
6 in. (152 mm)	4	0333-0357	85/95	390/450	30/35	23/140	8 oz +	12/65	5/6	0.14
8 in. (203 mm)	4	0333-0357	85/95	390/450	30/35	23/140	8 oz +	12/65	4/6	0.14
9 in. (228.6 mm)	5	0333-0358	85/95	670/720	30/35	23/140	8 oz +	12/65	4/5	0.18
10 in. (254 mm)	5	0333-0358	85/95	670/720	30/35	23/140	8 oz +	12/65	3/5	0.18

## G-Series Series 1 Type MTHP

Metal Thickness	Size	Part No.	Cutting Oxygen (psig) ***	Cutting Oxygen (SCFH)	Preheat Oxygen (psig) *	Preheat Oxygen (SCFH)	Fuel (psig)	Fuel **** (SCFH)	Speed ipm	Kerf Width	Kerf Width
1/4 in. (6.4 mm)	00	6700C3119	CSMTHP00	85/95	68/75	30/35	23/140	8 oz +	12/65	23/30	0.05
3/8 in. (9.5 mm)	00	6700C3119	CSMTHP00	85/95	68/75	30/35	23/140	8 oz +	12/65	22/29	0.05
1/2 in. (12.7 mm)	0	6700C3120	CSMTHP0	85/95	110/120	30/35	23/140	8 oz +	12/65	20/28	0.06
3/4 in. (19.1 mm)	0	6700C3120	CSMTHP0	85/95	110/120	30/35	23/140	8 oz +	12/65	18/26	0.06
1 in. (25.4 mm)	1	6700C3121	CSMTHP1	85/95	145/160	30/35	23/140	8 oz +	12/65	17/24	0.07
1 1/4 in. (31.75 mm)	1	6700C3121	CSMTHP1	85/95	145/160	30/35	23/140	8 oz +	12/65	16/20	0.07
1 1/2 in. (38.1 mm)	1	6700C3121	CSMTHP1	85/95	145/160	30/35	23/140	8 oz +	12/65	12/16	0.07
1 1/2 in. (38.1 mm)	2	6700C3122	CSMTHP2	85/95	230/250	30/35	23/140	8 oz +	12/65	11/15	0.09
2 in. (50.8 mm)	2	6700C3122	CSMTHP2	85/95	230/250	30/35	23/140	8 oz +	12/65	10/13	0.09
2 1/2 in. (63.5 mm)	2	6700C3122	CSMTHP2	85/95	230/250	30/35	23/140	8 oz +	12/65	9/11	0.09
3 in. (76.2 mm)	3	6700C3123	CSMTHP3	85/95	285/320	30/35	23/140	8 oz +	12/65	7/10	0.11
4 in. (102 mm)	3	6700C3123	CSMTHP3	85/95	285/320	30/35	23/140	8 oz +	12/65	6/8	0.11
5 in. (127 mm)	3	6700C3123	CSMTHP3	85/95	285/320	30/35	23/140	8 oz +	12/65	5/7	0.11
6 in. (152 mm)	4	6700C3124	CSMTHP4	85/95	390/450	30/35	23/140	8 oz +	12/65	5/6	0.14
8 in. (203 mm)	4	6700C3124	CSMTHP4	85/95	390/450	30/35	23/140	8 oz +	12/65	4/6	0.14
9 in. (228.6 mm)	5	6700C3125	CSMTHP5	85/95	670/720	30/35	23/140	8 oz +	12/65	4/5	0.18
10 in. (254 mm)	5	6700C3125	CSMTHP5	85/95	670/720	30/35	23/140	8 oz +	12/65	3/5	0.18

Data compiled using mild steel as test material.

\*Applicable for three hose machine torch only. With a two hose cutting torch, preheat pressure is set by the cutting oxygen.

\*\*For best results use ST2600FC series torches and 3/8 in. hose when using tip size 6 or larger.

\*\*\*All pressures are measured at the regulator using 25 ft. x 1/4 in. hose through tip size 5 and 25 ft. x 3/8 in. hose for tip size 6 and larger.

\*\*\*\*Oxygen consumption is 1.1 times the acetylene under neutral flame conditions.

## Victor Series 1 Type 303MP



- General purpose
- Hand and machine torch cutting

Metal Thickness	Size	Part No.	Cutting Oxygen *** (psig)	Cutting Oxygen (SCFH)	Preheat Oxygen * (psig)	Preheat Oxygen (SCFH)	Fuel (psig)	Fuel **** (SCFH)	Speed ipm	Kerf Width
1/4 in. (6.4 mm)	00	0330-0187	20/25	22/26	REFERENCE PREHEAT CHART ON PAGE 56	23/108	3/5	5/7	21/25	0.04
3/8 in. (9.5 mm)	0	0330-0188	25/30	45/55		23/108	3/5	8/10	20/24	0.06
1/2 in. (12.7 mm)	0	0330-0188	30/35	50/55		23/108	3/5	8/10	18/22	0.06
3/4 in. (19.1 mm)	1	0330-0189	30/35	70/80		23/108	4/6	10/12	15/20	0.08
1 in. (25.4 mm)	2	0330-0193	35/40	115/125		23/108	4/8	12/15	14/18	0.09
1 1/2 in. (38.1 mm)	2	0330-0193	40/45	125/135		23/108	5/9	12/15	12/16	0.09
2 in. (50.8 mm)	3	0330-0194	40/45	150/175		23/108	5/9	14/18	10/14	0.10
2 1/2 in. (63.5 mm)	3	0330-0194	45/50	175/200		23/108	6/10	14/18	9/12	0.10
3 in. (76.2 mm)	4	0330-0195	45/50	210/250		23/108	8/12	16/20	8/11	0.12
4 in. (102 mm)	5	0330-0196	45/55	300/360		23/108	8/12	20/30	7/10	0.14
5 in. (127 mm)	5	0330-0196	50/55	330/360		23/108	8/12	20/30	6/9	0.14
6 in. (152 mm)	6**	0330-0197	45/55	400/500		23/153	10/15	25/35	5/7	0.17
8 in. (203 mm)	6**	0330-0197	55/65	450/500		23/153	10/15	25/35	4/6	0.18

## G-Series Series 1 Type 303MP

Metal Thickness	Size	Part no.	Model no.	Cutting Oxygen *** (psig)	Cutting Oxygen (SCFH)	Preheat Oxygen * (psig)	Preheat Oxygen (SCFH)	Fuel (psig)	Fuel **** (SCFH)	Speed ipm	Kerf Width
3/8 in. (9.5 mm)	0	6700C3037	CS1303MP0	25/30	45/55	REFERENCE PREHEAT CHART ON PAGE 56	23/108	3/5	8/10	20/24	0.06
1/2 in. (12.7 mm)	0	6700C3037	CS1303MP0	30/35	50/55		23/108	3/5	8/10	18/22	0.06
3/4 in. (19.1 mm)	1	6700C3038	CS1303MP1	30/35	70/80		23/108	4/6	10/12	15/20	0.08
1 in. (25.4 mm)	2	6700C3039	CS1303MP2	35/40	115/125		23/108	4/8	12/15	14/18	0.09
1 1/2 in. (38.1 mm)	2	6700C3039	CS1303MP2	40/45	125/135		23/108	5/9	12/15	12/16	0.09
2 in. (50.8 mm)	3	6700C3040	CS1303MP3	40/50	150/175		23/108	5/9	14/18	10/14	0.10
2 1/2 in. (63.5 mm)	3	6700C3040	CS1303MP3	45/50	175/200		23/108	6/10	14/18	9/12	0.10
3 in. (76.2 mm)	4	6700C3041	CS1303MP4	45/50	210/250		23/108	8/12	16/20	8/11	0.12
4 in. (102 mm)	5	6700C3042	CS1303MP5	45/55	300/360		23/108	8/12	20/30	7/10	0.14
5 in. (127 mm)	5	6700C3042	CS1303MP5	50/55	330/360		23/108	8/12	20/30	6/9	0.14
6 in. (152 mm)	6**	6700C3043	CS1303MP6	45/55	400/500		23/153	10/15	25/35	5/7	0.17
8 in. (203 mm)	6**	6700C3043	CS1303MP6	55/65	450/500		23/153	10/15	25/35	4/6	0.18

## Victor Series 1 Type BTMP



- High performance
- Bevel cutting

Metal Thickness	Size	Part No.	Cutting Oxygen *** (psig)	Cutting Oxygen (SCFH)	Preheat Oxygen * (psig)	Preheat Oxygen (SCFH)	Fuel (psig)	Fuel **** (SCFH)	Speed ipm	Kerf Width
1 in. (25.4 mm)	4	0333-0209	60/75	390/450	30/35	23/140	8-10	12/65	10/18	-
1 1/2 in. (38.1 mm)	4	0333-0209	60/75	390/450	30/35	23/140	8-10	12/65	8/16	-
2 in. (50.8 mm)	4	0333-0209	60/75	390/450	30/35	23/140	8-10	12/65	6/14	-
2 1/2 in. (63.5 mm)	4	0333-0209	60/75	390/450	30/35	23/140	8-10	12/65	5/12	-
3 in. (76.2 mm)	5	0333-0210	60/75	670/720	30/35	23/140	8-12	12/65	6/11	-
3 1/2 in. (89 mm)	5	0333-0210	60/75	670/720	30/35	23/140	8-12	12/65	12/65	-
4 in. (102 mm)	5	0333-0210	60/75	670/720	30/35	23/140	8-12	12/65	4/9	-
4 1/2 in. (114.3 mm)	5	0333-0210	60/75	670/720	30/35	23/140	8-12	12/65	4/8	-
5 in. (127 mm)	6	0333-0211	65/85	-	30/35	23/140	8-15	12/65	3/8	-
5 1/2 in. (139.7 mm)	6	0333-0211	65/85	-	30/35	23/140	8-15	12/65	3/7	-
6 in. (152 mm)	6	0333-0211	65/85	-	30/35	23/140	8-15	12/65	3/6	-

Data compiled using a 3 Hose Torch

Data compiled using mild steel as test material.

\*Applicable for three hose machine torch only. With a two hose cutting torch, preheat pressure is set by the cutting oxygen.

\*\*For best results use ST2600FC series torches and 3/8 in. hose when using tip size 6 or larger.

\*\*\*All pressures are measured at the regulator using 25 ft. x 1/4 in. hose through tip size 5 and 25 ft. x 3/8 in. hose for tip size 6 and larger.

\*\*\*\*Oxygen consumption is 1.1 times the acetylene under neutral flame conditions.

## Victor Series 1 Type GTB



- Gouging tip (bent)
- Removing welds

Metal Thickness	Size	Part No.	Cutting Oxygen *** (psig)	Cutting Oxygen (SCFH)	Preheat Oxygen * (psig)	Preheat Oxygen (SCFH)	Fuel (psig)	Fuel **** (SCFH)	Speed ipm	Kerf Width
1/4 - 3/4 in. (6.4 - 19.1 mm)	3	0333-0414	30/65	175/200	30/65	23/108	8/10	14/18	–	–
1/4 - 3/4 in. (6.4 - 19.1 mm)	4	0333-0415	30/65	210/250	30/65	23/108	8/10	16/20	–	–

## Victor Series 1 Type 318MP



- General purpose
- Gouging and rivet washing
- Medium preheat

Metal Thickness	Size	Part No.	Cutting Oxygen *** (psig)	Cutting Oxygen (SCFH)	Preheat Oxygen * (psig)	Preheat Oxygen (SCFH)	Fuel (psig)	Fuel **** (SCFH)	Speed ipm	Kerf Width
2 in. (50.8 mm)	3	0330-0333	40/45	150/175	REFERENCE PREHEAT CHART ON PAGE 56	23/108	5/9	14/18	10/14	0.10
2 1/2 in. (63.5 mm)	3	0330-0333	45/50	175/200		23/108	6/10	14/18	9/12	0.10
3 in. (76.2 mm)	4	0330-0335	45/50	210/250		23/108	8/12	16/20	8/11	0.12
6 in. (152 mm)	6**	0330-0336	45/55	400/500		23/153	10/15	25/35	5/7	0.17
8 in. (203 mm)	6**	0330-0336	55/65	450/500		23/153	10/15	25/35	4/6	0.18

## G-Series Series 1 Type 318MP

Metal Thickness	Size	Part no.	Model no.	Cutting Oxygen *** (psig)	Cutting Oxygen (SCFH)	Preheat Oxygen *(psig)	Preheat Oxygen (SCFH)	Fuel (psig)	Fuel **** (SCFH)	Speed ipm	Kerf Width
1 in. (25.4 mm)	2	6700C2651	CS318MP2	35/40	115/125	REFERENCE PREHEAT CHART ON PAGE 56	44/240	3/6	22/110	14/18	0.09
1 1/2 in. (38.1 mm)	2	6700C2651	CS318MP2	40/45	125/135		44/240	4/8	22/110	12/16	0.09
3 in. (76.2 mm)	4	6700C2652	CS318MP4	40/50	210/250		44/240	6/9	22/110	8/11	0.12
6 in. (152 mm)	6**	6700C2653	CS318MP6	45/55	400/500		44/240	6/10	22/110	5/7	0.17
8 in. (203 mm)	6**	6700C2653	CS318MP6	55/65	450/500		44/240	8/12	22/110	4/6	0.18
12 in. (305 mm)	8**	6700C2654	CS318MP8	60/70	750/850		50/265	10/14	25/120	3/4	0.41



CUTTING TIPS

Data compiled using mild steel as test material.

\*Applicable for three hose machine torch only. With a two hose cutting torch, preheat pressure is set by the cutting oxygen.

\*\*For best results use ST2600FC series torches and 3/8 in. hose when using tip size 6 or larger.





















\*\*\*All pressures are measured at the regulator using 25 ft. x 1/4 in. hose through tip size 5 and 25 ft. x 3/8 in. hose for tip size 6 and larger.

\*\*\*\*Oxygen consumption is 1.1 times the acetylene under neutral flame conditions.

Series 1 – LP Cutting Tips

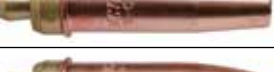
LP (Propane / Natural Gas)

Series 1 tip style, fuel gas usage and Victor equipment compatibility shown below

Type		Fuel Gas	Application
200	 	LP	<ul style="list-style-type: none"> <li>General purpose</li> <li>Hand and machine torch cutting</li> </ul>
207	 	LP	<ul style="list-style-type: none"> <li>Used for “blowing” rivets</li> <li>Popular with various railroad applications</li> </ul>
244	 	LP	<ul style="list-style-type: none"> <li>Cutting close to bulk heads</li> <li>Rivet cutting</li> </ul>
MCN	 	LP	<ul style="list-style-type: none"> <li>For application requiring extra heavy pre-heat and wide kerf</li> </ul>
GPN	 	LP	<ul style="list-style-type: none"> <li>General purpose</li> <li>Hand and machine torch cutting</li> </ul>
MTHN	 	LP	<ul style="list-style-type: none"> <li>High speed machine cutting through 10" (252 mm)</li> </ul>
HPN	 	LP	<ul style="list-style-type: none"> <li>Heavy preheat for scrap, bevel and other heavy preheat requirements</li> </ul>
BTN	 	LP	<ul style="list-style-type: none"> <li>Heavy performance bevel cutting for use with mild steel HSLA, T1 and HV-80</li> </ul>
CSN	 	LP	<ul style="list-style-type: none"> <li>A coarse splined scrap cutting tip for use with natural gas</li> </ul>
GTB	 	LP	<ul style="list-style-type: none"> <li>Gouging tip (bent)</li> <li>Removal of welds</li> </ul>

Tip packaging is color coded with reference to fuel gas usage. Other special application tips available. Contact Technical Services at 1-800-426-1888

CUTTING TIPS





## Victor Series 1 Type 200



- General purpose
- Hand and machine torch cutting

Metal Thickness	Size	Part No.	Cutting Oxygen *** (psig)	Cutting Oxygen (SCFH)	Preheat Oxygen * (psig)	Preheat Oxygen (SCFH)	Fuel (psig)	Fuel **** (SCFH)	Speed ipm	Kerf Width
3/4 in. (19.1 mm)	1	0330-0144	30/35	70/80	REFERENCE PREHEAT CHART ON PAGE 56	23/108	4/6	10/12	15/20	0.08
1 in. (25.4 mm)	2	0330-0145	35/40	115/125		23/108	4/8	12/15	14/18	0.09
1 1/2 in. (38.1 mm)	2	0330-0145	40/45	125/135		23/108	5/9	12/15	12/16	0.09
2 in. (50.8 mm)	3	0330-0146	40/50	150/175		23/108	5/9	14/18	10/14	0.10
2 1/2 in. (63.5 mm)	3	0330-0146	45/50	175/200		23/108	6/10	14/18	9/12	0.10
3 in. (76.2 mm)	4	0330-0147	45/50	210/250		23/108	8/12	16/20	8/11	0.12
4 in. (102 mm)	5	0330-0148	45/55	300/360		23/108	8/12	20/30	7/10	0.14
5 in. (127 mm)	5	0330-0148	50/55	330/360		23/108	8/12	20/30	6/9	0.14
6 in. (152 mm)	6**	0330-0149	45/55	400/500		23/153	10/15	25/35	5/7	0.17
8 in. (203 mm)	6**	0330-0149	55/65	450/500		23/153	10/15	25/35	4/6	0.18

## Victor Series 1 Type 207



- Used for "blowing" rivets
- Popular with various railroad applications

Metal Thickness	Size	Part No.	Cutting Oxygen *** (psig)	Cutting Oxygen (SCFH)	Preheat Oxygen * (psig)	Preheat Oxygen (SCFH)	Fuel (psig)	Fuel **** (SCFH)	Speed ipm	Kerf Width
3 in. (76.2 mm)	4	0330-0166	40/50	210/250	REFERENCE PREHEAT CHART ON PAGE 56	44/240	6/9	22/110	8/11	0.12

## Victor Series 1 Type 244



- Cutting close to bulk heads
- Rivet cutting

Metal Thickness	Size	Part No.	Cutting Oxygen *** (psig)	Cutting Oxygen (SCFH)	Preheat Oxygen * (psig)	Preheat Oxygen (SCFH)	Fuel (psig)	Fuel **** (SCFH)	Speed ipm	Kerf Width
1 in. (25.4 mm)	2	0330-0344	35/40	115/125	REFERENCE PREHEAT CHART ON PAGE 56	44/240	3/6	22/110	14/18	0.09
1 1/2 in. (38.1 mm)	2	0330-0344	40/45	125/135		44/240	4/8	22/110	12/16	0.09

## Victor Series 1 Type MCN



- Extra heavy preheat
- Wide kerf

Metal Thickness	Size	Part No.	Cutting Oxygen *** (psig)	Cutting Oxygen (SCFH)	Preheat Oxygen * (psig)	Preheat Oxygen (SCFH)	Fuel (psig)	Fuel **** (SCFH)	Speed ipm	Kerf Width
6 in. (152 mm)	6**	0330-0543	45/55	400/500	REFERENCE PREHEAT CHART ON PAGE 56	44/240	6/10	22/110	5/7	0.17
8 in. (203 mm)	6**	0330-0543	55/65	450/500		44/240	8/12	22/110	4/6	0.18

Data compiled using mild steel as test material.

\*Applicable for three hose machine torch only. With a two hose cutting torch, preheat pressure is set by the cutting oxygen.

\*\*For best results use ST2600FC series torches and 3/8 in. hose when using tip size 6 or larger.

\*\*\*All pressures are measured at the regulator using 25 ft. x 1/4 in. hose through tip size 5 and 25 ft. x 3/8 in. hose for tip size 6 and larger.

\*\*\*\*Oxygen consumption is 1.1 times the acetylene under neutral flame conditions.

## Victor Series 1 Type GPN



- General purpose
- Hand and machine cutting

Metal Thickness	Size	Part No.	Cutting Oxygen *** (psig)	Cutting Oxygen (SCFH)	Preheat Oxygen * (psig)	Preheat Oxygen (SCFH)	Fuel (psig)	Fuel **** (SCFH)	Speed ipm	Kerf Width
1/8 in. (3.2 mm)	000	0333-0300	20/25	12/14	REFERENCE PREHEAT CHART ON PAGE 56	23/108	3/5	5/6	24/28	0.04
1/4 in. (6.4 mm)	00	0333-0301	20/25	22/.26		23/108	3/5	5/7	21/25	0.04
3/8 in. (9.5 mm)	0	0333-0302	25/30	45/55		23/108	3/5	8/10	20/24	0.06
3/8 in. (9.5 mm)	0	0387-0172#	25/30	45/55		23/108	3/5	8/10	20/24	0.06
1/2 in. (12.7 mm)	0	0333-0302	30/35	50/55		23/108	3/5	8/10	18/22	0.06
1/2 in. (12.7 mm)	0	0387-0172#	30/35	50/55		23/108	3/5	8/10	18/22	0.06
3/4 in. (19.1 mm)	1	0333-0303	30/35	70/80		23/108	4/6	10/12	15/20	0.08
3/4 in. (19.1 mm)	1	0387-0173#	30/35	70/80		23/108	4/6	10/12	15/20	0.08
1 in. (25.4 mm)	2	0333-0304	35/40	115/125		23/108	4/8	12/15	14/18	0.09
1 in. (25.4 mm)	2	0387-0174#	35/40	115/125		23/108	4/8	12/15	14/18	0.09
1 1/2 in. (38.1 mm)	2	0333-0304	40/45	125/135		23/108	5/9	12/15	12/16	0.09
1 1/2 in. (38.1 mm)	2	0387-0174#	40/45	125/135		23/108	5/9	12/15	12/16	0.09
2 in. (50.8 mm)	3	0333-0305	40/50	150/175		23/108	5/9	14/18	10/14	0.10
2 1/2 in. (63.5 mm)	3	0333-0305	45/50	175/200		23/108	6/10	14/18	9/12	0.10
3 in. (76.2 mm)	4	0333-0306	45/50	210/250		23/108	8/12	16/20	8/11	0.12
4 in. (102 mm)	5	0333-0307	45/55	300/360		23/108	8/12	20/30	7/10	0.14
5 in. (127 mm)	5	0333-0307	50/55	330/360		23/108	8/12	20/30	6/9	0.14
6 in. (152 mm)	6**	0333-0308	45/55	400/500		23/153	10/15	25/35	5/7	0.17
8 in. (203 mm)	6**	0333-0308	55/65	450/500		23/153	10/15	25/35	4/6	0.18
10 in. (254 mm)	7**	0333-0309	55/65	450/500		23/153	8/12	25/35	3/5	0.34
12 in. (305 mm)	8**	0333-0310	60/70	450/500	23/153	10/14	25/35	3/4	0.41	

## G-Series Series 1 Type GPN

Metal Thickness	Size	Part no.	Model no.	Cutting Oxygen *** (psig)	Cutting Oxygen (SCFH)	Preheat Oxygen * (psig)	Preheat Oxygen (SCFH)	Fuel (psig)	Fuel **** (SCFH)	Speed ipm	Kerf Width
1/8 in. (3.2 mm)	000	6700C2468	CSGPN000	20/25	12/14	REFERENCE PREHEAT CHART ON PAGE 56	23/108	3/5	5/6	24/28	0.04
1/4 in. (6.4 mm)	00	6700C2469	CSGPN00	20/25	22/.26		23/108	3/5	5/7	21/25	0.04
3/8 in. (9.5 mm)	0	6700C2470	CSGPN0	25/30	45/55		23/108	3/5	8/10	20/24	0.06
1/2 in. (12.7 mm)	0	6700C2470	CSGPN00	30/35	50/55		23/108	3/5	8/10	18/22	0.06
3/4 in. (19.1 mm)	1	6700C2471	CSGPN1	30/35	70/80		23/108	4/6	10/12	15/20	0.08
1 in. (25.4 mm)	2	6700C2472	CSGPN2	35/40	115/125		23/108	4/8	12/15	14/18	0.09
1 1/2 in. (38.1 mm)	2	6700C2472	CSGPN2	40/45	125/135		23/108	5/9	12/15	12/16	0.09
2 in. (50.8 mm)	3	6700C2473	CSGPN3	40/50	150/175		23/108	5/9	14/18	10/14	0.10
2 1/2 in. (63.5 mm)	3	6700C2473	CSGPN3	45/50	175/200		23/108	6/10	14/18	9/12	0.10
3 in. (76.2 mm)	4	6700C2474	CSGPN4	45/50	210/250		23/108	8/12	16/20	8/11	0.12
4 in. (102 mm)	5	6700C2475	CSGPN5	45/55	300/360		23/108	8/12	20/30	7/10	0.14
5 in. (127 mm)	5	6700C2475	CSGPN5	50/55	330/360		23/108	8/12	20/30	6/9	0.14
6 in. (152 mm)	6**	6700C2476	CSGPN6	45/55	400/500		23/153	10/15	25/35	5/7	0.17
8 in. (203 mm)	6**	6700C2476	CSGPN6	55/65	450/500		23/153	10/15	25/35	4/6	0.18
10 in. (254 mm)	7**	6700C2477	CSGPN7	55/65	450/500		23/153	8/12	25/35	3/5	0.34
12 in. (305 mm)	8**	6700C2478	CSGPN8	60/70	450/500		23/153	10/14	25/35	3/4	0.41

CUTTING TIPS

Data compiled using mild steel as test material.

\*Applicable for three hose machine torch only. With a two hose cutting torch, preheat pressure is set by the cutting oxygen.

\*\*For best results use ST2600FC series torches and 3/8 in. hose when using tip size 6 or larger.

\*\*\*All pressures are measured at the regulator using 25 ft. x 1/4 in. hose through tip size 5 and 25 ft. x 3/8 in. hose for tip size 6 and larger.

\*\*\*\*Oxygen consumption is 1.1 times the acetylene under neutral flame conditions.

## G-Series Series 1 Type GPN (Plated)



- General purpose
- Hand and machine cutting
- Two-piece
- Medium preheat

Metal Thickness	Size	Part no.	Model no.	Cutting Oxygen *** (psig)	Cutting Oxygen (SCFH)	Preheat Oxygen * (psig)	Preheat Oxygen (SCFH)	Fuel (psig)	Fuel **** (SCFH)	Speed ipm	Kerf Width
1/8 in. (3.2 mm)	000	6700C2928	CSGPNP000	20/25	12/14	REFERENCE PREHEAT CHART ON PAGE 63	23/108	3/5	5/6	24/28	0.04
1/4 in. (6.4 mm)	00	6700C2929	CSGPNP00	20/25	22/.26		23/108	3/5	5/7	21/25	0.04
3/8 in. (9.5 mm)	0	6700C2930	CSGPNP0	25/30	45/55		23/108	3/5	8/10	20/24	0.06
1/2 in. (12.7 mm)	0	6700C2930	CSGPNP0	30/35	50/55		23/108	3/5	8/10	18/22	0.06
3/4 in. (19.1 mm)	1	6700C2931	CSGPNP1	30/35	70/80		23/108	4/6	10/12	15/20	0.08
1 in. (25.4 mm)	2	6700C2932	CSGPNP2	35/40	115/125		23/108	4/8	12/15	14/18	0.09
1 1/2 in. (38.1 mm)	2	6700C2932	CSGPNP2	40/45	125/135		23/108	5/9	12/15	12/16	0.09
2 in. (50.8 mm)	3	6700C2933	CSGPNP3	40/50	150/175		23/108	5/9	14/18	10/14	0.10
2 1/2 in. (63.5 mm)	3	6700C2933	CSGPNP3	45/50	175/200		23/108	6/10	14/18	9/12	0.10
3 in. (76.2 mm)	4	6700C2934	CSGPNP4	45/50	210/250		23/108	8/12	16/20	8/11	0.12
4 in. (102 mm)	5	6700C2935	CSGPNP5	45/55	300/360		23/108	8/12	20/30	7/10	0.14
5 in. (127 mm)	5	6700C2935	CSGPNP5	50/55	330/360		23/108	8/12	20/30	6/9	0.14
6 in. (152 mm)	6**	6700C2936	CSGPNP6	45/55	400/500		23/153	10/15	25/35	5/7	0.17
8 in. (203 mm)	6**	6700C2936	CSGPNP6	55/65	450/500		23/153	10/15	25/35	4/6	0.18
10 in. (254 mm)	7**	6700C2937	CSGPNP7	55/65	450/500	23/153	8/12	25/35	3/5	0.34	
12 in. (305 mm)	8**	6700C2938	CSGPNP8	60/70	450/500	23/153	10/14	25/35	3/4	0.41	

## Victor Series 1 Type MTHN



- High speed machine cutting through 10" (252 mm)

Metal Thickness	Size	Part No.	Cutting Oxygen *** (psig)	Cutting Oxygen (SCFH)	Preheat Oxygen * (psig)	Preheat Oxygen (SCFH)	Fuel (psig)	Fuel **** (SCFH)	Speed ipm	Kerf Width
1/4 in. (6.4 mm)	00	0333-0363	85/95	68/75	30/35	23/140	8 oz +	12/65	23/30	0.05
3/8 in. (9.5 mm)	00	0333-0363	85/95	68/75	30/35	23/140	8 oz +	12/65	22/29	0.05
1/2 in. (12.7 mm)	0	0333-0364	85/95	110/120	30/35	23/140	8 oz +	12/65	20/28	0.06
3/4 in. (19.1 mm)	0	0333-0364	85/95	110/120	30/35	23/140	8 oz +	12/65	18/26	0.06
1 in. (25.4 mm)	1	0333-0365	85/95	145/160	30/35	23/140	8 oz +	12/65	17/24	0.07
1 1/4 in. (31.75 mm)	1	0333-0365	85/95	145/160	30/35	23/140	8 oz +	12/65	16/20	0.07
1 1/2 in. (38.1 mm)	1	0333-0365	85/95	145/160	30/35	23/140	8 oz +	12/65	12/16	0.07
2 in. (50.8 mm)	2	0333-0366	85/95	230/250	30/35	23/140	8 oz +	12/65	11/15	0.09
2 1/2 in. (63.5 mm)	2	0333-0366	85/95	230/250	30/35	23/140	8 oz +	12/65	10/13	0.09
3 in. (76.2 mm)	2	0333-0366	85/95	230/250	30/35	23/140	8 oz +	12/65	9/11	0.09
4 in. (102 mm)	3	0333-0367	85/95	285/320	30/35	23/140	8 oz +	12/65	7/10	0.11
5 in. (127 mm)	3	0333-0367	85/95	285/320	30/35	23/140	8 oz +	12/65	6/8	0.11
6 in. (152 mm)	3	0333-0367	85/95	285/320	30/35	23/140	8 oz +	12/65	5/7	0.11
7 in. (177.8 mm)	4	0333-0368	85/95	390/450	30/35	23/140	8 oz +	12/65	5/6	0.14
8 in. (203 mm)	4	0333-0368	85/95	390/450	30/35	23/140	8 oz +	12/65	4/6	0.14
9 in. (228.6 mm)	5	0333-0369	85/95	670/720	30/35	23/140	8 oz +	12/65	4/5	0.18
10 in. (254 mm)	5	0333-0369	85/95	670/720	30/35	23/140	8 oz +	12/65	3/5	0.18
—	6**	0333-0370	85/95	—	30/35	23/140	8 oz +	12/65	—	—
—	8**	0333-0371	85/95	—	30/35	23/140	8 oz +	12/65	—	—

CUTTING TIPS

Data compiled using mild steel as test material.

\*Applicable for three hose machine torch only. With a two hose cutting torch, preheat pressure is set by the cutting oxygen.

\*\*For best results use ST2600FC series torches and 3/8 in. hose when using tip size 6 or larger.

\*\*\*All pressures are measured at the regulator using 25 ft. x 1/4 in. hose through tip size 5 and 25 ft. x 3/8 in. hose for tip size 6 and larger.

\*\*\*\*Oxygen consumption is 1.1 times the acetylene under neutral flame conditions.

## G-Series Series 1 Type MTHN



- High speed machine cutting
- Two-piece

Metal Thickness	Size	Part No.	Model No.	Cutting Oxygen *** (psig)	Cutting Oxygen (SCFH)	Preheat Oxygen * (psig)	Preheat Oxygen (SCFH)	Fuel (psig)	Fuel **** (SCFH)	Speed ipm	Kerf Width
1/4 in. (6.4 mm)	00	6700C3089	CSMTHN00	85/95	68/75	30/35	23/140	8 oz +	12/65	23/30	0.05
3/8 in. (9.5 mm)	00	6700C3089	CSMTHN00	85/95	68/75	30/35	23/140	8 oz +	12/65	22/29	0.05
1/2 in. (12.7 mm)	0	6700C3090	CSMTHN0	85/95	110/120	30/35	23/140	8 oz +	12/65	20/28	0.06
3/4 in. (19.1 mm)	0	6700C3090	CSMTHN0	85/95	110/120	30/35	23/140	8 oz +	12/65	18/26	0.06
1 in. (25.4 mm)	1	6700C3091	CSMTHN1	85/95	145/160	30/35	23/140	8 oz +	12/65	17/24	0.07
1 1/4 in. (31.75 mm)	1	6700C3091	CSMTHN1	85/95	145/160	30/35	23/140	8 oz +	12/65	16/20	0.07
1 1/2 in. (38.1 mm)	1	6700C3091	CSMTHN1	85/95	145/160	30/35	23/140	8 oz +	12/65	12/16	0.07
2 in. (50.8 mm)	2	6700C3092	CSMTHN2	85/95	230/250	30/35	23/140	8 oz +	12/65	11/15	0.09
2 1/2 in. (63.5 mm)	2	6700C3092	CSMTHN2	85/95	230/250	30/35	23/140	8 oz +	12/65	10/13	0.09
3 in. (76.2 mm)	2	6700C3092	CSMTHN2	85/95	230/250	30/35	23/140	8 oz +	12/65	9/11	0.09
4 in. (102 mm)	3	6700C3093	CSMTHN3	85/95	285/320	30/35	23/140	8 oz +	12/65	7/10	0.11
5 in. (127 mm)	3	6700C3093	CSMTHN3	85/95	285/320	30/35	23/140	8 oz +	12/65	6/8	0.11
6 in. (152 mm)	3	6700C3093	CSMTHN3	85/95	285/320	30/35	23/140	8 oz +	12/65	5/7	0.11
7 in. (177.8 mm)	4	6700C3094	CSMTHN4	85/95	390/450	30/35	23/140	8 oz +	12/65	5/6	0.14
8 in. (203 mm)	4	6700C3094	CSMTHN4	85/95	390/450	30/35	23/140	8 oz +	12/65	4/6	0.14
9 in. (228.6 mm)	5	6700C3095	CSMTHN5	85/95	670/720	30/35	23/140	8 oz +	12/65	4/5	0.18
10 in. (254 mm)	5	6700C3095	CSMTHN5	85/95	670/720	30/35	23/140	8 oz +	12/65	3/5	0.18
–	6**	6700C3096	CSMTHN6	85/95	–	30/35	23/140	8 oz +	12/65	–	–

## Victor Series 1 Type HPN



- n Heavy preheat
- n Strap and bevel

Metal Thickness	Size	Part No.	Cutting Oxygen *** (psig)	Cutting Oxygen (SCFH)	Preheat Oxygen * (psig)	Preheat Oxygen (SCFH)	Fuel (psig)	Fuel **** (SCFH)	Speed ipm	Kerf Width
1/2 in. (12.7 mm)	0	0333-0322	30/35	70/80	REFERENCE PREHEAT CHART ON PAGE 56	44/240	3/5	22/110	18/22	0.06
3/4 in. (19.1 mm)	1	0333-0323	30/35	70/80		44/240	3/6	22/110	15/20	0.08
1 in. (25.4 mm)	2	0333-0324	35/40	115/125		44/240	3/6	22/110	14/18	0.09
1 1/2 in. (38.1 mm)	2	0333-0324	40/45	125/135		44/240	4/8	22/110	12/16	0.09
2 in. (50.8 mm)	3	0333-0325	40/45	150/175		44/240	4/8	22/110	10/14	0.10
2 1/2 in. (63.5 mm)	3	0333-0325	45/50	175/200		44/240	5/9	22/110	9/12	0.10
3 in. (76.2 mm)	4	0333-0326	40/50	210/250		44/240	6/9	22/110	8/11	0.12
4 in. (102 mm)	5	0333-0327	45/55	300/360		44/240	6/9	22/110	7/10	0.14
5 in. (127 mm)	5	0333-0327	50/55	330/360		44/240	6/10	22/110	6/9	0.14
6 in. (152 mm)	6**	0333-0328	45/55	400/500		44/240	6/10	22/110	5/7	0.17
8 in. (203 mm)	6**	0333-0328	55/65	450/500		44/240	8/12	22/110	4/6	0.18
12 in. (305 mm)	8**	0333-0330	60/70	750/850		50/265	10/14	25/120	3/4	0.41
15 in. (381 mm)	10**	0333-0331	45/55	1000/1200		50/265	10/16	25/120	2/4	–
18 in. (457.2 mm)	12**	0333-0332	45/55	1150/1350		60/290	10/16	30/130	2/3	–

Data compiled using mild steel as test material.

\*Applicable for three hose machine torch only. With a two hose cutting torch, preheat pressure is set by the cutting oxygen.

\*\*For best results use ST2600FC series torches and 3/8 in. hose when using tip size 6 or larger.

\*\*\*All pressures are measured at the regulator using 25 ft. x 1/4 in. hose through tip size 5 and 25 ft. x 3/8 in. hose for tip size 6 and larger.

\*\*\*\*Oxygen consumption is 1.1 times the acetylene under neutral flame conditions.

## G-Series Series 1 Type HPN



- n Hand and machine torch cutting
- n Heavy preheat

Metal Thickness	Size	Part No.	Cutting Oxygen *** (psig)	Cutting Oxygen (SCFH)	Preheat Oxygen * (psig)	Preheat Oxygen (SCFH)	Fuel (psig)	Fuel **** (SCFH)	Speed ipm	Kerf Width	Kerf Width
3/4 in. (19.1 mm)	1	6700C2841	CSHPN1	30/35	70/80	REFERENCE PREHEAT CHART ON PAGE 56	44/240	3/6	22/110	15/20	0.08
1 in. (25.4 mm)	2	6700C2842	CSMTHN2	35/40	115/125		44/240	3/6	22/110	14/18	0.09
1 1/2 in. (38.1 mm)	2	6700C2842	CSMTHN2	40/45	125/135		44/240	4/8	22/110	12/16	0.09
2 in. (50.8 mm)	3	6700C2843	CSMTHN3	40/45	150/175		44/240	4/8	22/110	10/14	0.10
2 1/2 in. (63.5 mm)	3	6700C2843	CSMTHN3	45/50	175/200		44/240	5/9	22/110	9/12	0.10
3 in. (76.2 mm)	4	6700C2844	CSMTHN4	40/50	210/250		44/240	6/9	22/110	8/11	0.12
4 in. (102 mm)	5	6700C2845	CSMTHN5	45/55	300/360		44/240	6/9	22/110	7/10	0.14
5 in. (127 mm)	5	6700C2845	CSMTHN5	50/55	330/360		44/240	6/10	22/110	6/9	0.14
6 in. (152 mm)	6**	6700C2846	CSMTHN6	45/55	400/500		44/240	6/10	22/110	5/7	0.17
8 in. (203 mm)	6**	6700C2846	CSMTHN6	55/65	450/500		44/240	8/12	22/110	4/6	0.18
10 in. (254 mm)	7	6700C2847	CSMTHN7	55/65	450/500		23/153	8/12	25/35	3/5	0.34
12 in. (305 mm)	8**	6700C2848	CSMTHN8	60/70	750/850		50/265	10/14	25/120	3/4	0.41
15 in. (381 mm)	10**	6700C2849	CSMTHN10	45/55	1000/1200		50/265	10/16	25/120	2/4	–
18 in. (457.2 mm)	12**	6700C2850	CSMTHN12	45/55	1150/1350		60/290	10/16	30/130	2/3	–

## Victor Series 1 Type BTN



- Heavy performance bevel cutting for use with mild steel
- HSLA, T1 and HY-80

Metal Thickness	Size	Part No.	Cutting Oxygen *** (psig)	Cutting Oxygen (SCFH)	Preheat Oxygen * (psig)	Preheat Oxygen (SCFH)	Fuel (psig)	Fuel **** (SCFH)	Speed ipm	Kerf Width
1 in. (25.4 mm)	4	0333-0206	60/75	390/450	30/35	23/140	8-10	12/65	10/18	–
1 1/2 in. (38.1 mm)	4	0333-0206	60/75	390/450	30/35	23/140	8-10	12/65	8/16	–
2 in. (50.8 mm)	4	0333-0206	60/75	390/450	30/35	23/140	8-10	12/65	6/14	–
2 1/2 in. (63.5 mm)	4	0333-0206	60/75	390/450	30/35	23/140	8-10	12/65	5/12	–
3 in. (76.2 mm)	5	0333-0207	60/75	670/720	30/35	23/140	8-12	12/65	6/11	–
3 1/2 in. (89 mm)	5	0333-0207	60/75	670/720	30/35	23/140	8-12	12/65	12/65	–
4 in. (102 mm)	5	0333-0207	60/75	670/720	30/35	23/140	8-12	12/65	4/9	–
4 1/2 in. (114.3 mm)	5	0333-0207	60/75	670/720	30/35	23/140	8-12	12/65	4/8	–
5 in. (127 mm)	6	0333-0208	65/85	–	30/35	23/140	8-15	12/65	3/8	–
5 1/2 in. (139.7 mm)	6	0333-0208	65/85	–	30/35	23/140	8-15	12/65	3/7	–
6 in. (152 mm)	6	0333-0208	65/85	–	30/35	23/140	8-15	12/65	3/6	–

Data compiled using a 3 Hose Torch

## Victor Series 1 Type CSN



- A coarse splined scrap cutting tip
- Use with natural gas

Metal Thickness	Size	Part No.	Cutting Oxygen *** (psig)	Cutting Oxygen (SCFH)	Preheat Oxygen * (psig)	Preheat Oxygen (SCFH)	Fuel (psig)	Fuel **** (SCFH)	Speed ipm	Kerf Width
12 in. (305 mm)	8	0333-0411	60/70	750/850	REFERENCE PREHEAT CHART ON PAGE 56	50/265	10/14	25/120	3/4	0.41

Data compiled using mild steel as test material.

\*Applicable for three hose machine torch only. With a two hose cutting torch, preheat pressure is set by the cutting oxygen.

\*\*For best results use ST2600FC series torches and 3/8 in. hose when using tip size 6 or larger.

\*\*\*All pressures are measured at the regulator using 25 ft. x 1/4 in. hose through tip size 5 and 25 ft. x 3/8 in. hose for tip size 6 and larger.

\*\*\*\*Oxygen consumption is 1.1 times the acetylene under neutral flame conditions.

## Flashback Arrestors and Check Valves

Flashback arrestors and reverse flow check valves provide additional protection against flashbacks. Victor recommends the use of these devices whenever possible. Victor add-on flashback arrestors contain both a reverse flow check valve and a flashback arrestor.

Due to the high flow requirements of Victor Heavy Industry torches, it is important to use flashback arrestors that have sufficient flow capacity.

It is important to understand the difference between reverse flow check valves and flashback arrestors.

### Reverse Flow Check Valves:

Helps to prevent the reverse flow of gases from traveling past the check valve.

### Flashback Arrestors:

Prevents a flame from traveling past the flashback arrestor in the event of a flashback.

**NOTE:** The use of both regulator and torch mount flashback arrestors with heavy industry equipment requiring high gas volume is not recommended because it may cause excessive flow restriction. It is always better to place the safety devices at the rear of the torch than at the regulator in order to protect the hose.

### The Flashback Arrestor

Prevents flashback

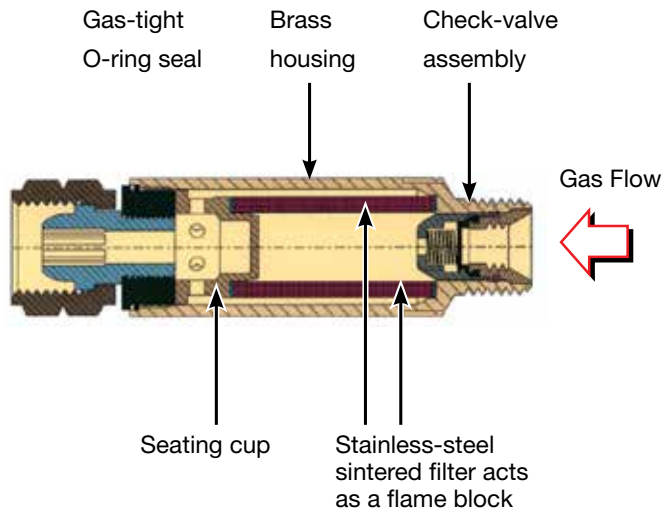

### The Check Valve

Prevents the reverse flow of gases

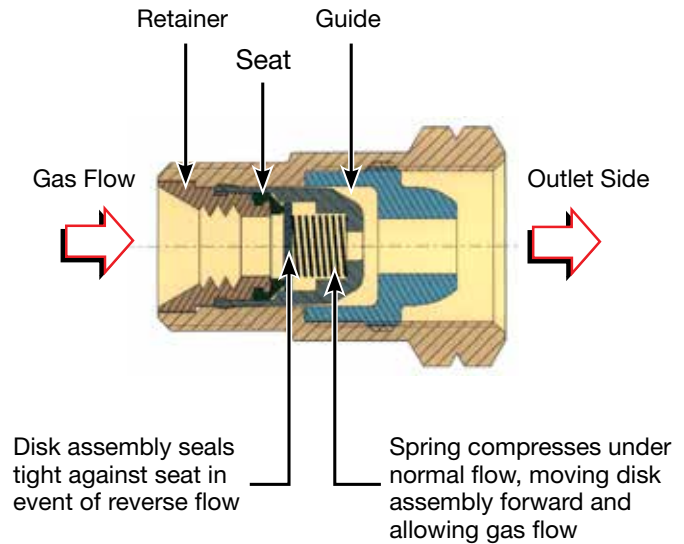

## Conversion Chart

Gas	Conversion Factor	Max. Pressure
Acetylene	1.05	15 psi
Hydrogen	3.79	30 psi
Mapp	0.82	22 psi
Methane	1.34	50 psi
Oxygen	0.95	143 psi
Propane	0.80	50 psi

## FlameBuster™ High Flow

### FBHC-O

High Flow Torch Mount



### FBHC-OR

High Flow Regulator Mount



### FBHC-OC

High Flow Torch Mount



### FBHC-ORC

High Flow Regulator Mount



### FLOW Chart - FBHC Series Flashback Arrestor

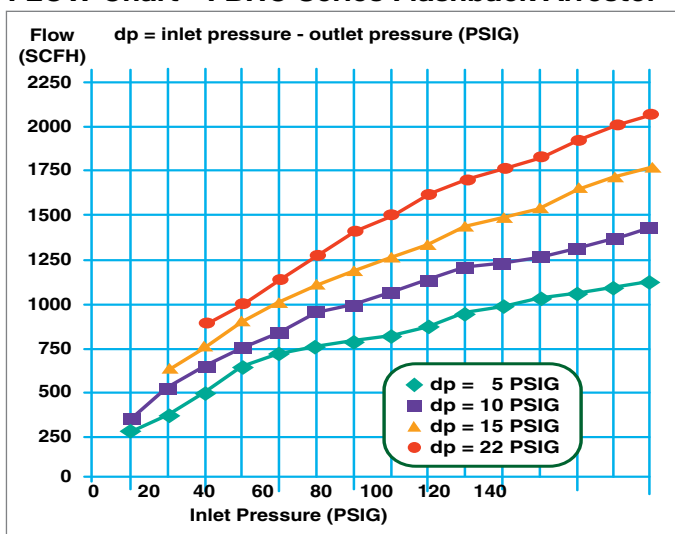

## FlameBuster™

### FB-O

Torch Mount - Oxygen



### FB-OR

Regulator Mount - Oxygen



### FB-F

Torch Mount - Fuel



### FB-FR

Regulator Mount - Fuel



### FLOW Chart - FB Series Flashback Arrestor

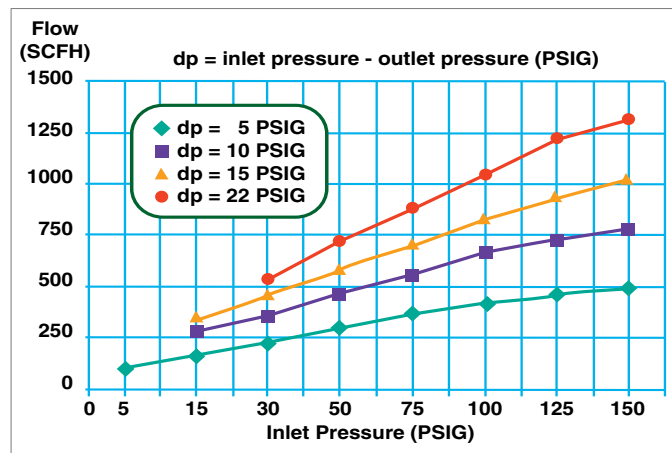

#### Ordering Information

Part No.	Model No.	Gas	Description	Connection
<b>Oxygen - Torch Mount</b>				
0657-0010	FB-O	Oxygen	Torch Mount	"B" 9/16"-18 RH (CGA 022)
<b>Oxygen - Regulator Mount</b>				
0657-0014	FB-OR	Oxygen	Regulator Mount	"B" 9/16"-18 RH (CGA 022)
<b>Fuel - Torch Mount</b>				
0657-0011	FB-F	Fuel	Torch Mount	"B" 9/16"-18 LH (CGA 023)
<b>Fuel - Regulator Mount</b>				
0657-0015	FB-FR	Fuel	Regulator Mount	"B" 9/16"-18 LH (CGA 023)
<b>Pair Packs</b>				
0656-0001	FB-1	Oxy/Fuel	Torch Mount	"B" 9/16"-18 RH/LH (CGA 022 & 023)
0656-0004	FBR-1	Oxy/Fuel	Regulator	"B" 9/16"-18 RH/LH (CGA 022 & 023)

Flow rates shown in chart are for air. To convert to other gases, multiply the air flow rate by the conversion factor listed.

Nothing can take the place of proper equipment operation. Always read, understand and follow the instructions provided with each product.

#### Ordering Information

Part No.	Model No.	Gas	Description	Connection
<b>Oxygen - Torch Mount (Torch mount models also protect hose)</b>				
0657-0076	FBHC-O	Oxygen	Torch Mount - High Flow	"B" 9/16"-18 RH (CGA 022)
0657-0077	FBHC-OC	Oxygen	Torch Mount - High Flow	"C" 7/8" - 14 RH (CGA 024)
<b>Oxygen - Regulator Mount</b>				
0657-0078	FBHC-OR	Oxygen	Regulator Mount - High Flow	"B" 9/16" - 18 RH (CGA 022)
0657-0079	FBHC-ORC	Oxygen	Regulator Mount - High Flow	"C" 7/8" - 14 RH (CGA 024)

Flow rates shown in chart are for air. To convert to other gases, multiply the air flow rate by the conversion factor listed.

Nothing can take the place of proper equipment operation. Always read, understand and follow the instructions provided with each product.

Victor® add-on flashback arrestors contain both a reverse flow check valve and a flashback arrestor

## FlameBuster™ Plus

- Flashback Arrestor with Kwik-Connect™ Coupling
- Designed to prevent flashback from torch to hose (Not for regulators)



Ordering Information	
0656-0002	FBP-1 FlameBuster Plus Torch - Pair Pack
0657-0002	FBP-0 FlameBuster Plus Torch
0657-0003	FBP-F FlameBuster Plus Torch

*Plug Assemblies available: Oxygen: 0657-0031, Fuel: 0657-0032*

## Flashback Arrestor with Kwik-Connect Coupling Components FBP-1

Ordering Information	
0657-0031	Male End Oxygen
0657-0032	Male End Fuel Gas

## Flashback Arrestors Pair Packs



Ordering Information				
Part No.	Model No.	Gas	Description	Connection
0656-0006	FBT-2	Oxy/Fuel	Torch Mount	"B" 9/16"-18 RH/LH (CGA 022 & 023)
0656-0007	FBR-2	Oxy/Fuel	Regulator Mount	"B" 9/16"-18 RH/LH (CGA 022 & 023)

## Reverse Flow Check Valves for Torches & Regulators



Ordering Information	
Torch Models	
0690-0011	CTO & CTF Torch - Check Valves Pair Pack (Oxygen & Fuel)
0690-0032	CTO Torch - Check Valve (Oxygen)
0690-0033	CTF Torch - Check Valve (Fuel)
Regulator Models	
0690-0012	CRO & CRF Regulator - Check Valves Pair Pack (Oxygen & Fuel)
0690-0034	CRO Regulator - Check Valve (Oxygen)
0690-0035	CRF Regulator - Check Valve (Fuel)

## Built-in Flash Arrestor

### Retro-Fit Kit

The retro-fit kit allows replacement of built-in flash arrestors for cutting torches without the use of Loctite® or heat

Ordering Information	
Torch/Hose Connections	
0656-0046	Includes oxygen and fuel cartridges, retainer plate and screws, hex key, and instructions

*Repair of oxy/fuel equipment, including flashback arrestor and check valve replacement, should be done by a qualified technician.*

## Vanguard™ Flashback Arrestor Replacement Cartridge



Ordering Information	
Torch/Hose Connections	
0657-0036	Torch and Torch Handle Replacement Cartridge (315FC, 100FC, J 100FC) (CST 800FC) (Both Gases)
0657-0068	Torch & Torch Handle Replacement Cartridge (H 315FC, ST 900FC, ST 1000FC, ST 2600FC) (Oxygen)
0657-0069	Torch & Torch Handle Replacement Cartridge (H 315FC, ST 900FC, ST 1000FC, ST 2600) (Fuel Gas)

*Flashback arrestor replacement cartridges include an "O" ring but does not include a replacement reverse flow check valve. Part No. 0690-0027 - 9/16" (pair).*

## Kwik-Connect

### Torch/Hose Connections



Ordering Information	
Torch/Hose Connections	
0656-0000	KC-1 Kwik Connect Pair Pack (Oxygen and Fuel)
0312-0090	KCO Kwik Connect (Oxygen)
0312-0091	KCF Kwik Connect (Fuel)





# MEET YOUR MATCH.



As someone who never settles for good enough, you deserve a regulator that's as tough as you, as sharp as you, as good as you. Now it has arrived – **EDGE 2.0**. It sets the new standard for Innovation, Performance, Ease of Use & Safety. And for the latest in cutting, meet the **Plus Series Torch and Handle**.



Find out how the best just got better. Visit [esab.com/edge2](http://esab.com/edge2).

**VICTOR**  
AN ESAB BRAND

**EDGE™ 2.0**

# // ARC GOUGING & EXOTHERMIC CUTTING





# ARCAIR® AIRPRO X4000: CARBON ARC GOUGING TORCH AND CABLE.

Arcair – the name synonymous with carbon arc gouging – introduces the AirPro X4000, a torch that takes ease of use to a new level.

Instead of using 27 lbs. of grip pressure to open the torch, the operator merely pushes a rocker switch. Compressed air already flowing through the AirPro X4000 torch pneumatically opens the torch jaws so operators can insert, adjust and remove carbons without effort.

## ARCAIR CARBONS.

The AirPro X4000 accepts 3/16- to 1/2-in. (4.7 mm-12.7 mm) pointed round, 3/8- and 5/8-in. (9.5 mm-15.8 mm) flat and 5/8-in. (15.8 mm) half-round carbons.

- Pneumatic upper arm lifts when activated by the rocker switch on the torch handle.
- Rocker switch allows insertion/adjustment of carbon and controls compressed air on/off. Latch mechanism locks "On" airflow when in use.
- No air flows through the torch or the cable without initiating the flow through the rocker switch.
- No-leak air valve saves electricity and maintenance costs of maintaining the shop air compressor.
- Elimination of the lever assembly creates a lower-profile torch for improved access.

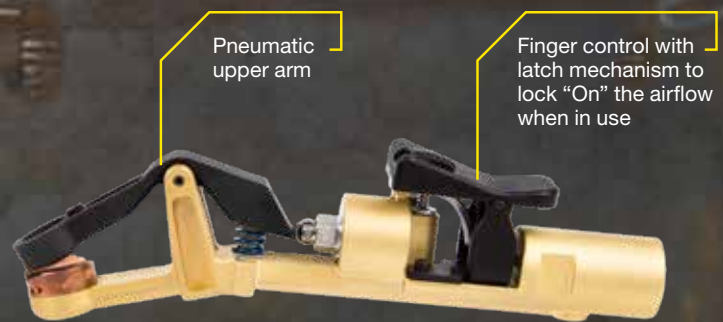

**ARCAIR**  
AN ESAB BRAND

# CONTENTS

## MANUAL GOUGING

Gouging Torches.....	167
Improved Carbon-Arc Torch Cable Boot Design .....	167
Gouging Techniques for Specific Materials .....	168
Angle-Arc® Manual Gouging Torches .....	169
K3000™ .....	170
Swivel Cable Assembly Options .....	170
K4000® .....	170
AirPro™ X4000 .....	172
Swivel Cable Assembly .....	172
Tri-Arc® Foundry Gouging Torches.....	173
Tri-Arc Torch Heads.....	173
Tri-Arc® .....	174
Swivel Cable Assembly Options .....	174
Straight Handle Manual Gouging Torches .....	175
K-5.....	175
CutSkill Manual Gouging Torches.....	175
CSK4000 .....	175
Inches of Groove per Electrode .....	176
Arcair Air Carbon-Arc Electrodes.....	177
CutSkill Electrodes .....	178
Welding Carbon Products .....	178
Arcair-Matic® N7500.....	179
All Position Travel Systems .....	180
Bug-O Travel System Packages .....	180
GULLCO Travel System Packages .....	180

## EXOTHERMIC CUTTING

Titan Travel System Packages.....	181
Arcair Titan Machine Carriage.....	182
Arcair Horizontal & Vertical Rack Bar Positioners.....	182
Horizontal Rack Bar Positioner .....	182
Vertical Rack Bar Positioner.....	182
SLICE® Exothermic Cutting System.....	183
Tips for Using SLICE® Exothermic Cutting Equipment .....	184
SLICE® Battery/Utility Pack.....	185
SLICE® Battery Ignition Source.....	185
SLICE® Industrial Pack.....	186
SLICE® Complete Pack .....	186
SLICE® Striker Assembly.....	187
SLICE® Cutting rods.....	187

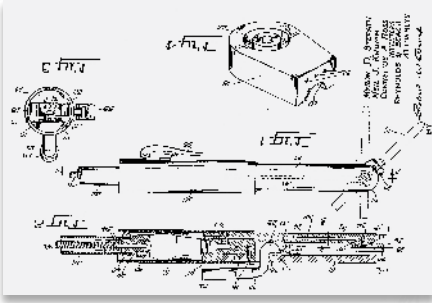

**1949**

- Myron Stepath invents CAC-A cutting and gouging process.
- Stepath founds Arcair Co.
- Introduces G-3 cutting and gouging torch.



**1956**

Introduces H-5 cutting and gouging torch.



**1961**

Arcair relocates manufacturing to Lancaster, Ohio.

**1968**

Introduces K-3 cutting and gouging torch.

**1972**

Introduces Underwater Cutting and Welding Torch.



**1974**

Myron Stepath retires.



**1980s**

SLICE® torch introduced, allowing for portable and quick cutting solutions for fire and rescue operations.

# ARCAIR IS SYNONYMOUS WITH **CARBON ARC GOUGING**

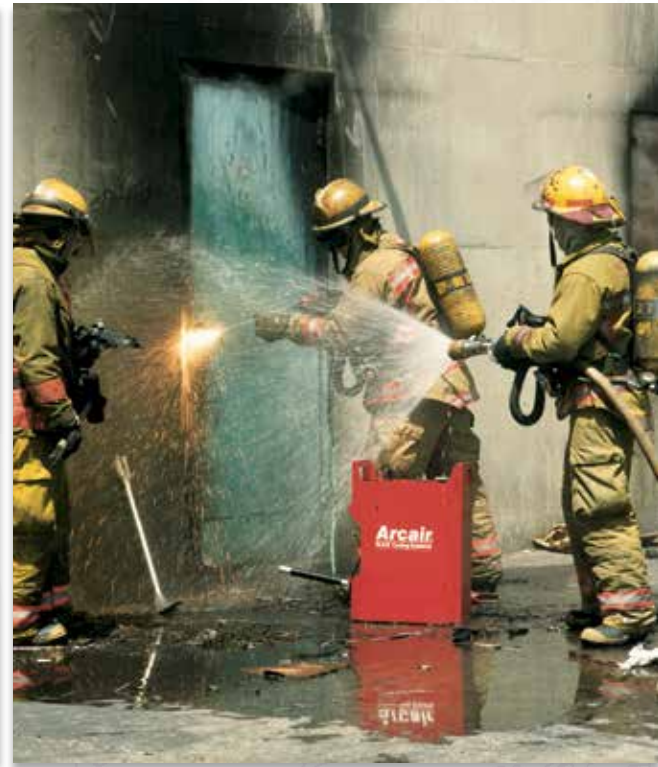

**1983**  
Introduces K4000®  
cutting and gouging torch.

**1989**

Arcair relocated to Wichita, Kansas;  
combines manufacturing with Tweco.

**2004**

Arcair relocates to  
Denton, Texas combines  
manufacturing with Victor.

**2011**

Introduces Arcair-Matic®  
N7500 Automated  
gouging System.

**2014**

Arcair becomes  
An ESAB Brand

**2018**

Introduces AirPro X4000  
gouging torch and  
cable assembly with  
the industry's first ever  
pneumatic arm.



MYRON D.  
NEIL J. K.  
CORNELIUS  
REYNOLDS

Fig. 3

## Gouging Torches

### Improved Torch Air Flow

- More efficient use of air supply
- Improved metal removal

### Four Hole Head Assembly

- Optimizes air flow to the arc
- Efficiently cleans slag from groove edge

### Air Assist Positive Air Shut-Off

- Minimizes air supply unit cycling on and off
- Allows torch usage when air supply is marginal

### Improved Cable Electrical Conduction

- Improves cable service life
- Decreases heat build up in cable and torch

### Superior Outer Cable Cover

- Durable cover for improved cable life in a harsh environment
- Resists breakdown due to exposure to heat produced by gouging

### Insulated Connection Boot & Hook-Up Kit

- Makes for easy torch hook-up
- Virtually eliminates the possibility of arcing when contacting electrically hot parts

## Improved Carbon-Arc Torch Cable Boot Design

### Patented Two-Piece Boot Design

- Molded from a hard nylon reinforced fiber polymer made to withstand the substantial abuse in shop and field applications

### Helps Prevent Accidental Arcing

- No chance of the “boot” pulling away from the power connection as seen with prior “boot” design

### Ease of Replacement in the Field

- Threaded screws holds the two halves together and can be loosened with a standard straight blade screwdriver

### Available in Two (2) Different Molded “Boot” Housing Configurations

- Conventional Boot (Part No. 94-105-032)
  - Accepts one 4/0 welding cable from the power supply and one 3/4 in. (19 mm) diameter air hose assembly providing current and compressed air
- Quick-Connect Hook-Up Kit (Part No. 94-463-046)
  - Twist lock-style power connection and air hose extending from the rear of the torch cable
- This option allows the operator to connect or disconnect the incoming power lead and air line quickly and easily

Angle-Arc®  
Gouging Torches



Straight Handle  
Gouging Torches



Tri-Arc®  
Gouging Torches



Conventional  
Replacement Part No. 94-105-032



Quick-Connect Hook-Up Kit  
Replacement Part No. 94-463-046

**NOTE:** Replacement Boots will fit onto all Arcair manual hand torch cable assemblies having an amperage range of 1000 Amps or less.



**THE “BEST” JUST GOT BETTER.**

Help prevent accidental arcing in your workplace.



## Gouging Techniques for Specific Materials

### Carbon Steel & Low Alloy Steel (such as ASTM A514 & A517) & Stainless Steel

- Use DC electrodes with DCEP (electrode positive). AC electrodes with an AC transformer can be used, but for this application, AC is only half as efficient as DC.

### Cast Iron Including Malleable & Ductile Iron (nodular)

- Use 1/2 in. (12.7 mm) or larger diameter CCDC electrodes at the highest rated amperage. Use an angle of 70° off the workpiece and the depth of gouge should not exceed 1/2 in. (12.7 mm) per pass

### Copper Alloys (copper content 60% and under)

- Use CCDC electrodes with DCEN (electrode negative) at the electrode's highest amperage rating

### Aluminum Bronze & Aluminum Nickel Bronze (naval propeller alloy)

- Use CCDC electrodes with DCEN (electrode negative) at the electrode's highest amperage rating

### Nickel Alloys (nickel content over 80% of mass)

- Use CCAC electrodes with AC current

### Nickel Alloys (nickel content under 80% of mass)

- Use CCDC electrodes with DCEP (electrode positive) at the electrode's highest amperage rating

### PRINCIPLES OF AIR CARBON ARC

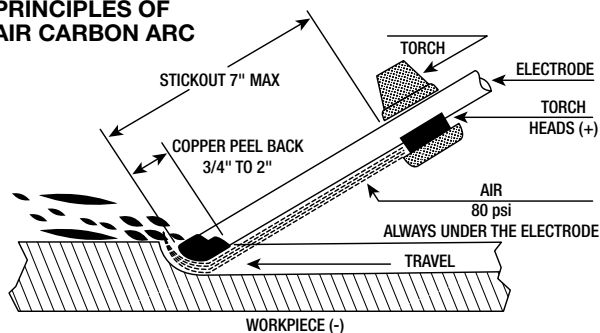

### Magnesium Alloys

- Use CCDC electrodes with DCEP (electrode positive) and prior to welding, wire brush the groove

### Aluminum

- Use CCDC electrodes with DCEP (electrode positive).
- You must brush with a stainless wire brush before welding. Electrode stick-out (length of electrode between torch and workpiece) should not exceed 3 in. (76.2 mm)

### Titanium, Zirconium, Hafnium, & Their Alloys

- Do not cut or gouge to prepare for welding or remelting unless you mechanically remove the surface layer from the cut/gouge surface

NOTE – If you preheat for welding, preheat for gouging.

### Current Requirements

Electrode	1/8 in. (3.2 mm)	5/32 in. (4.0 mm)	3/16 in. (4.8 mm)	1/4 in. (6.4 mm)	5/16 in. (7.9 mm)	3/8 in. (9.5 mm)	1/2 in. (13 mm)	5/8 in. (16 mm)	3/4 in. (19 mm)	1 in. (25 mm)	3/8 in. (9.5 mm) Flat	5/8 in. (16 mm) Flat
Minimum amps DC	60	90	200	300	350	450	800	1000	1250	1600	250	300
Maximum amps DC	90	150	250	400	450	600	1000	1250	1600	2200	450	500
Minimum amps AC	–	–	200	300	–	350	–	–	–	–	–	–
Maximum amps AC	–	–	250	400	–	450	–	–	–	–	–	–

### Gouging Torch Selection Guide

Copperclad Electrodes	Amperage Range					Recommended	Alternate
	90 – 450	450 – 1000	1000 – 1400	1400 – 2000	2000 – 2400		
1/8 in. - 3/8 in. Round (3.2 mm - 9.5 mm) 3/8 in. & 5/8 in. Flats (9.5 mm & 15.9 mm)	████████████████████					K3000	–
5/32 in. – 1/2 in. Round (4.0 mm – 12.7 mm) 3/8 in. & 5/8 in. Flats (9.5 mm & 15.9 mm)	████████████████████					AirPro X4000	K4000
5/16 in. - 5/8 in. Round (7.9 mm - 15.9 mm)	████████████████████					K-5	Tri-Arc, AirPro X4000, K4000
5/16 in. – 1 in. Round (7.9 mm – 25.4 mm)	████████████████████					Tri-Arc	–

### Which Torch Is Right For You?

Torch Model	Amperage (Maximum)	Swivel Cable	Swivel Cable Lengths	Air-Cooled Water-Cooled	Handle Design	Body/Upper Arm Construction	Application	Special Features
K3000	600	360°	7 ft & 10 ft (2 m & 3 m)	Air-Cooled	Small & Ergonomic	Brass	Medium Duty	All brass torch parts with a copper head assembly having 4-hole design
K4000	1000	360°	7 ft & 10 ft (2 m & 3 m)	Air-Cooled	Small & Ergonomic	Brass	Heavy Duty	All brass torch parts with a copper head assembly having 4-hole design
AirPro X4000	1000	360°	7 ft & 10 ft (2 m & 3 m)	Air-Cooled	Small & Ergonomic	Brass	Heavy Duty	All brass torch parts with a copper head assembly having 4-hole design, pneumatically operated upper arm
K-5	1250	340°	7 ft & 10 ft (2 m & 3 m)	Air-Cooled	Straight	Brass	Heavy Duty	All brass torch parts with a copper head assembly having 4-hole design
Tri-Arc	2200	340°	7 ft & 10 ft (2 m & 3 m)	Air-Cooled & Water-Cooled	Straight	Copper	Heavy Duty	Versatility with three (3) different head assemblies to choose from to meet any metal removal application

## Angle-Arc® Manual Gouging Torches

### Natural 15° Torch Angle

- Greater operator comfort

### Durable Front Insulators

- High impact and heat resistant protecting the torch metal parts

### 360° Swivel Cable

- Less cable twist
- Less strain on operator

### Positive Grip Handle

- Greater operator feel and ease in positioning the torch

### Reduced Weight

- Optimum cable and torch weight to minimize fatigue

### High Quality Cable Hose

- Best quality cable hose offers high heat and abrasion resistance
- Non-conductive

MANUAL GOUGING

K3000



K4000

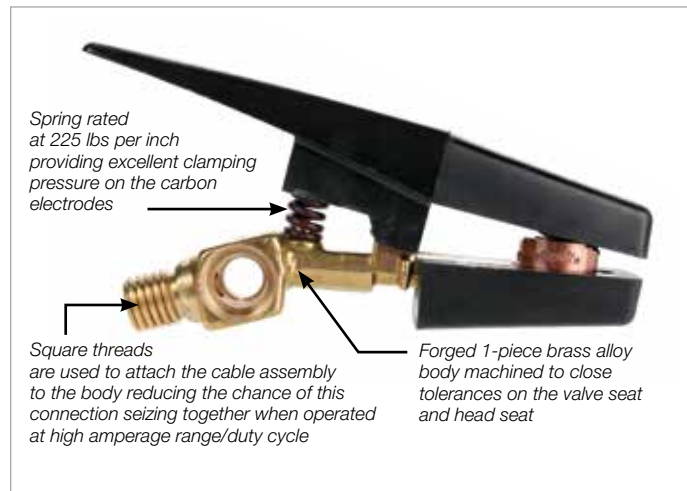

**Heavy-duty insulators, lever and handle** that are all made from fiberglass reinforced thermoset polyester molding compound to withstand the heat and be impact resistant

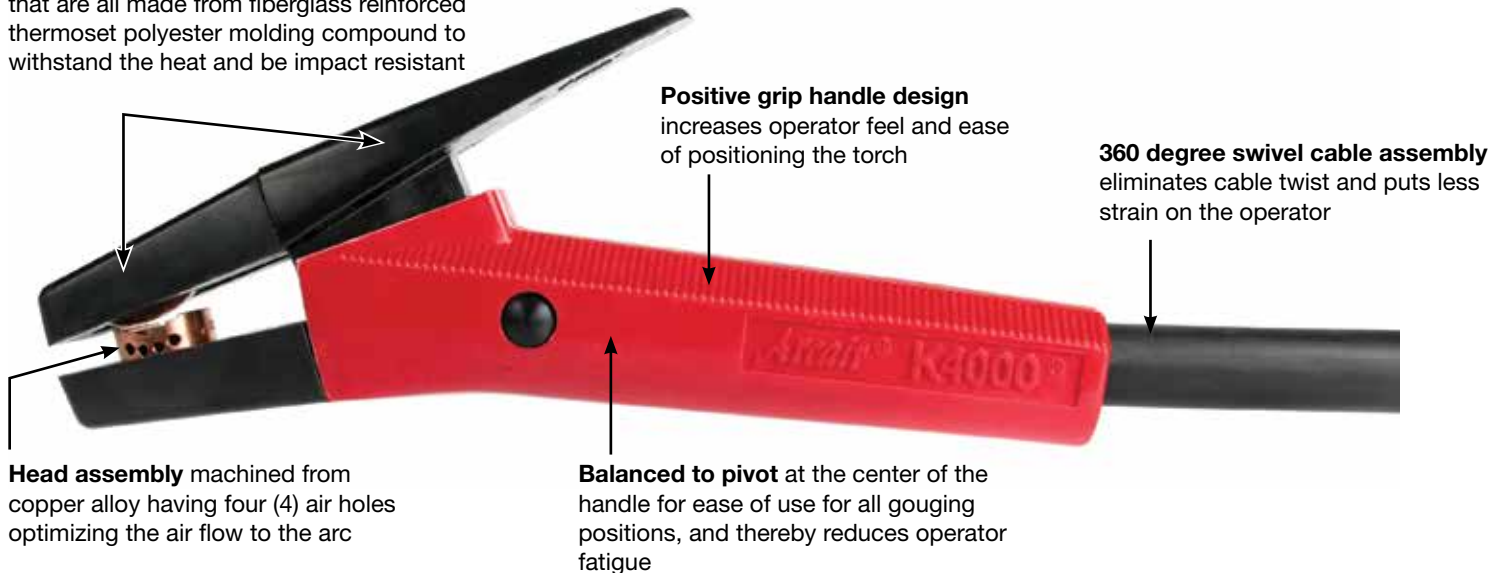

## K3000™

Medium Duty - General repair and maintenance jobs such as mining, construction, and all types of metal fabrication.



### Amperage Range

- 90 – 600 amps

### Electrode Size

- Pointed – 1/8 in. – 3/8 in. round (3.2 mm – 9.5 mm)
- Jointed - 5/16 in. – 3/8 in. round (7.9 mm – 9.5 mm)
- Flat – 3/8 in. and 5/8 in. (9.5 mm – 15.9 mm)
- Half Round – 5/8 in. (15.9 mm)

### Air Requirements

- psi – 80
- kg/cm<sup>2</sup> – 5.6
- cfm – 22
- l/min – 624

Ordering Information	
01065001	Torch Only
61065006	Torch w/7 ft (2.1 m) 360° Swivel Cable
61065002	Torch w/7 ft (2.1 m) 360° Swivel Cable & Insulated Hook-Up Kit
61065007	Torch w/10 ft (3 m) 360° Swivel Cable
61065003	Torch w/10 ft (3 m) 360° Swivel Cable & Insulated Hook-Up Kit

## K4000®

Heavy Duty - Heavy metal removal applications such as weld preparations in pressure vessel shops and shipyards.



### Amperage Range

- 90 – 1000 amps

### Electrode Size

- Pointed – 5/32 in. – 1/2 in. round (4.0 mm – 12.7 mm)
- Jointed – 5/16 in. – 1/2 in. round (7.9 mm – 12.7 mm)
- Flat – 3/8 in. and 5/8 in. (9.5 mm – 15.9 mm)
- Half Round – 5/8 in. (15.9 mm)

### Air Requirements

- psi – 80
- kg/cm<sup>2</sup> – 5.6
- cfm – 25
- l/min – 708

Ordering Information	
01082002	Torch Only
61082008	Torch w/7 ft (2.1 m) 360° Swivel Cable
61082006	Torch w/7 ft (2.1 m) 360° Swivel Cable & Insulated Hook-Up Kit
61082009	Torch w/10 ft (3 m) 360° Swivel Cable
61082007	Torch w/10 ft (3 m) 360° Swivel Cable & Insulated Hook-Up Kit

## Swivel Cable Assembly Options

K3000 360° Swivel Cable



K4000 360° Swivel Cable



Ordering Information		
K3000	K4000	
70088107	70084207	7 ft (2.1 m) 360° Swivel Cable Assembly
70088110	70084210	10 ft (3 m) 360° Swivel Cable Assembly

## AirPro™ X4000 - Pneumatic Gouging Torch & Cable Assembly

### Easy to Load

- Uses compressed air to raise and lower the upper arm; no force required to load/unload electrodes

### Simple Operation

- To gouge, press the rocker switch and slide lock forward to lock in place to begin the airflow through the torch assembly; simply slide the lock back and release the rocker switch to stops

### No Leaks

- Positive air valve to eliminate compressed air from leaking

### Positive Grip Handle

- Greater operator feel and ease in positioning the torch

### Durable Front Insulators

- High impact and heat resistance protecting the torch metal parts



**Rocker switch** allowing the insertion/adjustment of the carbon electrode and compressed air on/off; no air flow through the torch and cable assembly without initiating flow through the rocker switch

**Pneumatically operated upper arm** for ease of inserting/adjusting the carbon electrode in the torch head assembly

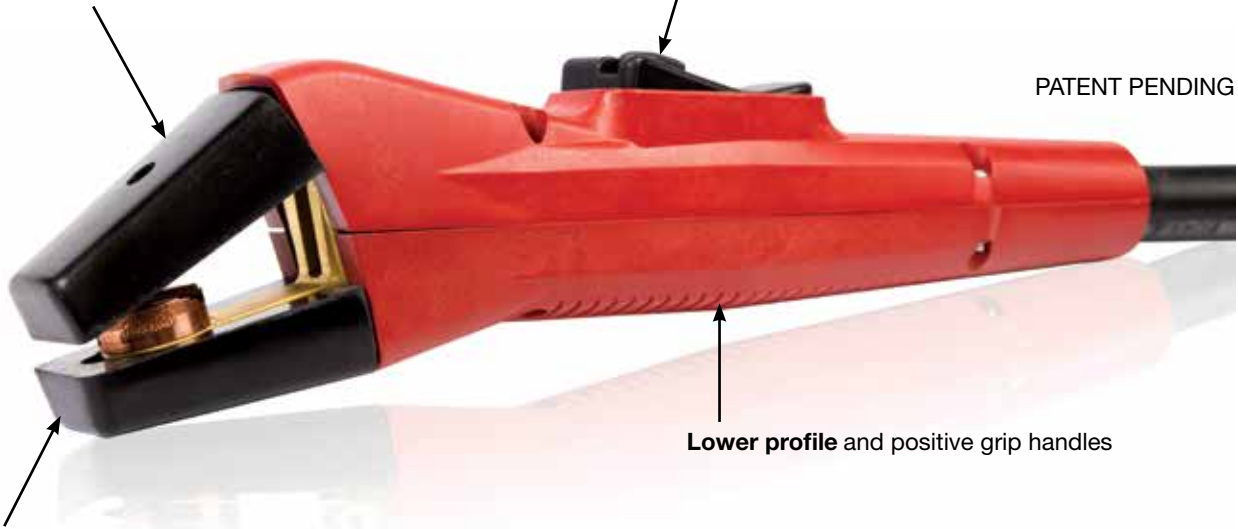

PATENT PENDING

**Lower profile** and positive grip handles

**High impact**, heat resistant insulators

## AirPro™ X4000

Introducing the next generation air carbon-arc metal removal torch and cable assembly, AirPro X4000. The unique, patent-pending, pneumatically operated upper arm and air valve design eliminates air leakage through the torch and cable when turned off, making this torch assembly the best in the market.



Ideal for the following industries:

- Ship and Offshore Yards
- Civil Construction
- Pipe Construction
- Repair and Maintenance
- Heavy Fabrication
- Industrial and General Fabrication
- Mining
- Steel Erectors

### Amperage Range

- 90 – 1000 amps

### Electrode Size

- Pointed – 3/16 in. – 1/2 in. round (4.7 mm – 12.7 mm)
- Jointed – 5/16 in. – 1/2 in. round (7.9 mm – 12.7 mm)
- Flat – 3/8 in. and 5/8 in. (9.5 mm – 15.9 mm)
- Half Round – 5/8 in. (15.9 mm)

### Air Requirements

- psi – 80
- kg/cm2 – 5.6
- cfm – 25
- l/min – 708

### Ordering Information

01084002	AirPro X4000 Torch Only
61084008	AirPro X4000 Torch & Cable Assembly 7 ft. (2.1 m) – 360° Swivel
61084006	AirPro X4000 Torch & Cable Assembly 7 ft. (2.1 m) – 360° Swivel & Insulated Hook-up Kit
61084009	AirPro X4000 Torch & Cable Assembly 10 ft. (3 m) – 360° Swivel
61084007	AirPro X4000 Torch & Cable Assembly 10 ft. (3 m) – 360° Swivel & Insulated Hook-up Kit

## Swivel Cable Assembly



### Ordering Information

70084407	7 ft (2.1 m) 360° Swivel Cable
70084410	10 ft (3 m) 360° Swivel Cable
94463046	Quick Connect Hook-Up Kit

## Tri-Arc® Foundry Gouging Torches

### Three Torches in One

- Designed for foundry applications, defect removal, general purpose applications, and padwashing by just changing head assemblies

### High Impact, Heat Resistant Insulators

- Provides protection for the torch metal parts

### Forged Body

- Provides cooler operation, improved air flow and greater current ratings

### Powerful Insulated Coil Spring & High Strength Upper Arm

- Insures positive electrode contact at all angles

### Better Balance

- Streamline design and high strength fluted handles reduce operator fatigue

### Easy Cable Installation

- No need to disassemble the torch, just slide the sleeve from the rear of the handle

**Heavy-duty insulators**, lever and handle that are all made from fiberglass reinforced thermoset polyester molding compound to withstand the heat and be impact resistant

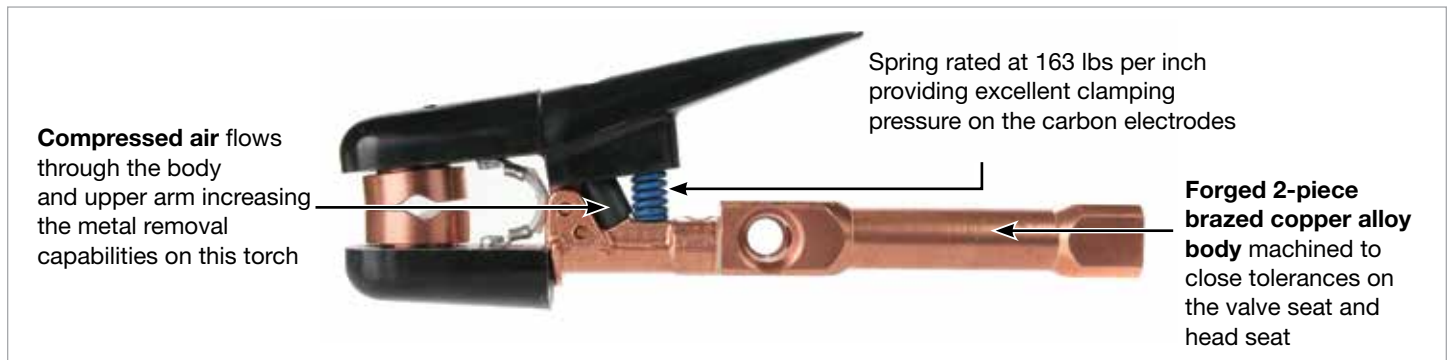

## Tri-Arc Torch Heads

### Defect Removal Heads

- For removal of defects and fine removal application
- Accepts electrode diameters – 3/8 in. (9.5 mm) through 3/4 in. (19.05 mm)



### General Purpose Cleaning Heads

- For removal of defects, fin removal, padwashing, and piercing applications
- Accepts electrode diameters – 1/2 in. (12.7 mm) through 1 in. (25.4 mm)



### Padwashing Heads

- For padwashing applications only
- Heads are fixed on a 35° work angle
- Accepts electrode diameters – 1/2 in. (12.7 mm) through 3/4 in. (19.05 mm)



## Tri-Arc®

Foundry - General foundry work, pad washing, defect, nails, sprue and interior work



### Amperage Range

- 450 – 2200 amps

### Electrode Size

- 5/16 in. – 1 in. Round (7.9 mm – 25.4 mm)

### Air Requirements

- psi – 80
- kg/cm<sup>2</sup> – 5.6
- cfm – 33
- l/min – 934

Ordering Information		
No Heads in Torch		Electrode Size
02991411	Torch Only	–
62991417	Torch & 7 ft (2.1 m) Cable	–
No Heads in Torch – No Valve		Electrode Size
02991426	Torch Only	–
Defect Removal Heads		Electrode Size
94378298	Replacement Heads	3/8 in. (9.5 mm) thru 3/4 in. (19.05 mm)
Padwashing Heads		Electrode Size
94378286	Replacement Heads	1/2 in. (12.7 mm)
94378289	Replacement Heads	5/8 in. (15.9 mm)
94378283	Replacement Heads	3/4 in. (19.05 mm)
General Purpose Cleaning Heads		Electrode Size
94378267	Replacement Heads	1/2 in. (12.7 mm)
94378270	Replacement Heads	5/8 in. (15.9 mm)
94378273	Replacement Heads	3/4 in. (19.05 mm)
94378343	Replacement Heads	1 in. (25.4 mm)

Note: The cable assembly that comes standard on the assemblies is Part No. 74143607, 7 ft (2.1 m) long and rated for 1600 amperes maximum.

## Swivel Cable Assembly Options



MANUAL  
GOUGING

Ordering Information		
7 ft (2.1 m)	10 ft (3 m)	
74143607	74143610	Std. Duty - 340° Swivel Cable Assembly
74161907	–	E-H-D 340° Swivel Cable Assembly
74085207	74085210	Water-Cooled Cable Assembly – Non-Swivel

K-5 Swivel Cable



Ordering Information	
70128507	7 ft (2.1 m) 340° Swivel Cable Assembly
70128510	10 ft (3 m) 340° Swivel Cable Assembly

## Straight Handle Manual Gouging Torches

### Reliable Torch Design

- Market leader for over 60+ years
- Greater operator comfort

### Accepts a Wide Range of CCDC Gouging Electrodes

- 5/16 in. (7.9 mm) - through 5/8 in. (15.9 mm) round

### Durable Front Insulators

- High impact and heat resistant protecting the torch metal parts

### Swivel Cable

- Less cable twist
- Less strain on the operator

### High Quality Cable Hose

- Best quality cable hose offers high heat and abrasion resistance
- Non-conductive

### Rugged Construction Overall

- Can withstand harsh environments

## K-5

Extra Heavy-Duty - Heavy metal removal applications such as weld preparations in pressure vessel shops, shipyards and defect removal in foundries.



### Amperage Range

- 450 – 1250 amps

### Electrode Size

- Pointed – 5/16 in. – 1/2 in. round (7.9 mm – 12.7 mm)
- Jointed – 5/16 in. – 5/8 in. round (7.9 mm – 15.9 mm)
- Half Round – 5/8 in. (15.9 mm)

### Air Requirements

- psi – 80
- kg/cm<sup>2</sup> – 5.6
- cfm – 30
- l/min – 850

Ordering Information	
01104003	Torch Only
61104007	Torch w/7 ft (2.1 m) 360° Swivel Cable
61104008	Torch w/10 ft (3 m) 360° Swivel Cable

## CutSkill Manual Gouging Torches

### Natural 15° Torch Angle

- Greater operator comfort

### Durable Front Insulators

- High impact and heat resistant protecting the torch metal parts

### 360° Swivel Cable

- Less cable twist
- Less strain on operator

### Positive Grip Handle

- Greater operator feel and ease in positioning the torch

### Reduced Weight

- Optimum cable and torch weight to minimize fatigue

### High Quality Cable Hose

- Best quality cable hose offers high heat and abrasion resistance
- Non conductive

## CSK4000

Heavy-Duty - Heavy metal removal applications such as weld preparations in pressure vessel shops and shipyards.



### Electrode Size

- Pointed – 5/32 in. – 1/2 in. round (4.0 mm – 12.7 mm)
- Jointed - 5/16 in. – 1/2 in. round (7.9 mm – 12.7 mm)
- Flat – 3/8 in. and 5/8 in. (9.5 mm – 15.9 mm)
- Half Round – 5/8 in. (15.9 mm)

### Air Requirements

- Maximum Amperage – 1000 amps
- Compressed Air – 80 psi (5.6 kg/cm<sup>2</sup>)
- Compressed Air Flow Rate – 28 cfm (0.79 m<sup>3</sup>/min)
- Torch and Cable Weight: 5.4 lbs (2.4 kg)

Ordering Information	
01088000	Torch Only
61088007	Torch & 7 ft (2.1 m) Cable Assembly
61088010	Torch & 10 ft (3 m) Cable Assembly
70088007	7 ft (2.1 m) Cable Assembly
70088010	10 ft (3 m) Cable Assembly



## Inches of Groove per Electrode

Pointed Copperclad DC Electrodes						
Groove Depth	5/32 in. x 12 in. (4.0 mm x 30.5 cm)	3/16 in. x 12 in. (4.8 mm x 30.5 cm)	1/4 in. x 12 in. (6.5 mm x 30.5 cm)	5/16 in. x 12 in. (8.0 mm x 30.5 cm)	3/8 in. x 12 in. (9.5 mm x 30.5 cm)	1/2 in. x 14 in. (12.7 mm x 35.6 cm)
1/8 in. (3.2 mm)	65 in. (165 cm)	70 in. (178 cm)	81 in. (206 cm)	NR	NR	NR
5/32 in. (4.0 mm)	57 in. (145 cm)	65 in. (165 cm)	70 in. (178 cm)	81 in. (206 cm)	NR	NR
3/16 in. (4.8 mm)	NR	57 in. (145 cm)	66 in. (168 cm)	72 in. (183 cm)	82 in. (208 cm)	NR
1/4 in. (6.4 mm)	NR	46 in. (117 cm)	58 in. (147 cm)	66 in. (168 cm)	72 in. (183 cm)	112 in. (285 cm)
5/16 in. (8.0 mm)	NR	20 in. (51 cm) – 2P	46 in. (117 cm)	58 in. (147 cm)	59 in. (150 cm)	100 in. (254 cm)
3/8 in. (9.5 mm)	NR	12 in. (30 cm) – 2P	24 in. (61 cm) – 2P	47 in. (119 cm)	59 in. (150 cm)	88 in. (224 cm)
1/2 in. (12.7 mm)	NR	NR	14 in. (36 cm) – 2P	26 in. (66 cm) – 2P	47 in. (119 cm)	73 in. (185 cm)
5/8 in. (15.9 mm)	NR	NR	NR	16 in. (41 cm) – 2P	26 in. (66 cm) – 2P	57 in. (145 cm)
3/4 in. (19.05 mm)	NR	NR	NR	NR	16 in. (41 cm) – 2P	43 in. (109 cm)
7/8 in. (22.0 mm)	NR	NR	NR	NR	NR	35 in. (89 cm) – 2P
1 in. (25.4 mm)	NR	NR	NR	NR	NR	28 in. (71 cm) – 2P

Note: All figures derived from gouging mild steel under laboratory conditions. Field results may vary due to type of metal, power source, compressed air supply, operators experience and other parameters.

NR = Not Recommended

2P = Two (2) Passes

Jointed Copperclad DC Electrodes			
Groove Depth	5/16 in. x 14 in. (7.9 mm x 35.6 cm)	3/8 in. x 17 in. (9.5 mm x 43.2 cm)	1/2 in. x 17 in. (12.7 mm x 43.2 cm)
5/32 in. (4.0 mm)	160 in. (406 cm)	NR	NR
3/16 in. (4.8 mm)	142 in. (361 cm)	206 in. (523 cm)	NR
1/4 in. (6.4 mm)	125 in. (318 cm)	172 in. (437 cm)	260 in. (660 cm)
5/16 in. (7.9 mm)	112 in. (284 cm)	150 in. (310 cm)	188 in. (478 cm)
3/8 in. (9.5 mm)	84 in. (213 cm)	136 in. (345 cm)	157 in. (399 cm)
1/2 in. (12.7 mm)	72 in. (183 cm) – 2P	103 in. (262 cm)	140 in. (356 cm)
5/8 in. (15.9 mm)	48 in. (122 cm) – 2P	75 in. (191 cm) – 2P	102 in. (259 cm)
3/4 in. (19.05 mm)	NR	57 in. (145 cm) – 2P	90 in. (229 cm)
7/8 in. (22.0 mm)	NR	NR	80 in. (203 cm)
1 in. (25.4 mm)	NR	NR	72 in. (183 cm)

Note: All figures derived from gouging mild steel under laboratory conditions. Field results may vary due to type of metal, power source, compressed air supply, operators experience and other parameters.

NR = Not Recommended

2P = Two (2) Passes

## Arcair Air Carbon-Arc Electrodes

Designed Specifically for the Air Carbon-Arc Process

- Contain a precise formulated blend of carbon and graphite
- The most efficient metal removal performance in today's market
- Superior metal removal rates, cool operation, and uniform diameters

Ideal for a Broad Range of Applications

- Creating u-grooves for weld joint
- Removing old welds
- Gouging out cracks
- Cleaning and repairing castings
- Removing hard surface material
- Rough machining

Pointed Copperclad DC Electrodes		
Part No.	Description	Application
22023003	1/8 in. (3.2 mm) x 12 in. (30.5 cm) CCDC Pointed*	A standard, all-purpose gouging electrode. Its controlled copper coating improves electrical conductivity (for more efficient, cooler operation) and helps maintain electrode diameter at the point of the arc.
22983003	5/32 in. (4.0 mm) x 12 in. (30.5 cm) CCDC Pointed	
22033003	3/16 in. (4.8 mm) x 12 in. (30.5 cm) CCDC Pointed	
22043003	1/4 in. (6.4 mm) x 12 in. (30.5 cm) CCDC Pointed	
22053003	5/16 in. (7.9 mm) x 12 in. (30.5 cm) CCDC Pointed	
22063003	3/8 in. (9.5 mm) x 12 in. (30.5 cm) CCDC Pointed	
22082003	1/2 in. (12.7 mm) x 14 in. (35.6 cm) CCDC Pointed	

Note: Standard 50 pieces per carton unless noted. \* 100 pieces per carton.

Pointed Plain DC Electrodes		
Part No.	Description	Application
21983003	5/32 in. (4.0 mm) x 12 in. (30.5 cm) DC Pointed	General purpose electrodes without the copper plating to avoid any chance of copper contamination in the base material. Same high quality blend of carbon and graphite used in other electrodes.
21033003	3/16 in. (4.8 mm) x 12 in. (30.5 cm) DC Pointed	
21043003	1/4 in. (6.4 mm) x 12 in. (30.5 cm) DC Pointed	
21053003	5/16 in. (7.9 mm) x 12 in. (30.5 cm) DC Pointed	
21063003	3/8 in. (9.5 mm) x 12 in. (30.5 cm) DC Pointed	

Note: Electrodes will glow incandescent due to not having the copper plating and a penciling affect will take place along the outside diameter of the electrode. Standard 50 pieces per carton unless noted.

Pointed Copperclad AC Electrodes		
Part No.	Description	Application
20033003	3/16 in. (4.8 mm) x 12 in. (30.5 cm) CCAC Pointed	Designed for use with A.C. power supplies. Rare earth material is added to the electrodes to stabilize the arc and enhance the operating characteristics. 12 in. (305 mm) long.
20043003	1/4 in. (6.4 mm) x 12 in. (30.5 cm) CCAC Pointed	
20063003	3/8 in. (9.5 mm) x 12 in. (30.5 cm) CCAC Pointed	

Flat Copperclad DC Electrodes		
Part No.	Description	Application
35099003	3/8 in. (9.5 mm) x 3/16 in. (4.8 mm) x 12 in. (30.5 cm) Flat	Specially designed for close tolerance metal removal and scarfing applications. Excellent for general gouging applications, removing weld crowns, repairing or making dies, removing temporary welded dogs, and scarfing billets.
35033003	5/8 in. (15.9 mm) x 3/16 in. (4.8 mm) x 12 in. (30.5 cm) CCDC Flat	

Note: Standard 50 pieces per carton unless noted.

Half Round Copperclad DC Electrodes		
Part No.	Description	Application
25103003	5/8 in. (15.9) x 5/16 in. (7.9 mm) x 12 in. (30.5 cm) CCDC Half-Round	Versatility of having both a round and flat electrode for the various gouging applications. Excellent for removing weld crowns, repairing or making dies, removing temporary welded dogs, and scarfing billets.

Note: Standard 50 pieces per carton unless noted.

Jointed Jetrods® Copperclad DC Electrodes		
Part No.	Description	Application
24052003	5/16 in. (7.9 mm) x 14 in. (35.6 cm) CCDC Jointed	Provides continuous electrode feed and increased savings, especially in production operations. Suited for both hand held foundry applications and or automated gouging systems.
24062003	3/8 in. (9.5 mm) x 14 in. (35.6 cm) CCDC Jointed	
24064003	3/8 in. (9.5 mm) x 17 in. (43.2 cm) CCDC Jointed	
24082003	1/2 in. (12.7 mm) x 14 in. (35.6 cm) CCDC Jointed	
24084003	1/2 in. (12.7 mm) x 17 in. (43.2 cm) CCDC Jointed	
24104003	5/8 in. (15.9 mm) x 17 in. (43.2 cm) CCDC Jointed	
24124003	3/4 in. (19.05 mm) x 17 in. (43.2 cm) CCDC Jointed	

Note: Standard 100 pieces per carton unless noted.

## CutSkill Electrodes

Pointed Copperclad DC Electrodes		
Part No.	Description	Application
22033003C	3/16 in. (4.8 mm) x 12 in. (30.5 cm) CCDC Pointed	A standard, all purpose gouging electrode. Its controlled copper coating improves electrical conductivity (for more efficient, cooler operation) and helps maintain electrode diameter at the point of the arc.
22043003C	1/4 in. (6.4 mm) x 12 in. (30.5 cm) CCDC Pointed	
22053003C	5/16 in. (7.9 mm) x 12 in. (30.5 cm) CCDC Pointed	
22063003C	3/8 in. (9.5 mm) x 12 in. (30.5 cm) CCDC Pointed	

Note: Standard 50 pieces per carton unless noted. \* 100 pieces per carton.

Hollow Pointed Copperclad DC Electrodes		
Part No.	Description	Application
22033003HC	3/16 in. (4.8 mm) x 12 in. (30.5 cm) CCDC Pointed	General purpose electrodes having the same high quality blend of carbon and graphite used in other electrodes, but with a hole down the center of the electrode.
22043003HC	1/4 in. (6.4 mm) x 12 in. (30.5 cm) CCDC Pointed	
22053003HC	5/16 in. (7.9 mm) x 12 in. (30.5 cm) CCDC Pointed	
22063003HC	3/8 in. (9.5 mm) x 12 in. (30.5 cm) CCDC Pointed	
22082003HC	1/2 in. (12.7 mm) x 14 in. (35.6 cm) CCDC Pointed	

Note: Standard 50 pieces per carton.

Jointed Copperclad DC Electrodes		
Part No.	Description	Application
24064003C	3/8 in. (9.5 mm) x 17 in. (43.2 cm) CCDC Jointed	Provides continuous electrode feed for greatly increased savings, especially in production operations.
24084003C	1/2 in. (12.7 mm) x 17 in. (43.2 cm) CCDC Jointed	
24104003C	5/8 in. (15.9 mm) x 17 in. (43.2 cm) CCDC Jointed	
24124003C	3/4 in. (19.05 mm) x 17 in. (43.2 cm) CCDC Jointed	
24164003C	1 in. (25.4 mm) x 17 in. (43.2 cm) CCDC Jointed*	

Note: Standard 100 pieces per carton unless noted \* - 25 pieces per carton.

## Welding Carbon Products

### Carbon Plates and Carbon Rods

Wide Range of Applications to Control the Flow of Weld Metal

- Repair broken corners
- Repair broken gears
- Dams or molds for weld deposit

Eliminates the Need for Many Jigs and Fixtures

- Substantial time and labor savings

Ordering Information	
<b>Carbon Plate</b>	
48043012	1/4 in. (6.4 mm) x 12 in. (30.5 cm) x 12 in. (30.5 cm)
48063012	3/8 in. (9.5 mm) x 12 in. (30.5 cm) x 12 in. (30.5 cm)
48083012	1/2 in. (12.7 mm) x 12 in. (30.5 cm) x 12 in. (30.5 cm)
48123012	3/4 in. (19.05 mm) x 12 in. (30.5 cm) x 12 in. (30.5 cm)
48163012	1 in. (25.4 mm) x 12 in. (30.5 cm) x 12 in. (30.5 cm)
<b>Carbon rod</b>	
47123000	3/4 in. (19.05 mm) x 12 in. (30.5 cm)
47143000	7/8 in. (22.23 mm) x 12 in. (30.5 cm)
47164000	1 in. (25.4 mm) x 17 in. (43.2 cm)
47183000	1-1/8 in. (28.6 mm) x 12 in. (30.5 cm)
47203000	1-1/4 in. (31.8 mm) x 12 in. (30.5 cm)
47243000	1-1/2 in. (38.1 mm) x 12 in. (30.5 cm)
47323000	2 in. (50.8 mm) x 12 in. (30.5 cm)



## Arcair-Matic® N7500

### Automated Gouging System

The Arcair-Matic N7500 gouging system is highly productive for any metal fabrication operation where gouging and welding represents a large portion of the work schedule. This applies to almost all metals, including stainless steel, carbon, manganese, and chrome-moly steels.



### Digital LCD Remote Pendant

- Ease of use – start/stop function, travel delay, electrode diameter
- Rough machining feature to stall the feed of the electrode to compensate for pitted area or out-of-round steel rolls, thereby maintaining the concentricity of the shaft/roll
- US Patent No. US 9101998 B2
- “Travel delay” function assures excellent groove geometry at the very beginning of the groove, thereby eliminating the need for a starting pad
- Shock-absorbent bumper
- Remote Pendant incorporates an emergency stop switch (E-Stop) when pressed in, will take precedence over any other “stop” signal and will drop out the engaged contactor in the power supply stopping the flow of current to the carbon electrode



### Torch Head

- Small and lightweight while accepting the wide range of Arcair jointed Jetrod Copperclad DC carbons, 5/16 in. (7.9 mm) through 3/4 in. (19.05 mm)
- Can be oriented 360 degrees in any direction giving flexibility to fit the application



### Digital Circuitry Control Box

- Redesigned digital circuitry control box
- A synergic mode ensures conformity to pre-determined, pre-selected groove depth and width specifications
- Can be used with CC/CV power supplies and the system utilizes the contactor in the welding power supply unit thereby eliminating the need for an external contactor used on prior models



### Complete N7500 Gouging System

#### Ordering Information

65991015

Includes remote pendant, control box, torch head, air regulator and electrode tube holder

### System Cable Assembly Options\*

#### Ordering Information

##### 110V AC Power Supply Cable

96130304	10 ft (3 m)
----------	-------------

##### 220V AC Power Supply Cable

96130305	10 ft (3 m)
----------	-------------

##### Pendant Cable Assembly

96170069	14 in. (0.36 m)
----------	-----------------

96170070	15 ft (5 m)
----------	-------------

96170071	25 ft (8 m)
----------	-------------

96170072	50 ft (15 m)
----------	--------------

##### Motor Cable Assembly

96130335	3 ft (0.9 m)
----------	--------------

96130336	15 ft (5 m)
----------	-------------

96130337	25 ft (8 m)
----------	-------------

96130338	50 ft (15 m)
----------	--------------

##### Power Supply Communication Cable Assembly

96130339	15 ft (5 m)
----------	-------------

96130340	25 ft (8 m)
----------	-------------

96130341	50 ft (15 m)
----------	--------------

##### DC Power Cables

96130254	4 ft (1.2 m)
----------	--------------

96130256	15 ft (5 m)
----------	-------------

96130300	25 ft (8 m)
----------	-------------

NOTE: Minimum 2 Power Cables Required

##### Air Hose Assembly

94396051	4 ft (1.2 m)
----------	--------------

94396049	15 ft (5 m)
----------	-------------

94396048	25 ft (8 m)
----------	-------------

\*Must be ordered separately

## All Position Travel Systems

Arcair, the industry leader in air carbon-arc products partnered with leading travel system manufacturers to create the best all-around metal removal system providing superior performance, flexibility, versatility, and safety for your metal removal applications.

BUG-O® and GULLCO® tractors are ideal for out of position metal removal applications. Both systems incorporate an aluminum track that guides the tractor down the weld seam with the ability to keep the Arcair-Matic N7500 torch head on track with a mechanical rack device.

### Bug-O Travel System Packages

All travel systems include a complete N7500 Automated Gouging System

- Remote pendant
- Control box
- Torch head
- Arcair electrode tube holder
- Arcair air regulator



MANUAL  
GOUGING

Ordering Information	
Rigid - 110 VAC	71023140
Rigid - 220 VAC	71023141
Flex - 110 VAC	71023142
Flex - 220 VAC	71023143

\* System Part No. includes the BUG-O items as noted along with the Arcair-Matic N7500 System.

Bug-O Travel System Specifications							
Carriage	Master Drive Unit	Arc Gouging Control Module	Arcair Mounting Group	Cable Mounting Assembly	Rail	On/Off Magnet	
MPD-1065 (12 in. Releaseable Carriage)	MPD-1000 (110 VAC)	AGS-1002	AGS-4172	BUG-2975	ARR-1080 (Heavy-Duty Aluminum Rail)	ARM-2010 (5 Magnets)	
MPD-1065 (12 in. Releaseable Carriage)	MPD-1002 (220 VAC)	AGS-1002	AGS-4172	BUG-2975	ARR-1080 (Heavy-Duty Aluminum Rail)	ARM-2010 (5 Magnets)	
FMD-1105 (HI-Flex Carriage w/ Handle & Clamp)	MPD-1000 (110 VAC)	AGS-1002	AGS-4172	--	FMD-2170 (HI-Flex Rail)	FMD-2010 (8 Magnets)	
FMD-1105 (HI-Flex Carriage w/ Handle & Clamp)	MPD-1002 (220 VAC)	AGS-1002	AGS-4172	--	FMD-2170 (HI-Flex Rail)	FMD-2010 (8 Magnets)	

### GULLCO Travel System Packages

All travel systems include a complete N7500 Automated Gouging System

- Remote pendant
- Control box
- Torch head
- Arcair electrode tube holder
- Arcair air regulator



Ordering Information	
Rigid - 110 VAC	71023144
Rigid - 220 VAC	71023145

\* System Part No. includes the GULLCO items as noted along with the Arcair-Matic N7500 System.

Gullco Travel System Specifications					
Carriage	Rack Box	Rack Bar	Welding Gun Attachment	Track	Track Magnet Devices
GK-200-RHB-N (GULLCO "KAT" Variable Speed Travel Carriage - 110 VAC)	GK-171-650 (GULLCO Heavy Duty Rack Box)	GK-171-047-2 (GULLCO 18 in. Long Heavy Duty Square Rack Bar)	GK-165-047-2 (GULLCO 4-Motion Semi-Automatic Welding Gun Attachment)	GK-165-052-1 (GULLCO 96 in. Aluminum Alloy Standard Track)	GK-165-215 (6 GULLCO Track Magnet Devices)
GK-200-RHC-N (GULLCO "KAT" Variable Speed Travel Carriage - 220 VAC)	GK-171-650 (GULLCO Heavy Duty Rack Box)	GK-171-047-2 (GULLCO 18 in. Long Heavy Duty Square Rack Bar)	GK-165-047-2 (GULLCO 4-Motion Semi-Automatic Welding Gun Attachment)	GK-165-052-1 (GULLCO 96 in. Aluminum Alloy Standard Track)	GK-165-215 (6 GULLCO Track Magnet Devices)

BUG-O is a registered trademark of the Weld Tooling Corporation. Gullco is a registered trademark of Gullco Enterprises Limited. The aforementioned registered trademarks are in no way affiliated with Arcair. Arcair is a registered trademark of ESAB.

## Titan Travel System Packages

### Straight Line Flat Position Carriage

For metal removal applications in the flat position only, Arcair offers a machine carriage system that can carry the complete Arcair-Matic N7500 system and can be easily lifted on and off the work surface with an overhead crane. The track section consists of a steel "T" bar, machined on each end to permit joining additional sections easily. The same machine carriage can come with "outrigger" wheels to guide the carriage down the work surface, ideal for bridge girder back-gouging applications.

### All travel systems include a complete N7500 Automated Gouging System

- Remote pendant (72008020)
- Control box (72008021)
- Torch head (05-124-001)
- Arcair electrode tube holder (94893082)
- Arcair air regulator (71000073)

*With the exception of the power communication cable assembly, all other system cable assemblies, 110V AC power cable, pendant cable, motor cable, dc power cable, and air hose assemblies are included.*



Ordering Information		Arcair Titan Travel System Specifications							
		Horizontal Rack Bar	Vertical Rack Bar	Outrigger Wheel Pkg	Track	Pointer Assembly	Magnet Supports	Cable-Hose Clamp	Lift Bracket
Titan Machine Carriage System Package with Track - 110 VAC	71022704								
Titan Machine Carriage System Package w/ Outrigger Wheel Package - 110 VAC	71022705	71099073	71099074	-	71022501 (Arcair 10 ft "T" Steel Track Section)	71022502	71022504 (3 Magnets)	71022506	94111168
		71099073	71099074	80345	-	-	-	71022506	94111168

*\* System Part No. includes the items as noted along with the Arcair-Matic N7500 System.*

### Titan with Outrigger Wheel Package



EXOTHERMIC CUTTING

## Arcair Titan Machine Carriage

Ideal for any automated applications in metal fabrication operations where gouging, welding and cutting represents a large portion of your work schedule. And that applies to almost all metals, including stainless, carbon, manganese, and chrome-moly steels.

### Flat Plate Work

Arcair Titan Machine Carriage is designed for low maintenance and high performance in straight line operation such as automated air-carbon arc gouging, cutting or welding operations. Available in speed ranges from 6 – 80 i.p.m. (15.2 – 203.2 cm/min).



Specifications	
<b>Dimensions L x W x H</b>	<b>Weight</b>
24 x 21 x 5-7/8 in. (61 x 53.3 x 14.9 cm)	61 lb (27.7 kg)
<b>Weight Capacity</b>	<b>Mounting Area</b>
Flat Position: 300 lb (136.1 kg)	245 in <sup>2</sup> (1,639 cm <sup>2</sup> )

Ordering Information	
71022501	Titan Machine Carriage - 6-80 ipm (15.2 - 203.2 cm/min (110 VAC, 60 Hz)

Options & Accessories	
71022502	Track Section 10 ft (3 m) Long
71022504	Magnet and Support Bar Assembly [3 ea required per 10 ft (3 m)]

## Arcair Horizontal & Vertical Rack Bar Positioners

### Ruggedness, Rigidity

- Made from heavy gauge aluminum and brass to operate under severe operating conditions

### Accuracy & Ease of Operation

- Precision machined parts ensures accurate torch/tool positioning
- Positioners do not need to be disassembled to reposition or remove

### Horizontal Rack Bar Positioner



Specifications	
<b>Dimensions L x W x H</b>	<b>Weight</b>
26 x 4 x 9-7/8 in. (66 x 10 x 24.5 cm)	61 lb (27.7 kg)

Ordering Information	
71099073	Horizontal Rack Bar Assembly

### Vertical Rack Bar Positioner



Specifications	
<b>Dimensions L x W x H</b>	<b>Weight</b>
6 x 4-1/2 x 13-7/8 in. (35.2 x 11.4 x 15.2 cm)	3.1 lb (1.4 kg)

Ordering Information	
71099074	Vertical Rack Bar Assembly

EXOTHERMIC CUTTING

## SLICE® Exothermic Cutting System

### Versatile - Unlike Any Other Cutting Technology

- Cuts right through hard-to-cut materials
  - Mild, stainless steel and alloy steels
  - Cast iron
  - Aluminum, magnesium and other non ferrous metals
  - Slag and refractory materials
  - Pierces through concrete or brick

### Fast Cutting Speeds

- No-preheat required
- Cut sooner and finish every job faster

### Comfortable and Easy to Use

- Pistol grip style handle
- Lightweight shield to protect the operator from heat and sparks
- Lever operated oxygen control

### Carry All Convenience

- Several portable SLICE packs to choose from
  - Utility Pack
  - Battery Pack
  - Industrial Pack
  - Complete Pack



 [arcairslice.com](http://arcairslice.com)

Specifications				
Input Voltage	Length of Power Cable & Oxygen Hose	Power Cable AWG Size	Certification Mark (Standards)	Weight
12 V Battery (not included)	10 ft (3 m)	#10 #6 #1	CE	#10 - 3.8 lb (1.7 kg) #6 - 4.4 lb (2.0 kg) #1 - 6.3 lb (2.9 kg)

Ordering Information	
03003012	SLICE Cutting Torch w/ #10 Power Cable (When Igniting w/ 12V Battery & Cutting w/o Power)
03003011	SLICE Cutting Torch w/ #6 (When Igniting 12V Battery & Cutting w/o Power)
03003010	SLICE Cutting Torch w/ #1 (Up to 200 A w/ Power)



EXOTHERMIC CUTTING



## Tips for Using SLICE® Exothermic Cutting Equipment

### TIPS FOR CUTTING

Cutting procedures will vary from job to job. Study the cutting rates chart for specific cutting speeds.

Normal cutting is done by using a drag technique. Once the rod is in contact with the piece to be cut, drag the rod in the direction of the cut. If the operator cannot see the kerf, the speed of cut is too fast. If the rod is being used too rapidly the progress of the cut is too slow and the rod is being used without cutting. REMEMBER, the cutting rods consume as long as the oxygen is flowing. Maintain the proper travel speed at all times.

NOTE: Use a sawing motion when material to be cut is thicker than 1-1/2 to 2 inches to ensure a complete melt through.

Use a smooth motion to complete the cut. Be careful not to hit nearby material with the rod when cutting in “close quarters.” After completing the cut, release the oxygen control lever in the handle. THE CUTTING ROD WILL CONTINUE TO BURN AS LONG AS OXYGEN IS SUPPLIED. Hold the torch safely away from you until the rod cools.

### TIPS FOR PIERCING SURFACES

The SLICE Torch can be used to pierce solids. Special procedures must be used when piercing. When piercing, use a collet extension (and shield). This extension adds life to the torch and hand shield, and greatly improves operator safety and comfort. Always hold the torch at arm’s length and wear plenty of protective clothing, eye and ear protection. Cutting rods can get stuck inside the pierced hole. If possible, remove the cutting rod from the hole before releasing the oxygen lever.

With any thermal cutting equipment blowback is most likely to occur when the user is piercing holes. Cutting rods may burn unevenly. Slowly swirl the cutting rod as it enters a pierced hole. Cutting rods may burn out on the sides. Correct the problem by removing the cutting rod from the pierce point, shut the oxygen off, and replace the cutting rod.

To pierce follow these steps:

- Strike cutting rod on striker.
- Hold torch at arm’s length
- Keep the cutting rod at a 90° angle (perpendicular) to the pierce point
- Slowly push cutting rod in at pierce point until you are at proper depth or until you have achieved burn through

The pierce procedure is also used to cut concrete. By piercing a series of holes where a user wants to cut concrete, the concrete becomes easier to fracture. This helps reduce the time it would take to actually cut the concrete.

### OXYGEN USAGE

This cutting process uses standard industrial grade oxygen to support the exothermic reaction and to remove the molten metal. All SLICE equipment uses standard oxygen fittings.

The most commonly recommended operating pressure is 80 psi. Applications such as cutting material sections 3 in. (7.6 cm) and thicker might require higher operating pressures. Pressures as low as 40 psi have been used to perform operations such as washing off rivet heads and scarfing out small cracks for repair.

The oxygen consumption rate for the SLICE cutting rods at 80 psi is 7 to 7.5 cfm for the 1/4 in. (6.35 mm) diameter cutting rods and 11 to 12 cfm for the 3/8 in. (15.87 mm) diameter cutting rods. This rate will vary if a different operating pressure is used.

### ROD BURNTIME

Listed are the approximate burntimes for the various SLICE rod diameters and lengths:

- 1/4 in. x 22 in. (6.4 X 559 mm) . . 40 - 45 seconds
- 1/4 in. x 44 in. (6.4 X 1118 mm) 80 - 90 seconds
- 3/8 in. x 18 in. (9.5 X 457 mm) . . 30 - 35 seconds
- 3/8 in. x 36 in. (9.5 X 914 mm) . . 60 - 70 seconds

### APPLICATION DATA

The best techniques for the SLICE equipment will change from job to job. The enclosed charts present the results of extensive testing of the SLICE Torch. Four things contribute to good cutting:

- 1) Electrical current
- 2) Type of material being cut
- 3) Environmental conditions
- 4) Experience of the operator(s)

These data result from studies of the first two (2) items in this list. Since data were collected in a laboratory, actual results obtained will vary because of changes in the environment. Too, these tests were conducted by highly experienced users. The way in which you use the SLICE Torch will also cause your results to vary.

In any application, some adjustments in operating conditions are necessary. The charts are presented only as a guideline. Results will vary. You can approximate these results by using the data presented as a starting point, then adjusting for your job.

Here is a sample of some cutting rates that can be obtained using the SLICE equipment. Cutting rates in this chart were obtained using 80 psi oxygen pressure, battery ignition (no power cutting) and 1/4 in. x 22 in. (356 x 559 mm) cutting rods. These cutting rates will vary when using different rods, when cutting with power or using a different oxygen pressure. This chart does not represent all materials SLICE will cut nor all thicknesses used in fabrication. When cutting composite materials or metals not listed, locate the listed type that most closely matches the metal to be cut. This information is only meant as a reference to the efficiency and versatility that a user can realize using the SLICE equipment.

Cutting Rates						
Material Being Cut	Thickness		Cut/in Rod		Cut Speed	
	in.	cm	in.	cm	in/min	cm/min
Carbon Steel	1/8	.318	2.25	5.7	72	183
	1/4	.635	1.50	3.8	52	132
	3/8	.953	1.38	3.5	42	106
	1/2	1.27	1.25	3.2	35	89
	3/4	1.91	0.75	1.9	22	56
Stainless Steel	1/8	.318	2.00	5.1	65	165
	1/4	.635	1.13	2.9	36	91
Aluminum	1/4	.635	1.75	4.4	58	147
	3/8	.953	1.25	3.2	38	97
	3/4	1.91	0.75	1.9	23	58

*This data is the result of averaging lab tests. The actual results will vary.*

## SLICE® Battery/Utility Pack

Go anywhere and cut, burn, or pierce virtually any metallic, non-metallic or composite material with this exothermic cutting pack. Comes with all the necessary equipment and cutting rods required to do cutting when combined with standard industrial grade oxygen to support the exothermic reaction and to remove the molten metal.



- New heavy-duty storage case to hold/store the equipment when not in use
- Improved torch handle and rubber shield to improve the operator's grip and provide protection from molten spray when piercing
- Improved striker assembly that incorporates a slide mechanism that allows the operator to only expose a small portion of the ignition bar (copper), which increases the life of the striker copper bar

Battery Pack Only:

- Improved battery ignition source with improved features over prior model
  - Faster recharging of a “dead” battery
  - Better visual “gas gauge” indicating battery condition
  - Over-charging safe guard

Specifications				
Input Voltage	Length of Power Cable & Oxygen Hose	Power Cable AWG Size	Certification Mark (Standards)	Weight
120 V AC 60 Hz 220 V AC 50 Hz (Battery Pack)	10 ft (3 m)	#10	CE	Battery Pack 28 lb (12.7 kg) Utility Pack 21 lb (9.5 kg)
Output Voltage	Type of Battery	Recharge Time	Exothermic Cutting Rods	Dimensions L x W x H
12 V DC	Seal lead acid	6 h (fully drained)	1/4 in. x 22 in. Uncoated – 25 pieces	22.25 x 20 x 5.5 in. (565 x 508 x 140 mm)

Ordering Information	
63991041	SLICE Battery Pack – 120 V AC 60 Hz
63991044	SLICE Battery Pack – 220 V AC 50 Hz
63991047	SLICE Utility Pack

## SLICE® Battery Ignition Source

The improved battery ignition source features faster recharging, better visual gas gauge and over-charging safe guard.

Accepts the SLICE cutting torch power connection that has the twist-lock power pin and the SLICE Striker Assembly that completes the circuit when the SLICE rod held in the cutting torch comes in contact with the Striker copper bar. With oxygen flowing through the torch and cutting rod the exothermic reaction begins and cutting can start. Simply release the oxygen lever on the torch to stop the burn.



- All connections to the battery ignition source are labelled for ease of use
- Illuminated lights “GAS GAUGE” signifies the level of the battery current output to ignite the cutting rod
- Experienced operators can expect to achieve 115+ ignitions from a fully charged battery
- Charging time to bring a fully drained battery up to a fully charged status is 6 hours

Specifications				
Input Voltage	Internal Battery Display	Charging Mode	Certification Mark (Standards)	Weight
22-30 V DC	LED	Constant Voltage	CE	7.1 lb (3.22 kg) Battery Case & Power Adapter
Output Voltage	Type of Battery	Adapter Input	Adapter Output	Dimensions L x W x H
12 V DC	Seal lead acid	100 – 240 VAC 50 – 60 Hz 1.4 A Max	24 V DC, 2.7 A	6.4 x 4.6 x 7.4 in. (163 x 117 x 188 mm)

Ordering Information	
96076040	SLICE Battery Ignition Source
96076041	Power Adapter w/ NAM Power Lead

## SLICE® Industrial Pack

A self-contained cutting system lends itself well for maintenance/repair inside of manufacturing facilities.

- Improved torch handle and rubber shield to improve the operators grip and provide protection from molten spray when piercing
- Improved striker assembly that incorporates a slide mechanism that allows the operator to only expose a small portion of the ignition bar (copper) which increases the life of the striker copper bar
- Improved battery box with improved features over prior model
  - Faster recharging of a “dead” battery
  - Better visual “gas gauge” indicating battery condition
  - Over-charging safe guard
- Storage shelf on the cart to place a 12V battery for the power to ignite the SLICE rod and begin exothermic cutting action (12V battery not included with system)
- System includes a battery charger mounted on the cart to recharge the 12V battery as needed



## SLICE® Complete Pack

A self-contained cutting system lends itself well to the emergency/forced entry type cutting situations where seconds count.

- Improved torch handle and rubber shield to improve the operators grip and provide protection from molten spray when piercing
- Improved striker assembly that incorporates a slide mechanism that allows the operator to only expose a small portion of the ignition bar (copper), which increases the life of the striker copper bar
- Improved battery box with improved features over prior model
  - Faster recharging of a “dead” battery
  - Better visual “gas gauge” indicating battery condition
  - Over-charging safe guard



Specifications				
Input Voltage	Length of Power Cable & Oxygen Hose	Power Cable AWG Size	Certification Mark (Standards)	Weight
120 V AC 60 Hz	10 ft (3 m)	#10	CE	81.2 lbs (36.8 kg)
Output Voltage	Exothermic Cutting Rods			Dimensions L x W x H
12 V DC	1/4 in. x 22 in. Uncoated – 25 pieces			20-5/8 x 48-3/8 x 20 in. (524 x 1229 x 508 mm)

Ordering Information	
63991045	SLICE Industrial Pack – 120 V AC 60 Hz

Specifications				
Input Voltage	Length of Power Cable & Oxygen Hose	Power Cable AWG Size	Certification Mark (Standards)	Weight
120 V AC 60 Hz 220 V AC 50 Hz	10 ft (3 m)	#10	CE	With Cylinder 70 lb (31.75 kg) Without Cylinder 39.05 lb (17.71 kg)
Output Voltage	Recharge Time	Exothermic Cutting Rods		Dimensions L x W x H
12 V DC	6 h (fully drained)	1/4 in. x 22 in. Uncoated – 25 pieces		With Cylinder: 15 x 27 x 8 in. (400 x 689 x 206 mm) Without Cylinder: 15 x 25 x 8 in. (400 x 638 x 206 mm)

Ordering Information	
63991040	SLICE Complete Pack – 120 V AC 60 Hz
63991042	SLICE Complete Pack – 220 V AC 50 Hz

## SLICE® Striker Assembly



The SLICE Striker comes standard with a #10 AWG Power Cable with a twist-lock brass pin that can connect to the SLICE battery ignition source. The same twist-lock pin can be inserted into the mating receptacle on a plier type clamp found in the SLICE Utility Pack (please see separate fact sheet for details).

- Improved striker assembly that incorporates a slide mechanism that allows the operator to only expose a small portion of the ignition bar (copper), which increases the life of the striker copper bar
- Robust handle insulator material that can handle impact with the ground and high temperature rating

Specifications		
<b>Length of Power Cable &amp; Oxygen Hose</b>	<b>Power Cable AWG Size</b>	<b>Certification Mark (Standards)</b>
10 ft (3 m)	#10	CE
<b>Weight</b>	<b>Dimensions L x W x H</b>	
1.2 lb (.54 kg)	9.5 x 1.5 x 1.75 in. (241.3 x 38 x 44.5 mm)	

Ordering Information	
72012010	SLICE Striker Assembly

## SLICE® Cutting rods

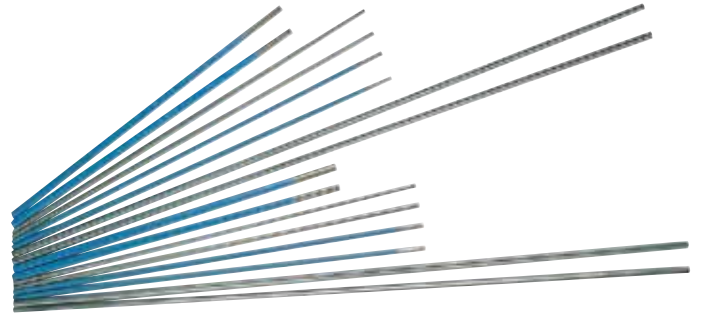

Unlike any other cutting process used today, SLICE systems can cut, burn or pierce virtually any metallic, non-metallic or composite material. Specially designed flux-coated cutting rod, patented single piece construction maintains the balance necessary to sustain the exothermic reaction.

- Specially designed cutting rod
- One piece patented construction maintains the balance necessary to sustain the exothermic reaction
- Cutting rod sustains the burn without constant electrical power once ignited

Ordering Information	
42049003	SLICE Exothermic Cutting Rods, Flux Coated, 1/4 x 22 – 100 Pcs
42049002	SLICE Exothermic Cutting Rods, Flux Coated, 1/4 x 22 – 25 Pcs
43049009	SLICE Exothermic Cutting Rods, Uncoated, 3/8 x 36 – 25 Pcs
43049007	SLICE Exothermic Cutting Rods, Uncoated, 3/8 x 18 – 50 Pcs
43049002	SLICE Exothermic Cutting Rods, Uncoated, 1/4 x 22 – 25 Pcs
43049005	SLICE Exothermic Cutting Rods, Uncoated, 1/4 x 44 – 25 Pcs
42049005	SLICE Exothermic Cutting Rods, Flux Coated, 3/8 x 18 – 50 Pcs
43049003	SLICE Exothermic Cutting Rods, Uncoated, 1/4 x 22 – 100 Pcs
94463032	3/8 in. Collet Conversion Kit

# MAJOR UPGRADE: ARCAIR® SLICE® EXOTHERMIC CUTTING SYSTEM.

The fastest way to cut, burn or pierce virtually any metallic, nonmetallic or composite material. SLICE cuts anything put in front of its 8,000°F to 10,000°F flame, including steel, aluminum, cast iron, brass, nickel, concrete or firebrick.

The portability and cut-anything capabilities of SLICE systems make them preferred tools for forcible entry (fire and rescue), heavy equipment repair and maintenance, steel erection, bridge construction, and scrap and demolition work.

## SLICE ENHANCEMENTS.

- More-ergonomic torch grip and oxygen flow lever.
- Stronger connection between grip and rubber shield.
- New striker assembly extends striker life by exposing ignition bar in small increments.
- Improved 12V ignition source for faster recharging of a dead battery, overcharging safeguard and a better visual indication of battery condition.

## FOUR SLICE PACK OPTIONS.

### 1. SLICE Utility Pack.

Includes everything required for cutting except the 12V battery and oxygen cylinder.

### 2. SLICE Battery Pack.

Includes improved 12V ignition source. No cylinder.

### 3. SLICE Complete Pack.

Includes improved 12V ignition source and 55-cu.-ft. oxygen cylinder and oxygen regulator. Metal carrying case makes it well-suited for forcible-entry situations when seconds count.

### 4. SLICE Industrial Pack.

Cart accommodates a large oxygen cylinder to extend cutting time, and a 12V AC battery charger.



# // MANUAL PLASMA







# WE'VE CREATED A CUTTING BEAST.



**THE FIERCEST PLASMA CUTTER IN ITS CLASS.  
KILLER POWER-TO-WEIGHT RATIO // INSANE CUTTING ARC  
VICIOUS TORCH // MONSTROUS DISPLAY**

Find out how you can unleash the Thermal Dynamics® **Cutmaster® 60i** at [esab.com/beast](https://esab.com/beast).



## CONTENTS

Plasma Cutting Process.....	90
-----------------------------	----

### CUTTING MACHINES

Cutmaster® 42 .....	92
Cutmaster® 58 .....	92
Cutmaster® 60i .....	93
Cutmaster® 82 .....	94
Cutmaster® 102 .....	94
Cutmaster® 152 .....	95
PAK® 200i .....	95

### PLASMA TORCHES

1TORCH® SL60 .....	96
1TORCH® SL100 .....	96
1TORCH® Mechanized SL100, Automation SL100SV .....	96
Torch Connection Options - Remote Control.....	97
Plasma Torch Adapter Kits Selection .....	98
1TORCH® Consumables .....	99
1TORCH® Consumables Parts Application Guide .....	99

### PLASMA ACCESSORIES

Plasma Accessories .....	100
--------------------------	-----



Dr. James Browning, Founder



**1957**

Dr. James Browning & Merle Thorpe found Thermal Dynamics.

**1970**

First PAK® unit-power supply, PAK 40, cooling system, and console combined into one unit.

**1975**

PAK 44 incorporated plug-in relays, torch auto-pilot, and constant current.

**1980**

First single phase machine introduced, PAK 5.

**1982**

PAK-3, the first PAC system to use air as plasma gas; for cutting gauge thickness material.

**1990**

Plasma gouging introduced, PAK 15XC

**1997**

PakMaster® XL series and the Econopak® provide more portability.

**1998**

The Drag-Gun® introduced as the first cutting system with a built-in air compressor.

# AT THE FOREFRONT OF PLASMA CUTTING INNOVATION

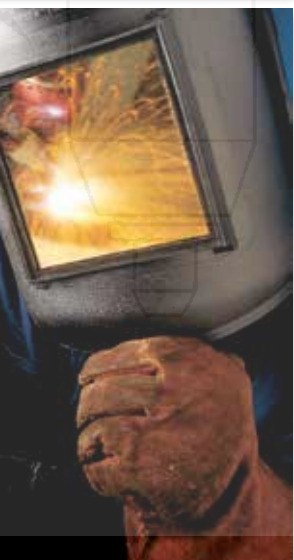

**1999**  
PakMaster® XL Plus Series  
introduced.

**2000**  
Cutmaster® 50 &  
Sure Lok® RPT  
replacement torches  
introduced.

**2002**  
Torch® and ATC® connection were  
introduced with SureLok®  
technology. First non-High  
Frequency system introduced with  
the Cutmaster® 38

**2004**  
Cutmaster 1Series®;  
51/81/101 launched.

**2008**  
Cutmaster TRUJE™ Series;  
39/52/82/102/152 launched.

**2011**  
Cutmaster 42 with SL40 torch  
utilizing V2S technology.

**2014**  
Thermal Dynamics  
becomes  
An ESAB Brand

**2017**  
ESAB launches the  
Thermal Dynamics  
Cutmaster 60i

## Plasma Cutting Process

### From the Market Leaders

Since Thermal Dynamics® developed the plasma arc process in 1953 and incorporated in 1957, we have introduced a number of innovations to ensure peak performance in plasma cutting and gouging.

Today, ESAB's product line includes the full range of Thermal Dynamics systems designed to meet your specific needs and applications.

### Process Description

Plasma arc cutting is a relatively simple operation and widely accepted for cutting ferrous and non-ferrous metals. The plasma arc's straight, narrow, column-like shape and high current density allow the operator to achieve cut consistency without maintaining a constant distance between the nozzle and the workpiece.

Plasma cutting involves using a torch, compressed gas, and a source of electric power to create a constricted arc that melts a localized area of metal and removes the molten material with a high-velocity jet of hot, ionized gas.

During plasma cutting, a compressed gas and an electric arc are simultaneously passed through a small orifice, which is typically 0.040 in. (1.0 mm) to 0.125 in. (3.18 mm) in diameter. An electric arc heats the gas to a plasma state at a temperature as high as 50,000°F (27,760°C). This super-heated plasma jet is directed to the area to be cut, and the jet melts a path through the metal. Because it is a melting process, plasma cutting can cut almost any commercially used metal.

Plasma gouging is a variation of the plasma cutting process. The torch nozzle configuration is designed to produce a lower velocity, broader arc. Rather than cutting completely through the metal, the torch is held at an angle so the arc gouges a U-shaped groove in the metal.

Plasma cutting can be accomplished manually or mechanically. In mechanical setups, a plasma torch is driven by an automatic machine that is typically regulated by a computer numerical control (CNC) to cut a predetermined shape. This section focuses on manual plasma cutting, in which the plasma torch is manipulated by hand to perform a variety of metal cutting tasks.

Manual systems are available in a variety of sizes. Generally rated in amperage output or cutting capacity, the units range from about 15 to 300A output, encompassing a cutting capacity ranging from 1/4 in. (6.35 mm) to approximately 4 in. (101.6 mm).

Manual units can also be divided into two general categories. Stationary or console systems generally are designed to remain fixed in one place, although most are equipped with wheels that make it possible to move them around a shop. Portable systems are designed to be carried around by one or two workers, allowing them to move the system where it is needed rather than taking materials to be cut to one location.

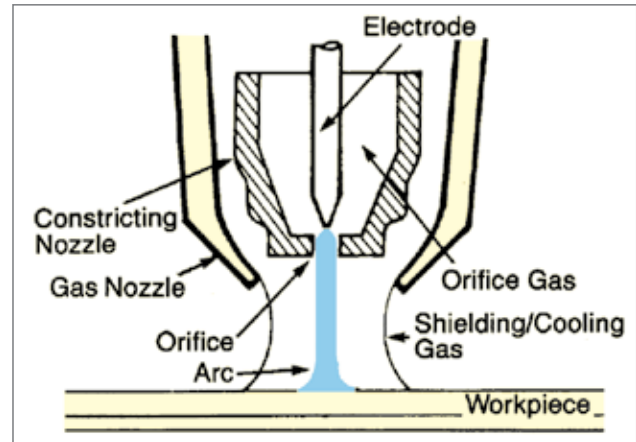

Plasma Arc Cutting

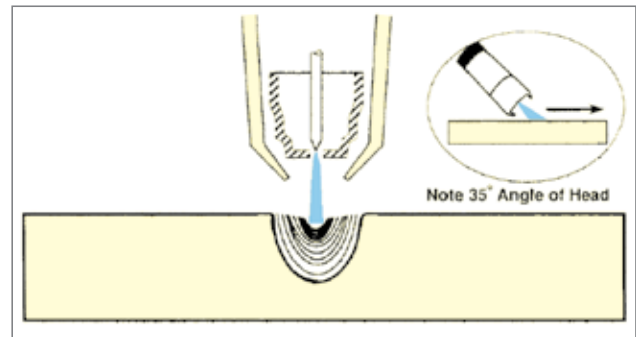

Plasma Arc Cutting

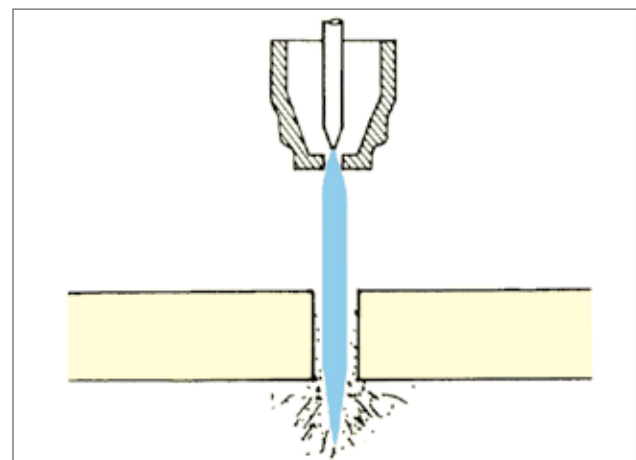

Plasma Arc Gouging

## Plasma Cutting Process

### The Cutting Torch

One of the most important considerations in choosing a system is the front-end design of the plasma cutting torch, because it controls the cut and most heavily influences the operating costs of the setup. If reaching tight places is important, a torch with a small or narrow front end is a good choice. A smaller front end may also be a better choice in applications that require a clear line of vision to follow a cut line, because a larger front end could obscure vision.

In addition to the up-front costs for nozzles, electrodes, and other front-end parts, you should consider the durability of the parts and the life in arc hours you can expect from the nozzle and electrode combination. These factors are better indicators of operating costs than are the prices of the parts alone.

Plasma cutting torch parts are generally made to very high tolerances. Make sure that any replacement parts you use are made to proper specifications. The wrong replacement parts can result in poor performance and damage to the torch head, which could require an expensive repair.

### Recommended Cutting Gases

**Compressed Air** is the most commonly used gas for lower current plasma cutting and works well for most metals from gauge thickness to 1 in. (25.4 mm). It leaves an oxidized cut surface. Compressed air can also be used for plasma gouging on carbon steel.

**Nitrogen (N<sub>2</sub>)** is often used for higher current plasma systems and for cutting materials up to 3 in. (76.2 mm) thick. It produces excellent quality cuts on most materials.

**Argon-Hydrogen Mixtures (H-35)** are generally used for cutting stainless steel and aluminum. They produce a clean, high quality cut face. Argon-Hydrogen is required for mechanized cutting of any material more than 3 in. (76.2 mm) thick. This mixture also provides an excellent gas for plasma gouging on all materials.

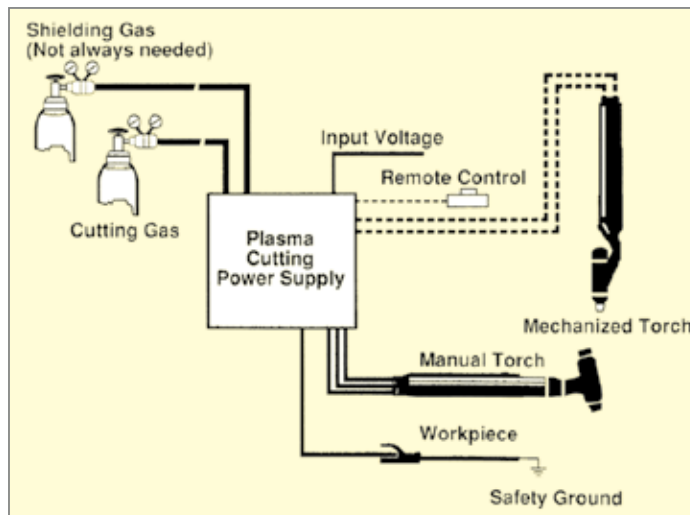

Finally, the best way to evaluate a manual plasma cutting system for your application is to ask for a demonstration. Many of the factors that determine which unit is right for you become obvious when you see the unit demonstrated in your own shop. Pay particular attention to cut speed, quality, ease of use, and portability, if that is an issue. If access is limited to an area to be cut, make sure that the cutter you evaluate can do the job.

### Important Product Safety

Sound common sense procedures must be followed for personal protection and operating efficiency when using manual plasma cutting equipment. Always comply with the manufacturer's recommendations for operating and maintaining the equipment, as set forth in the instructions provided with each unit. Also, be certain to use all applicable safety precautions, as described in [Precautions and Safe Practices for Arc Welding, Cutting and Gouging \(F-52-529\)](#), which is available by contacting ESAB at 1-800-ESAB.123 or visiting [esabna.com](http://esabna.com).

## Cutmaster® 42

The power of two machines built into one



- The Cutmaster® 42 is one of the most affordable, highest quality 120 V, 1/4 in. (6 mm) plasma systems on the market
- At 230 V, the Cutmaster 42 delivers 40 A, and recommended cut of 3/8 in. (9.5 mm)
- As part of the TRUE™ Series, you can rely on the Cutmaster 42 to cut all day at its recommended cutting capacity and to pack more punch when you need it
- The Cutmaster 42 with SL40 torch incorporates Vent2Shield™ (V2S) technology allowing the use of a considerably smaller compressor (less weight to carry, can be used with 120 V) compared to similar 40 A units

### Specifications

Input Voltage	Recommended Cut	Maximum Cut	Duty Cycle	Pierce Rating	Max Amperage Output	Torch Air Pressure	Torch Air Consumption
120/230 V, 1 ph, 50/60 Hz	120 V: 1/4 in. (6 mm) 230 V: 3/8 in. (9.5 mm)	120 V: 5/8 in. (15 mm) 230 V: 3/4 in. (20 mm)	40% @ 40 A @ 230 V	120 V: 1/4 in. (6 mm) 230 V: 3/8 in. (9.5 mm)	27 A @ 120 V 40 A @ 230 V	75 psi (5.2 bar)	SL40 3.2 cfm (91 l/m) SL60 6.7 cfm (190 l/m)
Amperage Draw	Gouging Profiles	Output Range	Depth	Width	Dimensions L x W x H	Weight	
29 A @ 120 V 15 A @ 230 V	Tip A (SL60 torch only)	40 A (Max)	Shallow	Narrow	18.5 x 7 x 9 in. (470 x 177 x 228 mm)	26 lbs. (11.8 kg)	

### Ordering Information

Cutmaster 42, SL40 75° hand torch, 15 ft. (4.5 m), 120/230 V, 1ph CSA	1-4200	Cutmaster 42, SL40 75° hand torch, 15 ft. (4.5 m), 120/230 V, 1ph CSA	1-4200-7
Cutmaster 42, SL60 75° hand torch, 20 ft. (6.1 m), 120/230 V, 1ph CSA	1-4200-SL60	Cutmaster 42, SL40 ATC 75° hand torch, 15 ft. (4.5 m), 120/230 V, 1ph CSA	7-0040

Cutmaster 42 systems include: Power supply, torch, spare parts kit, input power cable, work cable and clamp, shade 5 safety glasses, power plug adapters, welding gloves, heavy-duty carry case and an instructional DVD.

## Cutmaster® 58

Medium-duty, portable plasma cutting system



- The Cutmaster® 58 is the most powerful 5/8 in. (16 mm) machine on the market today
- Cuts through mild and stainless steel, or aluminum up to 1 in. (25 mm) thick
- 1/2 in. (13 mm) pierce rating
- Combines power with the well-known performance and features of the industry-leading 1Torch®
- 6.2 kW rated output, 50% duty cycle at 60A, available in either 208-480V or 600V system - either system is capable of being wired single or three phase
- Simple switch at the back of the system allows for low or high voltage applications and automatic voltage detection within each range
- Built for portability and durability with the integral multi-handle design

### Specifications

Input Voltage	Recommended Cut	Pierce Rating	Max Amperage Output	Output Power	Torch
208-230/460 V, 1/3 ph, 50/60 Hz 400 V, 3 ph, 50 Hz 600 V, 3 ph, 50/60 Hz	5/8 in. (16 mm)	1/2 in. (12 mm)	60 A	6.2 kW	SL60QD Air Pressure - 75 psi (5.2 bar) Consumption - 6.7 cfm (190 l/m)
Duty Cycle	Amperage draw	Maximum Cut	Dimensions L x W x H	Weight	
40% @ 60 A 60% @ 50 A 100% @ 30 A	45 A @ 230 V, 1 ph 24 A @ 230 V, 3 ph 16 A @ 460 V, 3 ph	1 in. (25 mm)	24 x 12 x 15 in. (610 x 305 x 381 mm)	43 lbs. (19.5 kg)	

### Ordering Information

Cutmaster 58, 20 ft. (6 m), SL60QD, 208-230 VAC	1-5830-1	Cutmaster 58, 20 ft. (6 m), SL60QD, 400-480 VAC	1-5830-2
Cutmaster 58, 20 ft. (6 m), SL60QD, 600 VAC	1-5830-5	Cutmaster 58, 50 ft. (15.2 m), SL60QD, 208-230 VAC	1-5831-1
Cutmaster 58, 50 ft. (15.2 m), SL60QD, 400-480 VAC	1-5831-2	Cutmaster 58, 50 ft. (15.2 m), SL60QD, 600 VAC	1-5831-5
Cutmaster 58 Power Supply, 208-230 VAC	3-5830-1	Cutmaster 58 Power Supply, 400-480 VAC	3-5830-2
Cutmaster 58 Power Supply, 600 VAC	3-5830-5		

Cutmaster 58 systems include: Power supply, torch, spare parts kit, input power cable, work cable and clamp.

## Cutmaster® 60i

The new frontier in plasma

 [esab.com/beast](http://esab.com/beast)



- Packed with power and offering the highest power-to-weight ratio in its class, the Cutmaster® 60i with SL60QD 1Torch® also has best-in-class cutting arc length and the most empowering and engaging user experience no matter the application
- Built for portability and durability with the integral multi-handle design, available in either a 1 phase or 3 phase unit
- Cutmaster MechPak is also available for easy integration into semi-automatic cutting processes
- 50% Duty Cycle at 60A with automatic multi-voltage detection from 208-480V
- Industrial SL60QD 1Torch quick disconnect with ATC® (Advanced Torch Connector) allowing selective replacement of either the torch handle assembly or the torch leads, using the patented SureLok® technology
- Up to 3/4 in. (20 mm) recommended cut capacity with maximum sever of 1-1/2 in. (38 mm) and 3/4 in. (20 mm) pierce capability
- High-visibility, oversized display with gas optimizer technology and consumables end-of-life indicator, makes setup and usage simple and productive
- Cutmaster Black Series electrode included for up to 60% longer life of consumable parts
- Industry leading 4-year warranty on power supply and 1-year warranty on torch

CUTTING MACHINES

### Specifications

Input Voltage	Recommended Generator Size	Open Circuit Voltage	Amperage Output
208 – 480 VAC +/- 10%, 1 ph or 3 ph, 50/60 Hz	15 kW (full output)	300 V	10 – 60 A, continuously adjustable
Rated Duty Cycle	Amperage Draw	Input Power Cable and Plug	Work Lead with Ground Clamp
50% @ 60 A 60% @ 50 A 100% @ 40 A	43 A @ 208 V 1 ph / 26 A @ 208 V 3 ph 39 A @ 230 V 1 ph / 23 A @ 230 V 3 ph 19 A @ 480 V 1 ph / 11 A @ 480 V 3 ph	9 ft. (2.7 m) 1 ph 8 AWG 3/C with NEMA 6-50P plug 9 ft. (2.7 m) 3 ph 12 AWG 4/C cable without plug	20 ft. (6 m) #8 work cable with 50 mm connection
Recommended Cut	Maximum Sever	Pierce Rating	Gas Requirements
up to 3/4 in. (20 mm)	1-1/2 in. (38 mm)	3/4 in. (20 mm)	Compressed air
SL60QD Torch Duty Cycle	Air Flow Requirements (cutting & gouging)	Operating Input Air Pressure Range	Operating Temperature Range
100% at 60 A @ 400 scfh air flow	300 – 500 cfm (142 – 235 l/m)	90 – 125 psi (6.2 – 8.6 bar)	32 – 122° F (0° - 50° C)
Torches	Power Supply Gas Filtering Ability	Dimensions L x W x H	Weight
SL60QD 1Torch (supplied) SL60/SL100 1Torch SL100 Mechanized 1Torch SL100SLV Automated 1Torch	Particulates to 5 Microns	21.12 x 7.85 x 14.15 in. (536 x 199 x 593 mm)	37 lbs. (16.8 kg)

### Ordering Information

Cutmaster 60i, 1 ph with SL60QD 1Torch 20 ft. (6.1 m) 75° Head	1-5630-1X
Cutmaster 60i, 1 ph with SL60QD 1Torch 50 ft. (15.2 m) 75° Head	1-5631-1X
Cutmaster 60i, 1 ph Power Supply Only	3-5630-1X
Cutmaster 60i, 3 ph with SL60QD 1Torch 20 ft. (6.1 m) 75° Head	1-5630-2X
Cutmaster 60i, 3 ph with SL60QD 1Torch 50 ft. (15.2 m) 75° Head	1-5631-2X
Cutmaster 60i, 3 ph Power Supply Only	3-5630-2X

Cutmaster 60i systems include: power supply, SL60QD 75° torch with lead, 20 ft. (6.1 m) work lead with ground clamp, spare parts kit, operating manual, and filter wrench.

Cutmaster 60i is compatible with all 1Torch® ATC torch connections.

### SL60 Consumables

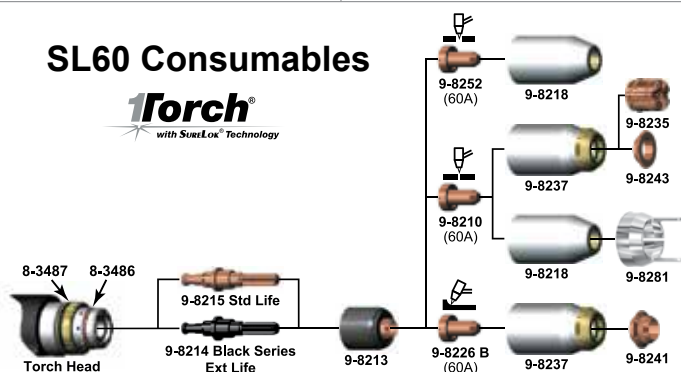

## Cutmaster® 82

Medium/heavy-duty, portable plasma cutting system



- The Cutmaster® 82 weighs in at only 43 lbs. (19.5 kg) while still offering superior cutting power
- Cuts 3/4 in. (20 mm) with a maximum capability of 1-1/2 in. (40 mm)
- Versatile 1Torch® with ATC® disconnect makes it easy to add lead extensions or convert to a machine torch
- True Guard roll bar provides easy transportation and protection for unmatched durability
- Auto Pilot Restart feature instantly reignites the pilot arc while cutting expanded metals

### Specifications

Input Voltage	Recommended Cut	Pierce Rating	Output Power	Max Amperage Output	Torch
208 – 230/460 V, 1/3 ph, 50/60 Hz 400 V, 3 ph, 50 Hz 600 V, 3 ph, 50/60 Hz	3/4 in. (20 mm)	5/8 in. (15 mm)	9 kW	80 A	SL60 Air Pressure - 70 psi (4.8 bar) 6.7 cfm (190 l/m)
Maximum Cut	Amperage Draw	Duty Cycle (@ 104°F/40°C)	Dimensions L x W x H	Weight	
1.5 in. (40 mm)	72 A @ 230 V, 1 ph 39 A @ 230 V, 3 ph 21 A @ 460 V, 3 ph	40% @ 80 A 60% @ 65 A 100% @ 55 A	24 x 12 x 15 in. (610 x 305 x 381 mm)	43 lbs. (19.5 kg)	

### Ordering Information

Cutmaster 82, SL60 75°, 20 ft. (6.1 m), 208-230 V, 1 ph	1-1130-1	Cutmaster 82, SL60 75°, 20 ft. (6.1 m), 460 V, 3 ph	1-1130-2
Cutmaster 82, SL60 75°, 20 ft. (6.1 m), 600 V, 3 ph	1-1130-5	Cutmaster 82, SL60 75°, 50 ft. (15.2 m), 208-230 V, 1 ph	1-1131-1
Cutmaster 82, SL60 75°, 50 ft. (15.2 m), 460 V, 3 ph	1-1131-2	Cutmaster 82, SL60 75°, 50 ft. (15.2 m), 600 V, 3 ph	1-1131-5

Cutmaster 82 systems include: power supply, torch, spare parts kit, input power cable, work cable and clamp, and an instructional DVD.

## Cutmaster® 102

Heavy-duty, portable plasma cutting system



- The Cutmaster® 102 weighs in at 62 lbs. (28 kg) and provides 100 A of cutting power
- This unit combined with the 1Torch® has a maximum cut capacity of 1-3/4 in. (45 mm)
- Versatile 1Torch with ATC® disconnect makes it easy to add lead extensions or convert to a machine torch
- True Guard roll bar provides easy transportation and protection for unmatched durability
- Auto Pilot Restart feature instantly reignites the pilot arc while cutting expanded metals

### Specifications

Input Voltage	Recommended Cut	Pierce Rating	Output Power	Max Amperage Output	Torch
208 – 230/460 V, 1/3 ph, 50/60 Hz 400 V, 3 ph, 50 Hz 600 V, 3 ph, 50/60 Hz	1 in. (25 mm)	3/4 in. (20 mm)	12 kW	100 A	SL100 Air Pressure - 70 psi (4.8 bar) 7.5 cfm (212 l/m)
Amperage Draw	Maximum Cut	Duty Cycle	Dimensions L x W x H	Weight	
95 A @ 230 V, 1 ph 45 A @ 230 V, 3 ph 29 A @ 460 V, 3 ph	1 3/4 in. (45 mm)	60% @ 100 A 80% @ 80 A 100% @ 70 A	30 x 12 x 15 in. (762 x 305 x 381 mm)	62 lbs. (28.1 kg)	

### Ordering Information

Cutmaster 102, SL100 75°, 20 ft. (6.1 m), 208-230 V, 1 ph	1-1330-1	Cutmaster 102, SL100 75°, 20 ft. (6.1 m), 460 V, 3 ph	1-1330-2
Cutmaster 102, SL100 75°, 20 ft. (6.1 m), 600 V, 3 ph	1-1330-5	Cutmaster 102, SL100 75°, 50 ft. (15.2 m), 208-230 V, 1 ph	1-1331-1
Cutmaster 102, SL100 75°, 50 ft. (15.2 m), 460 V, 3 ph	1-1331-2	Cutmaster 102, SL100 75°, 50 ft. (15.2 m), 600 V, 3 ph	1-1331-5

Cutmaster 102 systems include: power supply, torch, spare parts kit, input power cable, work cable and clamp, and an instructional DVD.



## Cutmaster® 152

Extra heavy-duty cutting system



- The Cutmaster® 152, weighing only 62 lbs. (28 kg), offers multi-voltage 1-or 3-phase input capability and provides 120 A of cutting power for a 1-1/4 in. (30 mm) recommended cut and 2 in. (50 mm) maximum cut
- Comes standard with the 1Torch® providing you with the well known comfort and reliability famous throughout the industry
- Front Panel LEDs indicate status conditions for maximum efficiency and storage compartment for convenient access to spare parts and consumables
- True Guard roll bar provides easy transportation and protection for unmatched durability
- Auto Pilot Restart feature instantly reignites the pilot arc while cutting expanded metals

### Specifications

Input Voltage	Recommended Cut	Pierce Rating	Output Power	Max Amperage Output	Torch
208 – 230/460 V, 1/3 ph, 50/60 Hz 400 V, 3 ph, 50 Hz 600 V, 3 ph, 50/60 Hz	1-1/4 in. (30 mm)	1 in. (25 mm)	15.4 kW	120 A	SL100 Air Pressure - 70 psi (4.8 bar) 7.5 cfm (212 l/m)
Amperage Draw	Maximum Cut	Duty Cycle	Dimensions L x W x H	Weight	
120 A @ 230 V, 1 ph 56 A @ 230 V, 3 ph 37 A @ 460 V, 3 ph	2 in. (50 mm)	80% @ 120 A 100% @ 100 A	30 x 12 x 15 in. (762 x 305 x 281 mm)	62 lbs. (28.1 kg)	

### Ordering Information

Cutmaster 152, SL100 75°, 20 ft. (6.1 m), 208–230 V, 1 ph	1-1730-1	Cutmaster 152, SL100 75°, 20 ft. (6.1 m), 460 V, 3 ph	1-1730-2
Cutmaster 152, SL100 75°, 20 ft. (6.1 m), 600 V, 3 ph	1-1730-5	Cutmaster 152, SL100 75°, 50 ft. (15.2 m), 208–230 V, 1 ph	1-1731-1
Cutmaster 152, SL100 75°, 50 ft. (15.2 m), 460 V, 3 ph	1-1731-2	Cutmaster 152, SL100 75°, 50 ft. (15.2 m), 600 V, 3 ph	1-1731-5

Cutmaster 152 systems include: power supply, torch, spare parts kit, input power cable, work cable and clamp, and an instructional DVD.

## PAK® 200i

Manual air-plasma cutting and gouging system



- Capable of hand cutting at 200 A with the ability to cut up to 2-3/4 in. (70 mm) on mild steel; at full output this unit will cut 10 ipm (254 mm/min) on 2 in. (51 mm) carbon steel
- 100% duty cycle at full output
- Dual Gas Capability – the dual gas system ensures superior quality and performance on ferrous and non-ferrous materials (Plasma Gas: Air, ArH2, Secondary Gas: Air, N2)
- High Gouging Removal Rate – with the ability to remove up to 25 lbs. (11.3 kg) of carbon steel per hour
- Tip Saver for Optimal Tip Life – this ensures that any accidental contact between the tip and the work at high power levels will not damage the tip

All PAK 200i systems include power supply, torch and leads, spare parts kit, 25 ft. (7.6 m) work cable and clamp, and torch coolant.

### Specifications

Input Voltage	Output Power	Recommended Cut	Maximum Cut	Pierce Rating	Duty Cycle	Torch
380 – 415 V, 3 ph, 50/60 Hz / 480 V, 3 ph, 50/60 Hz	40 kW	1-1/2 in. (40 mm)	2 3/4 in. (70 mm)	1 1/4 in. (32 mm)	100% @ 200 A	PCH200 Hand/Machine
Output Current	Amperage Draw	Specifications	Dimensions L x W x H	Weight		
35-200 A	60 A @ 380 V 57 A @ 400 V 47 A @ 480 V	Plasma Gas - Air, ArH2, N2 Secondary Gas - Air, N2	40.6 x 48 x 27.5 in. (1031 x 1219 x 698 mm)	490 lbs. (222 kg) w/o torch Fully Assembled Power Supply		

### Ordering Information

PAK 200i - 70° Torch, 25 ft. (7.6 m), 480 V	1-2239	PAK 200i - 70° Torch, 50 ft. (15.2 m), 480 V	1-2240	PAK 200i - 90° Torch, 25 ft. (7.6 m), 480 V	1-2241
PAK 200i - 70° Torch, 25 ft. (7.6 m), 400 V	1-2245	PAK 200i - 70° Torch, 50 ft. (15.2 m), 400 V	1-2246	PAK 200i - 90° Torch, 25 ft. (7.6 m), 400 V	1-2247
PAK 200i - 90° Torch, 50 ft. (15.2 m), 480 V	1-2242	PAK 200i - 90° Torch, 50 ft. (15.2 m), 400 V	1-2248	PAK 200i - 180° Torch, 25 ft. (7.6 m), 480 V	1-2243
PAK 200i - 180° Torch, 25 ft. (7.6 m), 400 V	1-2249	PAK 200i - 180° Torch, 50 ft. (15.2 m), 480 V	1-2244	PAK 200i - 180° Torch, 50 ft. (15.2 m), 400 V	1-2250

## 1TORCH® SL60

Light/medium-duty torch (20 – 80 A)



- As a replacement (RPT®) torch, the 1Torch® has the ability to work on the majority of plasma power supplies on the market today
- Its unique design allows the 1Torch the ability to work with high frequency, touch, CD, and moving parts (blow back) start systems

### Ordering Information

SL60, 75°, 20 ft. (6.1 m) Standard RPT Connect	7-5200	SL60, 90°, 20 ft. (6.1 m) Standard RPT Connect	7-5261
SL60, 75°, 50 ft. (15.2 m) Standard RPT Connect	7-5201	SL60, 90°, 50 ft. (15.2 m) Standard RPT Connect	7-5262
SL60, 75°, 20 ft. (6.1 m) ATC Connect	7-5204	SL60, 90°, 20 ft. (6.1 m) ATC Connect	7-5260
SL60, 75°, 50 ft. (15.2 m) ATC Connect	7-5205	SL60, 90°, 50 ft. (15.2 m) ATC Connect (lead extension 7-7545 required)	7-5260
SL60QD Torch and Lead 20 ft. (6.1 m) 75° Head	7-5604	SL60QD Torch and Lead 50 ft. (15.2 m) 75° Head	7-5605

## 1TORCH® SL100

Medium/heavy-duty torch (20 – 120 A)



- Hand torches offer ergonomic handles with easy-to-use trigger release that provides comfort during prolonged use
- 75° and 90° heads offer operators a choice of positions

### Ordering Information

SL100, 75°, 20 ft. (6.1 m) Standard RPT Connect	7-5202	SL100, 90°, 20 ft. (6.1 m) Standard RPT Connect	7-5264
SL100, 75°, 50 ft. (15.2 m) Standard RPT Connect	7-5203	SL100, 90°, 50 ft. (15.2 m) Standard RPT Connect	7-5265
SL100, 75°, 20 ft. (6.1 m) ATC Connect	7-5206	SL100, 90°, 20 ft. (6.1 m) ATC Connect	7-5263
SL100, 75°, 50 ft. (15.2 m) ATC Connect	7-5208	SL100, 90°, 50 ft. (15.2 m) ATC Connect (lead extension 7-7545 required)	7-5263

## 1TORCH® Mechanized SL100, Automation SL100SV

Medium/heavy-duty torch (20 – 120 A)



SL100 Mechanized



SL100SV Automated

- Only 34 consumable parts cover the full range of cutting and gouging up to 120 A
- Stocking parts for a fleet of plasma units can be simplified using the 1Torch®

### Ordering Information

SL100 Mechanized, 180°, 25 ft. (7.6 m), Standard	7-5209	SL100 Mechanized, 180°, 50 ft. (15.2 m), Standard	7-5210
SL100 Mechanized, 180°, 25 ft. (7.6 m), Shielded	7-5211	SL100 Mechanized, 180°, 50 ft. (15.2 m), Shielded	7-5212
SL100 Mechanized, 180°, 5 ft. (1.5 m), Standard ATC Connect	7-5213	SL100 Mechanized, 180°, 10 ft. (3.0 m), Standard ATC Connect	7-5214
SL100 Mechanized, 180°, 25 ft. (7.6 m), Standard ATC Connect	7-5215	SL100 Mechanized, 180°, 50 ft. (15.2 m), Standard ATC Connect	7-5216
SL100 Mechanized, 180°, 5 ft. (1.5 m), Shielded ATC Connect	7-5219	SL100 Mechanized, 180°, 10 ft. (3.0 m), Shielded ATC Connect	7-5220
SL100 Mechanized, 180°, 25 ft. (7.6 m), Shielded ATC Connect	7-5221	SL100 Mechanized, 180°, 50 ft. (15.2 m), Shielded ATC Connect	7-5222
SL100SV Automated, 180°, 25 ft. (7.6 m), Standard ATC Connect	7-4001	SL100SV Automated, 180°, 35 ft. (10.6 m), Standard ATC Connect	7-4002
SL100SV Automated, 180°, 50 ft. (15.2 m), Standard ATC Connect	7-4003	SL100SV Automated, 180°, 75 ft. (22.8 m), Standard ATC Connect	7-4004
SL100SV Automated, 180°, 100 ft. (30.4 m), Standard ATC Connect	7-4005		

## Torch Connection Options - Remote Control

The diagrams below show the different torch connections with remote connection options.

### Standard RPT (Replacement Torch) Connection

(Note: Remote control is either 7-3460 Remote Pendant Control or is user supplied.)

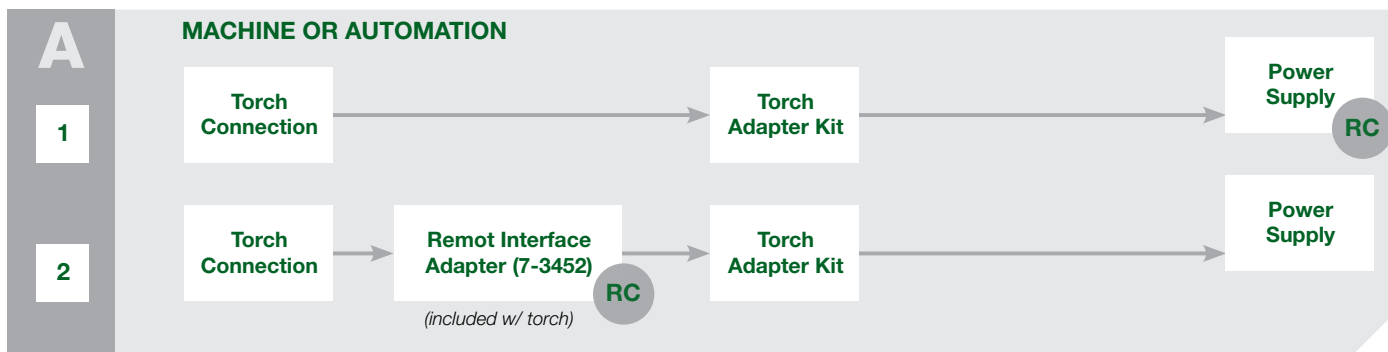

RC = Remote Control

### ATC (Advanced Torch Connector) Torch Connection

(Note: Remote control is either 7-3460 Remote Pendant Control or is user supplied.)

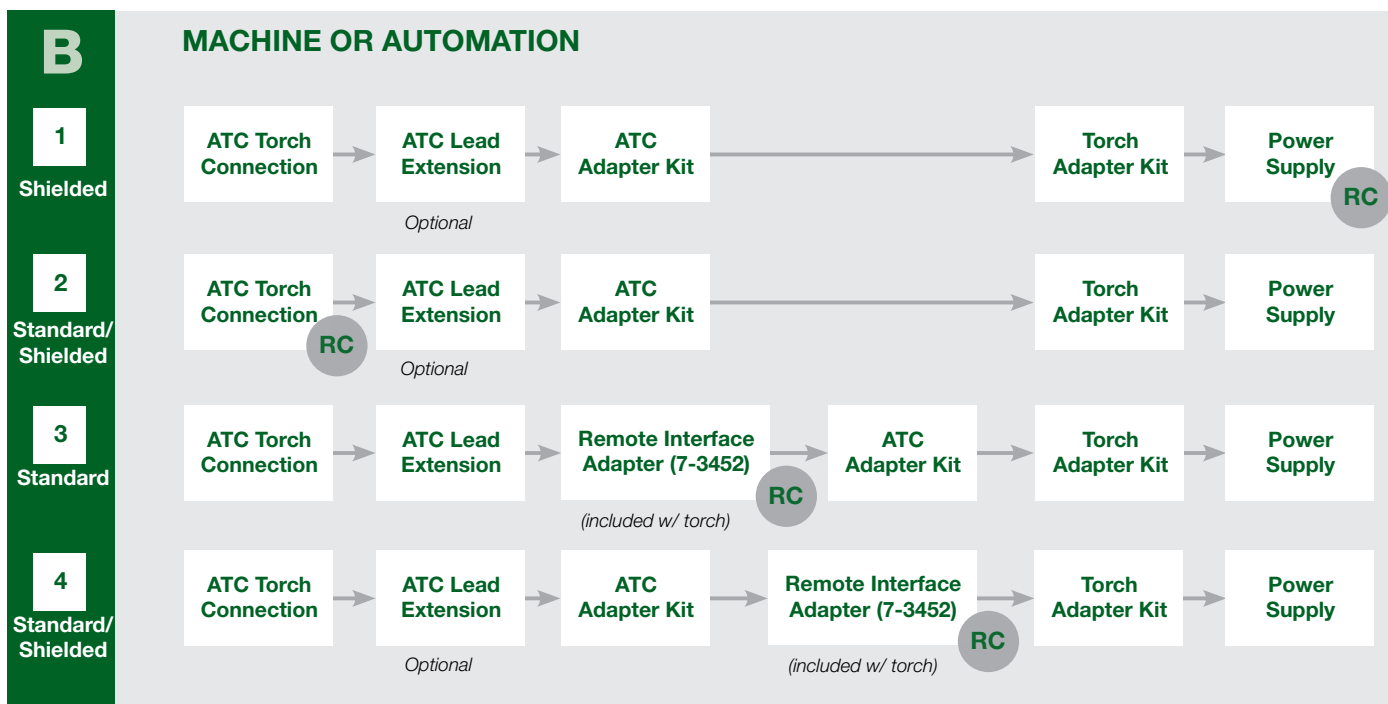

RC = Remote Control

PLASMA TORCHES

## Plasma Torch Adapter Kits Selection

Listed below is the Adapter Kit selection charts for the Hand 1Torch® RPT® torch.

Manufacturer	Power Supply Model	Part No.
<b>ESAB®</b>	PCM-SMi, 500i, 625i, PCS-43	7-3425
	PCS-53, 80, 90	7-3435
	ESP-100i	7-3426
	PCM-750i, 875, 1000i, 1125	7-3429
	Sidewinder 30,55,105	7-3434
	Powercut 650	7-3464
	Powercut 875, 1125	7-3465
	Powercut 1250, 1500	7-3462
<b>HARRIS®</b>	System 50, 65 and 100	7-3439
<b>HOBART®</b>	Smoothcut II 35A, 60A, and 100A	7-3427
<b>HYPERTHERM®</b>	Max 40, HT40 (H/F Start) Max 70, 80, 100 (w/ & w/o Q.D.)	7-3430
	Max 42*, 43*, 40cs*, Powermax 600*, 800*, 900* (w/ Q.D.)	7-3454
	Powermax 1100*	7-3455
	Powermax 1000*, 1250*	7-3461
	Max 40cs* (w/o Q.D.)	7-3476
	Powermax 380*	7-3477
	Powermax 600* (w/o Q.D.)	7-3480
	Powermax 800*, 900* (w/o Q.D.)	7-3481
	Powermax 1650*	7-3483
	Powermax 350*	7-3484
<b>L TEC®</b>	PCM-31, SMi, 32i/34i, VPi PCM-500i, 625i, PCS-80i	7-3425
	PCM-50A, 70, 80, 52i/54i, 82i/84i ESP-100i, PCM-50, PCM-100 (Single Gas) PCM-50, P-MC-100 (Dual Gas)	7-3426
	PCS-40	7-3430
	PCM-750i, 1000i	7-3435
	PCM-101	7-3436

Manufacturer	Power Supply Model	Part No.
<b>LINCOLN®</b>	Procut 60	7-3431
<b>MILLER®</b>	Plazcut 60†/Zipcut	7-3432
	Spectrum 250D, 500, 750	7-3433
	Spectrum 700, 1000,1250,PLUS	7-3430
	Spectrum 3080*	7-3456
	Spectrum 650*, 701*, 2050*	7-3457
	Spectrum 300*	7-3476
	Spectrum 375*	7-3477
	Spectrum 625*	7-3478
<b>OTHERS</b>	OTC: D-5000 and D-7000 PTRON: P-TRON 75 and 100 Daihen: MRAT-70 Multiquip: PCX50SS	7-3437
<b>SMITH®</b>	Powerpro 55 and 75	7-3487
<b>THERMAL DYNAMICS®</b>	PAK 3XR, 5XT, 6XR, 7XR, 625XR, 750XR	7-3446
	PAK 8XR, 10XR, 1000XR, 1250XR, PakMaster 75, 100	7-3434
	PakMaster 50XL/XLP, 75XL/XLP, 100XL/XLP Cutmaster 50, 75, 80XL, 100	7-3447
	PakMaster 25, 38XL, EconoPAK 25, Drag-Gun 38, PAK 4Xi, 6Xi, PAK 2XT, Dynapak 110	7-3443
	PakMaster 50 w/Smart Torch (Q.D)	7-3445
	EconoPAK 50	7-3449
	EconoPAK 100	7-3450
	PAK 5	7-3444
	PAK 10	7-3436

\* Non-HF Systems.

† The Miller PlazCut machines with Serial Numbers beginning JE are not compatible with 1Torch® RPT Torches.

NOTES: Each Adapter Kit includes connection fitting, electrical connectors and installation instruction sheets for the selected power supply.

ESAB, L-TEC and Powercut are registered trademarks of ESAB AB; LINCOLN and Procut are registered trademarks of Lincoln Electric Co.; HYPERTHERM, Max and Powermax are registered trademarks of Hypertherm, Inc.; MILLER and Spectrum are registered trademarks of Miller Electric Mfg. Co.; none of the afore mentioned registered trademarks are in any way affiliated with Thermal Dynamics or Victor Technologies; Thermal Dynamics, PAK, Cutmaster, PakMaster, EconoPAK, Dynapak and Drag-Gun are registered trademarks of ESAB Group Inc.

# 1TORCH® Consumables

## SL60 Consumables

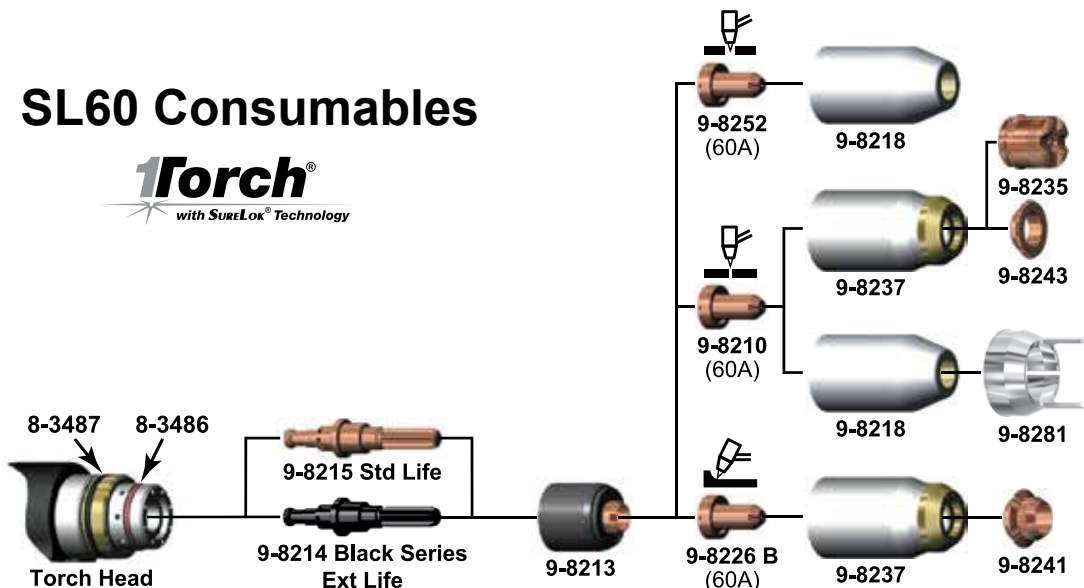

Description	Part Number	
O-Ring	8-3487	
O-Ring	8-3486	
O-Ring Lubricant	8-4025	
Electrode	9-8215	
Start Cartridge	9-8213	
Heavy-Duty Start Cartridge (non HF systems only)	9-8277	
Drag	Tip, 20A, Drag	9-8205
	Tip, 30A, Drag	9-8206
	Tip, 40A, Drag	9-8207
	Tip, 60A, Drag	9-8252
Standoff	Tip, 40A, Standoff	9-8208
	Tip, 50/55A, Standoff	9-8209
	Tip, 60A, Standoff	9-8210
	Tip, 70A, Standoff	9-8231
	Tip, 80A, Standoff	9-8211
	Tip, 90/100A, Standoff	9-8212
Gouge	Tip, A, Gouging	9-8225
	Tip, B, Gouging	9-8226
	Tip, C, Gouging	9-8227
	Tip, D, Gouging	9-8228
	Tip, E, Gouging	9-8254
Shield Cup	9-8218	
Shield Cup Body, MaximumLife®	9-8237	

Description	Part Number	
Drag	Shield Cap, Drag, 40A	9-8244
	Shield Cap, Drag, 50-60A	9-8235
	Shield Cap, Drag, 70-100A	9-8236
	Shield Cap, Drag, 120A	9-8258
Mechanized	Shield Cap, Mechanized, 40A	9-8245
	Shield Cap, Mechanized, 50-60A	9-8238
	Shield Cap, Mechanized, 70-100A	9-8239
	Shield Cap, Mechanized, 120A	9-8256
Shield Cap, Deflector	9-8243	
Shield Cap, Gouging	9-8241	
Ohmic Clip	9-8224	
Ohmic clip for manual torches	9-8259	
Spare Parts Kit, 30A	5-2550	
Spare Parts Kit, 40A	5-2551	
Spare Parts Kit, 50/55A	5-2552	
Spare Parts Kit, 60A	5-2553	
Spare Parts Kit, 70A	5-2554	
Spare Parts Kit, 80A	5-2555	
Spare Parts Kit, 90/100A	5-2556	

Note: All Spare Parts Kits above include ten (10) tips, five (5) electrodes and one (1) start cartridge.

PLASMA TORCHES

## 1TORCH® Consumables Parts Application Guide

For SL60®/SL100® Manual Cutting and Gouging Operations.



**DRAG TIP CUTTING** The preferred method of cutting light gauge metal up to 1/4 in. (6 mm) thickness. Produces the best cut quality narrowest kerf width, fastest cutting speeds, and with little to no distortion. Traditional drag cutting was limited to 40 Amps or less; now with Thermal Dynamics TRUE Cut Drag Tip Series™ technology, it is possible to cut up to 60 Amps. For best results, use the Shield Cup with the torch tip in direct contact with the work (up to 60 Amps).



**DRAG SHIELD CUTTING** This is an operator-friendly method of cutting between 70 to 120 Amps while maintaining a constant standoff distance. For metal thickness greater than 1/4 in. (6 mm), simply drag the shield cap in contact with the work piece. Use the shield cup body with the appropriate drag shield cap matching the current level being used. This method is not recommended for cutting light-gauge sheet metal.



**STANDOFF CUTTING** The preferred method of cutting metal thicker than 1/4 in. (6 mm) and at current levels above 60 Amps. Provides maximum visibility and accessibility. Shield cup for 'standoff' cutting (with the torch tip 1/8 in. (3 mm) to 1/4 in. (6 mm) from the work piece). Use the shield cup body together with the deflector for extended parts life and improved resistance to reflect heat. This combination provides cutting results similar to the single piece shield cup, as well as easy changeover to gouging or drag shield cutting.



**GOUGING** A simple method of metal removal by angling the torch to a lead angle of 35°-45°, and using a gouging tip. While maintaining a constant standoff distance, this allows for only a partial penetration into the work, thus removing metal from the surface. The amount of current, travel speed, standoff distance, lead angle, and tip size will determine the amount of material removed and the profile of the gouge. You can use the shield cup body with either the gouging shield cap or the shield deflector. Also, you can use the single piece shield cup.

Gouging Profiles			
	Output Range	Depth	Width
	40A (MAX)	Shallow	Narrow
	50-100A	Deep	Narrow
	60-120A	Moderate	Moderate
	60-120A	Shallow	Wide

## Plasma Accessories



### Cutting Guide Cutting Kit (Deluxe)

Part Number: 7-8910

Cuts circles from 2-1/8 in. (54 mm) to 41-1/2 in. (1054 mm) with proper cutting attachments. Includes easy add-on attachments to fit most Thermal Dynamics torches for precise straight line, circle cutting and beveling. Carrying case, radius/roller kit (7-7501), circle cutting guide (7-3291), magnetic pivot, suction pivot included.



### Circle Guide Cutting Kit

Part Number: 7-3291

Cuts 2-1/8 in. (54 mm) to 27-3/4 in. (705 mm) circles (using magnetic attachment) when cutting or beveling is required. For use with most Thermal Dynamics torches.



### Radius/Roller Cutting Guide Kit

Part Number: 7-7501

This easy-to-use guide cuts circles from 3 in. (76 mm) up to 28-3/4 in. (730 mm). Maintains a consistent height off the work piece whether you are using the circle cutting attachment for cutting circles or the roller guide feature to improve your straight-line cutting. Both novices and experts will see noticeable improvement in quality, speed, and parts life. Cutting Bushing (7-2915) for use with the SL40 torch.



### Straight Line Cutting Guide

Part Number: 7-8911

This versatile, straight line cutter is for hand held systems and it cuts vertical, 90° or bevel cuts. Magnetic mounts ensure placement and ease of use. Optional suction plates available for non-magnetic applications (i.e. aluminum and stainless steel). Includes: 4 ft. (1.2 m) standard rail torch holder and bushing heavy duty magnets (2 ea.) slide assembly wheels and fasteners. optional 4 ft. (1.2 m) extensions (9-7971) available.



### Standoff Cutting Guides

Part Number: 9-0090 (SL40 Torch)  
Part Number: 9-8251 (SL60/SL100 Torch, 40A)  
Part Number: 9-8281 (SL60/SL100 Torch, 60-100A)

Available for SL40 torch, SL60 and SL100 torches.



### Cutting Guide Bushing

Part Number: 7-2915

Designed to fit the SL40 torch specific to the Cutmaster 42 system. This bushing accommodates the use of the SL40 torch with the cutting guides.



### Leather Lead Covers

Part Number: 9-1258 [15 ft. (4.6 m)]  
Part Number: 9-1260 [20 ft. (6.1 m)]  
Part Number: 9-1270 [25 ft. (7.6 m)]  
Part Number: 9-1280 [50 ft. (15.2 m)]

These lead covers are suitable for both 1Torch and SureLok leads. Snaps make it easy to install. For wider torches, consider snapping two covers together width wise.



### Remote Pendant Control

Part Number: 7-3460

20 ft. (6.1 m) Remote Pendant Control for your mechanized application.





### ATC Lead Extensions

Part Number: 7-7544 [15 ft. (4.6 m)]  
Part Number: 7-7545 [25 ft. (7.6 m)]  
Part Number: 7-7552 [50 ft. (15.2 m)]

Available for any system using hand or mechanized 1Torch with ATC Quick Disconnect. Leads Extensions enable you to customize your lead length to suit the cutting job.

## Plasma Accessories

		
<p><b>Single Stage Air Filter Kit</b> Part Number: 7-7507</p> <p>(Filter Body 9-7740, Hose 9-7742, Filter Element 9-7741). For use with shop compressed air systems, this in-line filter will not allow moisture or water to pass through the filter element even if it becomes completely saturated. This hi-tech filter element actually blocks the absorption of water to increase performance and improve consumable parts life.</p>	<p><b>Two Stage Air Filter</b> Part Number: 9-9387</p> <p>First Stage Element 9-1021, Second Stage Element 9-1022). The Two Stage Air Filter will remove moisture and contaminants from the air stream when using compressed air. The filter is capable of filtering to at least 5 microns. The filter assembly is pre-assembled and need only be installed on the power supply.</p>	<p><b>Multi-Purpose Cart</b> Part Number: 7-8888</p> <p>Designed for most portable manual cutting systems or any similar sized systems. This rugged steel cart has easy rolling 8 in. (203 mm) diameter wheels along with 3" (76 mm) front mounted casters. This cart also serves as an excellent showroom display stand.</p>
<p><b>Trigger Guard Guides</b> Part Number: 9-8420</p> <p>1Torch (SL60 and SL100). These guards offer additional protection from accidental activation or damage to the torch switch.</p>	<p><b>Hand Pendant Extension</b> Part Number: 7-7744</p> <p>25 ft. (7.6 m).</p>	<p><b>Automation Interface Kit</b> Part Number: 9-8311</p> <p>For Cutmaster TRUE Series (52, 82, 102, 152). This kit adds a divided low volt output for height controls that can use 50:1 arc voltage. Required for the Thermal Dynamics SC-11 height control.</p>
<p><b>CNC Harness Cable</b> Part Number: 9-9385</p> <p>Assembly of electrical cables or wires which transmit signals or electrical power.</p>	<p><b>CNC Interface Cable</b> Part Number: 9-1008 [25 ft. (7.6 m)] Part Number: 9-1010 [35 ft. (10.6 m)] Part Number: 9-1011 [50 ft. (15.2 m)]</p> <p>For "Start/Stop" and "OK to Move" Only.</p>	<p><b>Pinion Assembly</b> Part Number: 7-2827</p> <p>1-3/8 in. (35 mm) Diameter</p>

# // PPE & ACCESSORIES









# MISSION READY. FOR THE ACCOMPLISHED.

The best welders deserve the best equipment. And when it comes to choosing a helmet, Sentinel is it – with ergonomic HALO™ headgear, external grind mode access, a hypervisible control panel, and an ultra-clear true-color lens. To learn more about the incredible Sentinel helmet and find a distributor near you, go to [esab.com/sentinel](https://esab.com/sentinel).

## SENTINEL™

# CONTENTS

## WELDING HELMETS

Sentinel™ A50 .....	211
Warrior™ Tech .....	213
Globe-Arc .....	213
FR Jersey .....	214
FR Winter.....	214
FR Fleece .....	214

## PROTECTIVE CLOTHING

Proban Welding Jacket .....	215
Shop Coat .....	215
Welding Apron .....	215

## GLOVES

Curved MIG (GMAW) Gloves.....	216
Heavy-Duty Black Gloves.....	216
Heavy-Duty Aluminized Gloves.....	216
Curved TIG (GTAW) Gloves .....	217
Professional TIG (GTAW) Gloves .....	217

## EYE PROTECTION

Safety Glasses.....	218
Goggles .....	218

## PPE ACCESSORIES

Proban Hood .....	219
Hard Hat .....	219
Welder's Cap .....	219
Insulated Helmet Liner .....	219
Leather Helmet Pad.....	219
Easy-Lite.....	219

## Sentinel™ A50

Shade 5-13 auto-darkening welding helmet



- Revolutionary shell design - high impact resistance nylon
- Halo™ headgear - ergonomic, infinitely-adjustable 5 point head gear provides extreme comfort and balance
- Low-profile design, central pivot point allows for maximum head clearance while helmet is in the up position.
- 3.93 x 2.36 in. (100 x 60 mm) viewing area
- 1/1/1/2 –5-13 ADF
- Color touch screen control panel with 8 separate memory settings and externally activated shade 4 Grind Button
- Hard hat adapter option available for use with ESAB hard hat

[esab.com/sentinel](http://esab.com/sentinel)

### Specifications

Cartridge Dimensions	Viewing Area	Lens Shade	Sensors	
5.2 x 4.5 x 0.35 in. (133 x 114 x 9 mm)	3.93 x 2.36 in. (100 x 60 mm)	Shade 5-8/9-13	4	
Switch Time	Classification	Power Supply	Standards	Weight
1/25,000 s from light to dark	1/1/1/2	Solar cell plus battery replaceable. (2 x CR2450 lithium). Alerts when low battery.	DIN Plus, CE, EN 175, EN 379, EN 166, ANSI Z87.1, CSA Z94.3, AS/NZS 1338.1	1.4 lbs. (640 g)

### Ordering Information

SENTINEL A50 Welding Helmet	0700000800
-----------------------------	------------

### Options & Accessories

1	Front Cover Lens Clear HD	0700000823
1	Front Cover Lens Amber HD	0700000824
1	Front Cover Lens Clear	0700000802
1	Front Cover Lens Amber	0700000803
2	SENTINEL Helmet Shell	0700000804
3	Auto-Darkening Filter (including 2 x CR2450 lithium battery)	0700000806
4	2 x CR2450 lithium battery	0700000807
5	Inside Cover Lens	0700000808
6	Headgear Assembly (including sweat bands)	0700000809
7	Front Sweat Band	0700000810
8	Headgear	0700000811
9	Rear Sweat Band	0700000812
10	Magnifying Glass +1.0 Diopter	0367951001
10	Magnifying Glass +1.5 Diopter	0367951002
10	Magnifying Glass +2.0 Diopter	0367951003
10	Magnifying Glass +2.5 Diopter	0367951004
11	Sentinel Hard Hat Adapter*	0700000619
12	Concept Hard Hat Yellow	0700000052
x	Sentinel Bandana	0700000821

\*For use with Concept Hard Hat. For details on assembly, please see separate user guide. Hard Hat Adapter replaces Headgear 0700000809 for the Sentinel A50 with Hard Hat combination.

# Sentinel™ A50

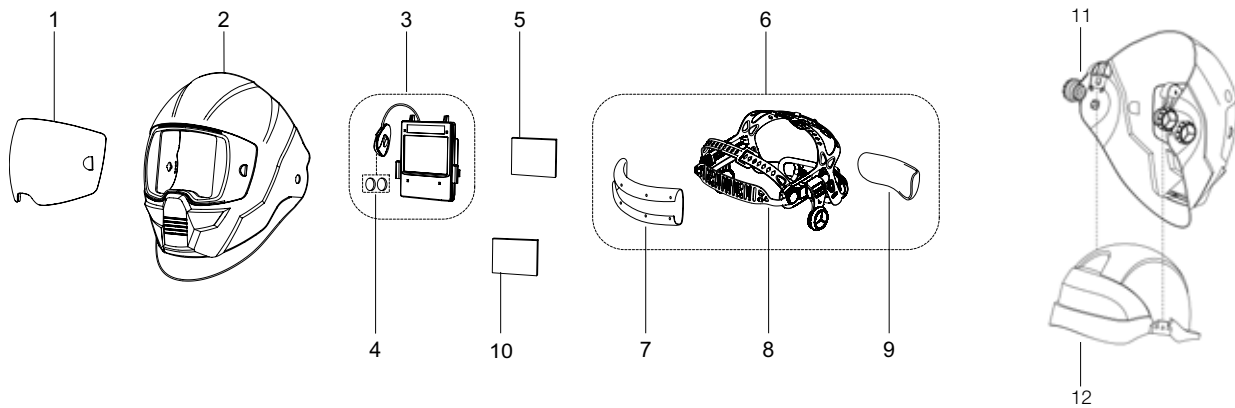

WELDING HELMETS

## Hard Hat Adapter



The Sentinel hard hat adapter is designed for use with the ESAB hard hat (0700000052). Easy to assemble - simply remove the headgear from the Sentinel A50 helmet, assemble the hard hat adapter, insert the hard adapter into the hard hat slot.

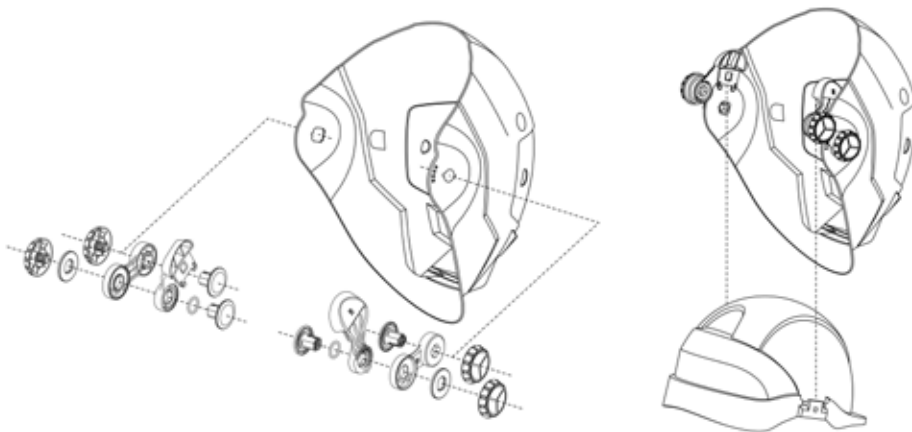

## Additional Accessories



HD Front Cover Lenses

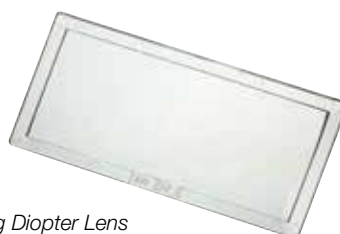

Magnifying Diopter Lens

## Warrior™ Tech

Shade 9-13 auto-darkening welding helmet



- Designed to meet the needs of welders, featuring a high-tech, lightweight shell for protection from heat, sparks, and spatter
- Large welding lens provides optimal viewing area with excellent quality using the latest auto-darkening filter (ADF) technology
- External shade adjustment between Shade 9 and Shade 13, and optical class 1/2/1/2
- Delay and sensitivity can be adjusted from the inside
- Four arc sensors for higher response and wider coverage and wa large viewing area of 3.85 x 1.88 in. (98 x 48 mm) providing a wider field of vision and increased spatial awareness
- Sensitivity control is an adaptable feature useful when welding low amperages (GTAW) for better reaction to darker arc light
- Delay control enabling the welder to set how long the lens stays dark after the welding arc stops - short delay helps get the job done faster during tack welding, whilst longer delay is useful for high amperage welding

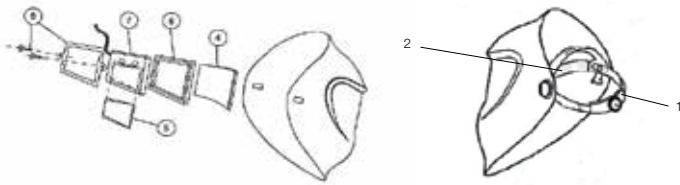

Specifications		
Viewing Area	Lens Shade	Classification
3.85 x 1.88 in. (98 x 48 mm)	Shade 9 and Shade 13	1/2/1/2

Ordering Information	
Warrior Tech 9-13 – Black	0700000400
Warrior Tech 9-13 – Yellow	0700000401

Options & Accessories		
1	ESAB Head Gear Pro with sweat band	0700000415
2	Sweat Band, pack of 2	0700000244
3	Front Cover Lens	0700000010
4	Inside Cover Lens	0700000416
5	ESAB 9-13 ADF Cradle	0700000418
6	Lens Retainer with Screws	0700000419

## Globe-Arc

Flip-front welding helmet



- Provides outstanding protection for all kinds of metal working including arc welding, grinding, gas cutting, gas welding, and plasma cutting
- Its design is unique to flip-front and grinding helmets, and is equipped with strong, comfortable headgear
- Globe-Arc's visor, along with a combination of inner and outer lenses, provides full protection against IR, UV, and visible light
- Inner lenses are available in a variety of different shades: Shade 2, Shade 3, and Shade 5
- Note that when adding the upper and lower visor shades together, the actual shade is one unit less, i.e. shade 3 main visor and shade 8 flip visor give a combined protection at shade 10

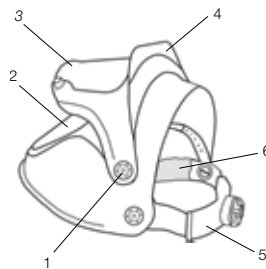

Ordering Information	
Globe-Arc Shade 10	0700000947
Globe-Arc Shade 11	0700000943

Options & Accessories		
1	Hinge Set	0700000267
2	Large Inner Visor Globe-Arc Clear	0700000238
2	Large Inner Visor Globe-Arc DIN 2	0700000239
2	Large Inner Visor Globe-Arc DIN 3	0700000240
2	Large Inner Visor Globe-Arc DIN 5	0700000241
3	Outer Flip Visor Globe-Arc DIN 5	0700000242
3	Outer Flip Visor Globe-Arc DIN 8	0700000247
3	Outer Flip Visor Globe-Arc DIN 10	0700000248
4	Flip-Up Globe-Arc Holder	0700000249
5	Head Gear Globe-Arc	0700000243
6	Sweat Band	0700000244

ESAB's FR line of flame retardant clothing is designed to give maximum protection to the professional welder while providing comfort in the most demanding environments. Garments are made with Phoenix FR material, which gives the clothing 100% FR protection for the lifetime of the garment. There are no worries of washing out or wearing down the flame retardant fibers as these properties are an inherent part of the garment.

## FR Jersey

- Lightweight
- For warmer climates



Ordering Information	
Size Medium	0700010374
Size Large	0700010375
Size X-Large	0700010376
Size XX-Large	0700010377

## FR Fleece

- Full zip front
- For cooler climates



Ordering Information	
Size Medium	0700010369
Size Large	0700010370
Size X-Large	0700010371
Size XX-Large	0700010372

PROTECTIVE CLOTHING

## FR Winter

- Rugged
- For the coldest climates



Ordering Information	
Size Medium	0700010359
Size Large	0700010360
Size X-Large	0700010361
Size XX-Large	0700010362



## Proban Welding Jacket



- Designed for maximum comfort and safety
- Sleeves and shoulders are made of durable grade-A leather to withstand the exposure to welding spatter
- The front and back are made from flame-retardant Proban material
- The jacket features concealed inner pockets, adjustable sleeves, a stand-up collar, and Kevlar® stitching

### Ordering Information

Size Large	0700010302
Size X-Large	0700010303
Size XX-Large	0700010304

## Shop Coat



- This knee-length, comfortable shop coat is styled to fit the way you work, with two lower front pockets plus breast pocket
- Features simple snap-front closure and side slits for easy access to trouser pockets

### Ordering Information

Size Medium	781F58
Size Large	781F59
Size X-Large	781F60
Size XX-Large	781F61

## Welding Apron



- This protective apron distributes weight effectively
- Kevlar® stitched and 42.1 in. long

### Ordering Information

One Size	0700010007
----------	------------



All ESAB gloves have a high resistance to heat and offer additional protection against spatter.

 Tested against mechanical stress such as abrasion, cut, tear, and puncture.

 Tested for thermal performance, such as exposure to an open flame, contact heat, convective heat, radiant heat, and small and large splashes of molten metal.

## Curved MIG (GMAW) Gloves



- These gloves offer a whole new approach to fit, form, and function
- Ergonomically designed to fit the natural curve of the hand, these MIG gloves are made from heavy and fine-cut leather, and are lined from hand to cuff
- With the curved design, the glove fits the hand perfectly, and also has a flexible wrist area that reduces friction
- With welted seams, Kevlar® stitching, and reinforced thumb, these gloves are ultra strong and offer the highest level of protection

Ordering Information	
Size Large	0700005043
Size X-Large	0700005040

## Heavy-Duty Black Gloves



- A welding glove made of black, strong cow-grain leather
- High dexterity with Kevlar® stitching ensures that the glove can resist hard mechanical stress
- The gloves are also fully welted

Ordering Information	
One Size	0467222007

## Heavy-Duty Aluminized Gloves



- A welding glove with two layers of cowhide capable of withstanding extreme heat – suitable for tubular wire welding
- The facing of aluminum-coated PFR rayon reflects 95% of the thermal radiation
- Gloves are padded with COMFOflex®, and sewn with fourfold Kevlar®
- The thumb is angled for high comfort

Ordering Information	
One Size	0700 005 010

GLOVES

## Curved TIG (GTAW) Gloves



- These TIG gloves are ergonomically designed to fit the natural curve of the hand, giving you quality and comfort like none other
- Made from thin, high-quality leather with improved fit for higher dexterity, the gloves are highly durable, with welted seams and Kevlar® stitching
- Extremely lightweight for additional comfort

### Ordering Information

Size Large	0700005041
Size X-Large	0700005042

## Professional TIG (GTAW) Gloves



- A quality GTAW glove with a reinforced thumb and 5.1 in.-long leather cuff
- The palm is fully lined for increased comfort and protection

### Ordering Information

One Size	0701415963
----------	------------



## Safety Glasses



- Weld Warrior safety glasses are used for drilling, chipping, and metalworking
- They have a sporty style, are soft to the touch, and have a lightweight wrap-around neck cord
- The glasses are extremely flexible and durable, and are available in four different lens configurations that protect against UV radiation
- Plus, all eyewear meets ANSI Z87.1 standards

### Ordering Information

Clear	0700012030
Smoked	0700012031
Amber	0700012032
Shade 5	0700012033



Clear



Smoked



Amber



Shade 5

## Goggles



- A one-piece goggle with a soft molded body, indirect ventilation, and a 4 x 1.75 in. lens aperture
- The goggle is fitted with a Shade 5 filter, and will fit over prescription glasses

### Ordering Information

Goggle Shade 5	17862
----------------	-------

## Proban Hood

- Flame-resistant head protection that covers the head, neck, and shoulders



### Ordering Information

Proban Hood	0000593269
-------------	------------

## Hard Hat

- The lightest, strongest, and most comfortable helmet available
- Manufactured from ABS material, and weighs less than a pound
- Head gear is equipped with a ratchet adjustment for easy adjustment and comfort



### Ordering Information

Hard Hat Yellow	0700000052
-----------------	------------

## Welder's Cap

- Cap to be worn under helmet to protect your head and hair



### Ordering Information

Size Medium	781F97
Size Large	781F98

## Insulated Helmet Liner

- The insulated helmet liner is worn underneath the welding helmet to offer protection when working in a cold environment



### Ordering Information

Insulated Helmet Liner	0000904378
------------------------	------------

## Leather Helmet Pad

- Made of top-grain cowhide with foam cushion and rust-resistant hardware to provide ultimate protection and comfort



### Ordering Information

Leather Helmet Pad	747F92
--------------------	--------

## Easy-Lite

- Easily attaches to your welding helmet, hard hat, safety glasses, or anywhere that additional light is required and an excellent tool for adapting to a stainless steel inspection mirror
- Battery has over 50 hours of life.



### Ordering Information

Easy-Lite	0700014040
-----------	------------



# 100% SATISFACTION IS OUR **PROMISE TO YOU.**

**Our pledge:** To create the best products and give customers complete buying confidence with our 100% Satisfaction Guarantee and the most extensive warranties, including a new lifetime warranty on all Victor® EDGE™ Series 2.0 regulators.



Learn more at [esab.com/ironclad](http://esab.com/ironclad).



ESAB / [esab.com](http://esab.com)



GEN-27001 / NA / English / 03-12-19 / Note: Specifications subject to change without notice. Products may vary from those pictured.